



APE Single Acting Diesel Impact Hammer

THE WORLD'S LARGEST PILEDRIVERS

Model D16-52

SPECIFICATIONS

| | |
|---|---------------------------|
| Stroke at Maximum Rated Energy | 135 in (343 cm) |
| Maximum Rated Energy (Setting 4) | 39,690 ft-lbs (53.81 kNm) |
| (Setting 3) | 32,943 ft-lbs (44.66 kNm) |
| (Setting 2) | 26,195 ft-lbs (35.51 kNm) |
| Minimum Rated Energy (Setting 1) | 19,448 ft-lbs (26.37 kNm) |
| <i>(VARIABLE THROTTLE ALLOWS FOR INFINITE FUEL SETTING)</i> | |
| Maximum Obtainable Stroke | 150 in (381 cm) |
| Maximum Obtainable Energy | 44,100 ft-lbs (59.79 kNm) |
| Speed (Blows Per Minute) | 34-52 |

WEIGHTS (APPROXIMATE)

| | |
|--|--|
| Piston | 3,528 lbs (1,600 kg) |
| Anvil | 749 lbs (340 kg) |
| Anvil Cross Sectional Area | 124.42 in ² (802.71 cm ²) |
| Hammer Weight (Includes Trip Device) | 8,000 lbs (3,629 kg) |
| Typical Operating (Weight With DB26 & H-Beam insert) | 10,772 lbs (4,886 kg) |

CAPACITIES

| | |
|--|----------------------|
| Fuel Tank (Runs on Diesel or Bio-Diesel) | 8.3 Gal (31 Liters) |
| Oil Tank | 2.3 Gal (8.7 Liters) |

CONSUMPTION

| | |
|----------------------|---|
| Diesel or Bio-Diesel | 1.9 Gal/hr (7 Liters/hr) |
| Oil Tank | 0.13 Gal/hr (.49 Liters/hr) |
| Grease | 8 to 10 Pumps Every 20 Minutes of Operation Time. |

STRIKER PLATE FOR DB26

| | |
|-----------|---|
| Weight | 628 lbs (284 kg) |
| Diameter | 22.5 in (57.15 cm) |
| Area | 398 in ² (2,567.74 cm ²) |
| Thickness | 6 in (15.24 cm) |

STRIKER PLATE FOR DB20

| | |
|-----------|---|
| Weight | 440 lbs (199 kg) |
| Diameter | 17.75 in (45 cm) |
| Area | 247 in ² (1,593.55 cm ²) |
| Thickness | 6 in (15.24 cm) |

CUSHION MATERIAL

| | |
|-----------------------|---------------------|
| Type | Monocast MC 904 |
| Diameter-DB26 | 22.5 in (57.15 cm) |
| Diameter-DB20 | 17.75 in (45.08 cm) |
| Thickness | 2 in (5.08 cm) |
| Elastic-Modulus | 285 ksi (1,965 mpa) |
| Coeff. of Restitution | 0.8 |

DRIVE CAP

| | |
|--------|--------------------|
| DB 26: | 1,076 lbs (488 kg) |
| DB 20: | 750 lbs (340 kg) |

INSERT WEIGHT

| | |
|--|--------------------|
| H-Beam Insert for 12" (305mm) and 14" (355 mm): | 948 lbs (430 kg) |
| Large Pipe Insert for the Sizes 12" to 24" Diameter: | 1,830 lbs (830 kg) |

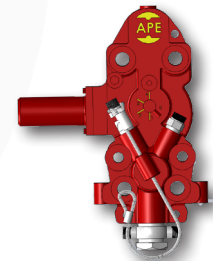
MINIMUM LEADER SIZE/OPERATING LENGTH

| | |
|-------------------------------------|------------------------------------|
| Minimum Box Leader Size | 8 in x 21 in (20.32 cm x 53.34 cm) |
| Operating Length as Described Above | 348 in (883.92 cm) |

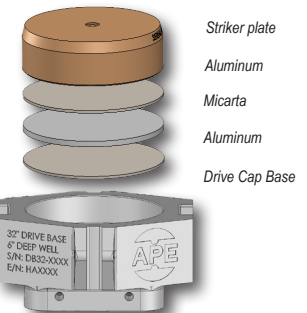


Image may not represent actual Model

Optional Variable Throttle Control



Drive Base Assembly



Specifications may vary due to site conditions, specific hammer conditions or product set up.

Specifications may change without notice.

Consult the factory for details on any specific product (800) 248-8498.

Copyright © 2022 American Piledriving Equipment Inc. All Rights Reserved



WWW.AMERICANPILEDIVING.COM

Ape@americanpilediving.com