



MODEL 815  
VIBRATORY  
DRIVER/EXTRACTOR

OPERATING AND MAINTENANCE MANUAL

# ICE MODEL 815

VIBRATORY PILE DRIVER/EXTRACTOR

WITH MODEL 570D POWER PACK

Serial Numbers: 174135 & Above

OM-815/570-1092



**INTERNATIONAL  
CONSTRUCTION  
EQUIPMENT, INC.**

SPECIALIZING IN PILE DRIVING EQUIPMENT

CORPORATE OFFICES: 301 WAREHOUSE DR., MATTHEWS, N.C. 28105

PHONES 800 438-9281 & 704 821-7681 TELEX 572385



**MODEL 815  
VIBRATORY  
DRIVER/EXTRACTOR**

**PREFACE**

This manual was prepared to acquaint the owner, operator and serviceman with the operation and maintenance of the vibratory driver/extractor. We suggest that this manual be carefully studied before operating or undertaking any maintenance work on the unit.

This manual is organized into two major categories

The first category is for routine OPERATING INSTRUCTIONS of the unit and includes a GENERAL DESCRIPTION section, which presents a basic explanation of the driver/extractor and some of its specifications. The MAINTENANCE AND ADJUSTMENT section should be referred to periodically for normal servicing of equipment. All machines and equipment require systematic, periodic inspection and maintenance, if they are to perform satisfactorily, over a long period of time. The driver/extractor is primarily a vibrating machine and if not given the best of care, or if improperly used and maintained, it is self-destructive. Therefore, the unit should receive at least the same care and maintenance as other high quality construction equipment.

The second category is for parts reordering and it includes both a PARTS LIST and a pictorial drawing of the assembly, for easier determination of the required part. Refer to the ORDERING PARTS section of the PARTS LIST for more specific procedures regarding parts ordering. Adherence of the listed procedures will insure receipt of the required part(s) with the minimal amount of delay or error.



**MODEL 815  
VIBRATORY  
DRIVER/EXTRACTOR**

**WARRANTY**

**INTERNATIONAL CONSTRUCTION EQUIPMENT STANDARD WARRANTY**

International Construction Equipment (ICE) warrants new products sold by it to be free from defects in material or workmanship for a period of 90 days after date of delivery to the first user and subject to the following conditions:

ICE's obligation and liability under this WARRANTY is expressly limited to repairing or replacing, at ICE's option, any parts which appear to ICE, upon inspection, to have been defective in material or workmanship. Such parts shall be provided at no cost to the user, at the business establishment of ICE or the authorized ICE distributor of the product, during regular working hours. This WARRANTY shall not apply to component parts or accessories of products not manufactured by ICE and which may carry the warranty of the manufacturer thereof, or to normal maintenance (such as engine tune-up) or to normal maintenance parts (such as oil filters). Replacement or repair parts installed in the product covered by this WARRANTY are warranted only for the remainder of the warranty, as if such parts were original components of said product. ICE COMPANY MAKES NO OTHER WARRANTY, EXPRESS OR IMPLIED, AND MAKES NO WARRANTY OF MERCHANTABILITY OF FITNESS, FOR ANY PARTICULAR PURPOSE.

ICE's obligation under this WARRANTY shall not include any transportation charges, cost of installation, duty, taxes or any other charges whatsoever, or any liability for direct, indirect, incidental, or consequential damage of delay. If requested by ICE, products or parts for which a warranty claim is made are to be returned, transportation prepaid to ICE. Any improper use, including operation after discovery of defective or worn parts, operation beyond rated capacity, substitution of parts not approved by ICE or any alteration or repair by others in such manner as in ICE's judgement affects the product materially and adversely, shall void this WARRANTY.

NO EMPLOYEE OR REPRESENTATIVE IS AUTHORIZED TO CHANGE THIS WARRANTY IN ANY WAY OR GRANT ANY OTHER WARRANTY UNLESS SUCH CHANGE IS MADE IN WRITING AND SIGNED BY AN OFFICER OF ICE.



**MODEL 815  
VIBRATORY  
DRIVER/EXTRACTOR**

**TABLE OF CONTENTS**  
**OPERATING INSTRUCTIONS**

<b>I.</b>	<b><u>GENERAL</u></b>	<b>PAGE</b>
	A. General	I- 1
	B. Vibrator	I- 2
	C. Hydraulic Clamp Head	I- 2
	D. Power Unit	I- 2
	E. Remote-Control Pendant	I- 3
	F. Specification	I- 3
<b>II.</b>	<b><u>PREPARATION FOR OPERATING</u></b>	
	A. General	II- 1
	B. Safety Precautions	II- 1
	C. Rigging of Vibrator	II- 2
	D. Connection of Hydraulic Clamp	II- 2
	E. Connection of Hydraulic Hoses	II- 3
	F. Bleeding Hydraulic Clamp Hoses	II- 5
	G. Filling Vibrator Pressure Hose	II- 5
<b>III.</b>	<b><u>OPERATING INSTRUCTIONS</u></b>	
	- . Control Panel with Remote Control Pendant	III- 1
	A. Completion of Set-Up and Maintenance	III- 2
	B. Control Panel	III- 2
	C. Starting and Warming Up Engine	III- 4
	D. Warming Hydraulic Fluid	III- 4
	E. Operation of Remote-Control Pendant	III- 5
	F. Changing Frequency	III- 6
	G. Shutdown	III- 7
<b>IV.</b>	<b><u>MAINTENANCE AND ADJUSTMENTS</u></b>	
	A. General	IV- 1
	B. Daily	IV- 1
	C. 125 Hours (Service Meter Units)	IV- 3
	D. 250, 500 Hours and Other	IV- 3
	E. Annually	IV- 3
	F. Severe Conditions	IV- 3
	G. Lubrication	IV- 4
	H. Draining and Filling Hydraulic Fluid Reservoir	IV- 8
	I. Changing Hydraulic Return Filter Elements	IV- 9
	J. Changing Vibrator Hydraulic Filter Element	IV-10
	K. Bolt Torque Information	IV-11



**MODEL 815  
VIBRATORY  
DRIVER/EXTRACTOR**

**TABLE OF CONTENTS**

**OPERATING INSTRUCTIONS (CONTINUED)**

<b>V.</b>	<b><u>HYDRAULIC CIRCUITRY</u></b>	<b><u>PAGE</u></b>
	A. Hydraulic Clamp	V- 1
	B. Vibrator Drive Motor	V- 1
	C. Other	V- 3
	D. Hydraulic Schematic	V- 4
	E. Hydraulic Components List	V- 5
<b>VI.</b>	<b><u>ELECTRICAL CIRCUITY</u></b>	
	- . Electrical Schematic	VI- 1
	A. Starting Diesel Engine	VI- 2
	B. Stopping Diesel Engine	VI- 2
	C. Safety Control System	VI- 2
	D. Closing Hydraulic Clamp	VI- 3
	E. Opening Hydraulic Clamp	VI- 3
	F. Starting Vibrator	VI- 4
	G. Stopping Vibrator	VI- 4
	H. Other	VI- 4
	I. Electrical Components List	VI- 5
	J. Electrical Layout	VI- 6

**PARTS LIST**

<b>VII.</b>	<b><u>GENERAL DATA</u></b>	
	A. Abbreviations	VII- 1
	B. Screws and Bolts	VII- 1
	C. Serial Number Locations	VII- 2
<b>VIII.</b>	<b><u>ORDERING PARTS</u></b>	
	A. Procedure	VIII- 1
	B. Fitting Description Key	VIII- 2
	Fitting Style Selector Chart - SC1	VIII- 3
	C. Hose Description Code	VIII- 4
	D. Parts Identification	VIII- 5
	Parts Lists and Drawings	VIII-6 to VIII-47
	E. Miscellaneous Accessories	VIII-48 to VIII-50
	F. Recommended Spare Parts	VIII-51 to VIII-53
	G. CYL. Install. Instruct. and Asm. Procedures	VIII-54
	H. Recommended Tightening Torque	VIII-55



**MODEL 815  
VIBRATORY  
DRIVER/EXTRACTOR**

# OPERATING INSTRUCTIONS

## I. GENERAL DESCRIPTION

### A. GENERAL

The ICE Model 815 is a variable-frequency vibratory pile driver/extractor designed to drive and extract sheet, pipe, timber and concrete piles, caisson pipe and H, I and wide-flange beams.

The Model 815 operates in a frequency range of 800 to 1600 vibrations per minute to provide maximum pile penetration rates in a wide variety of soils. The unit has an eccentric moment of 4000 inch-pounds and operates with an amplitude of 1/2 to 1 inch.

The vibratory driver unit consists of two major components. (1) The vibrator with attached clamp and (2) the power unit with remote control pendant.

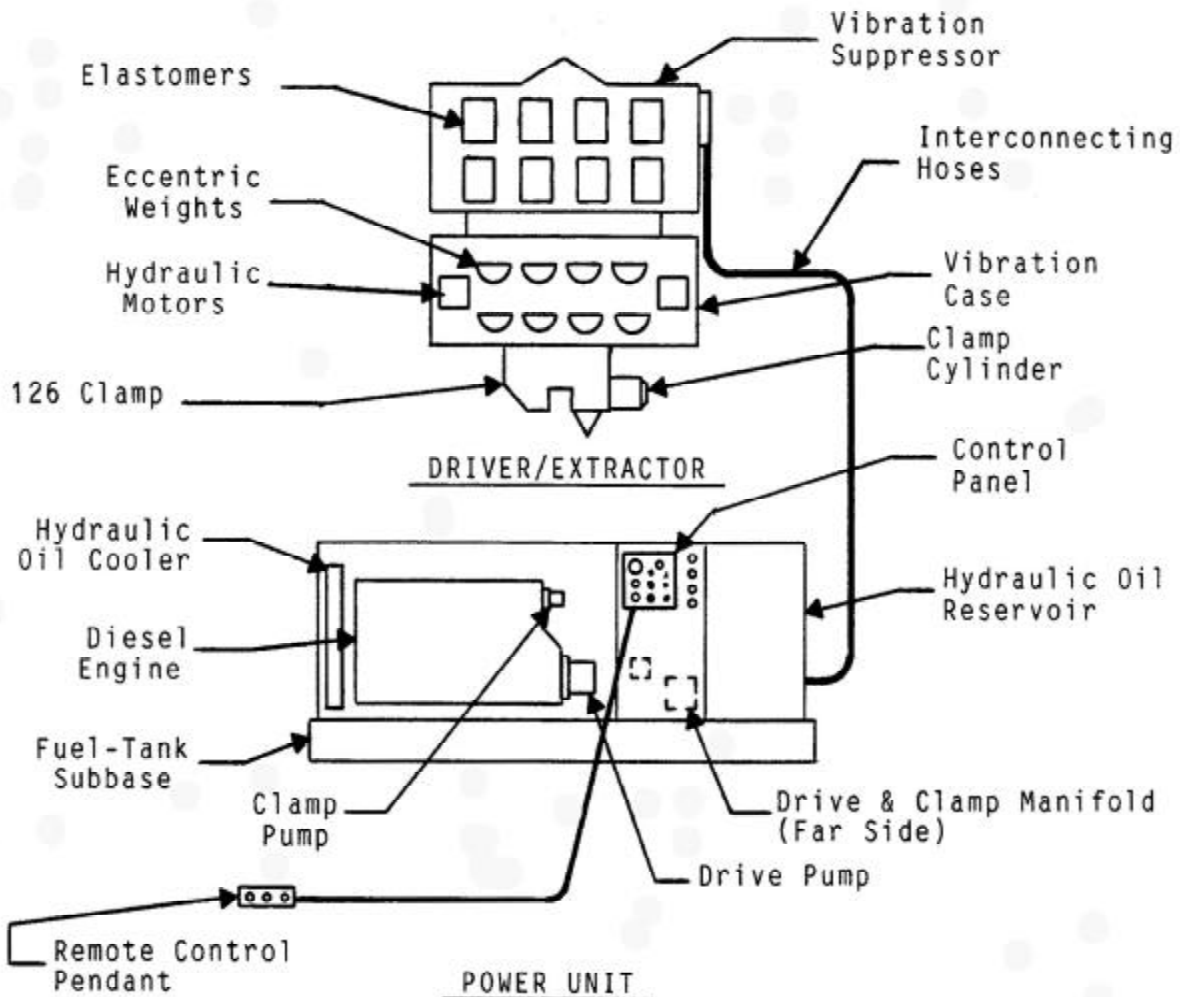



MODEL 815  
VIBRATORY  
DRIVER/EXTRACTOR

# OPERATING INSTRUCTIONS

I. GENERAL DESCRIPTION

B. VIBRATOR

The vibrator consists of two major components. (1) The vibration case and (2) the vibration suppressor.

The vibration case contains eight eccentric weights which rotate in a vertical plane to create vibration. The eccentric weights are driven by two hydraulic motors mounted on the vibration case. The two motors and eight eccentrics are all gear connected to maintain proper synchronization. The eccentric and motor shafts are mounted in heavy-duty cylindrical roller bearings. Lubrication is provided by a splash system activated by the rotating eccentrics and gears.

The vibration suppressor contains eight rubber elastomers to isolate the vibration case from the crane line. The suppressor is designed for a maximum line pull of 40 tons during extraction.

C. HYDRAULIC CLAMP

Three types of hydraulic clamps are available for the Model 815 vibrator. The Model 126 universal clamp head will drive and extract most types of sheet piling, 14" H-beams, and wide flange beams. The Model 127 Z-pile clamp is designed especially for single Z-sheets. It will also handle Z-pile doubles. The Model 80 caisson clamps are used in pairs with either the 7-foot or 11-foot caisson beam to drive and extract pipe from 15" ID to 132" OD.

D. POWER UNIT

The Model 815 vibrator is powered by the ICE Model 570 power pack. The 570 power pack is powered by a Caterpillar 3408TA diesel engine. The engine develops 503 HP at 2100 RPM.

The totally enclosed power unit is mounted on a skid-type fuel tank sub-base. A Control panel at the side of the unit contains all operating gauges and controls. A common reservoir supplies hydraulic fluid to two separate hydraulic pumps - one for the vibrator motors and one for the hydraulic clamp.

Three hydraulic hoses, 150 feet in length, connect the power unit to the hydraulic motors on the vibrator. Two other hydraulic hoses run from the power unit to the hydraulic clamp.



**MODEL 815  
VIBRATORY  
DRIVER/EXTRACTOR**

# OPERATING INSTRUCTIONS

I. GENERAL DESCRIPTION

E. REMOTE-CONTROL PENDANT

The vibrator is operated by a hand-held remote control pendant. The pendant has two, two-way switches and an indicator light. One switch (VIBRATOR SWITCH) starts and stops vibration. The other switch (CLAMP SWITCH) closes and opens the hydraulic clamp. The light indicates that adequate clamping pressure exists for vibration to begin. Note: Controls are duplicated on the control panel in case the pendant is damaged. (See pg. III-6, Section E-e)

F. SPECIFICATIONS

1. Constant improvement and engineering progress make it necessary that we reserve the right to make specification changes without notice.

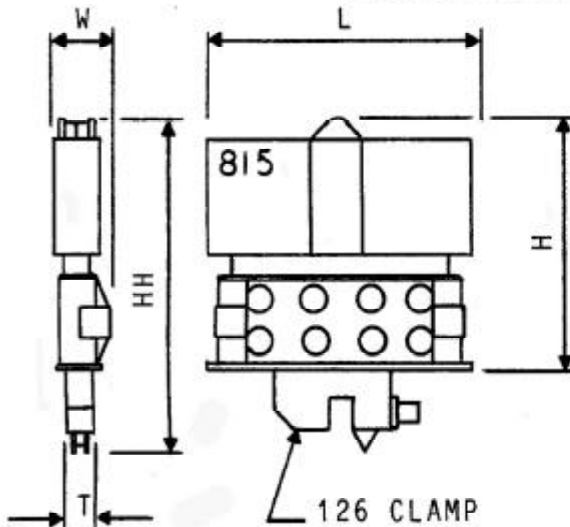

2. MODEL 815 VIBRATOR (with hydraulic clamp)

Type.....	Hydraulic
Eccentric Moment....	4000 In-lbs.
Frequency.....	800-1600 VPM
Amplitude.....	1/2"-1"
Pile Clamping Force....	120 Tons
Max. Line Pull for	
Extraction.....	40 Tons
Suspended Weight with 126	
Clamp.....	16,700 lbs.
Length [L].....	.96 in.
Width [W].....	.28 in.
Throat Width [T].....	.12 in.
Height with Clamp [HH]...	.122 in.
Height without clamp [H]..	.095 in.

3. MODEL 570 POWER UNIT

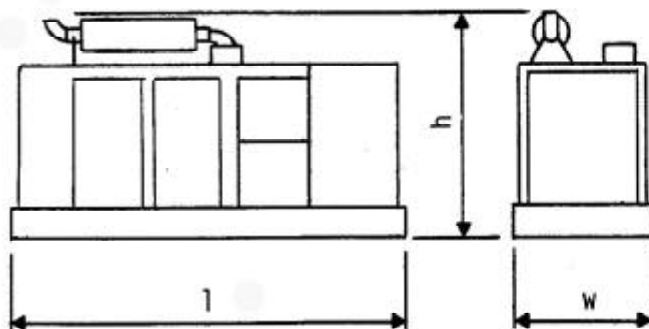

Type.....	Diesel
Engine.....	CAT 3408TA
Horsepower (2100 RPM).....	503
Weight.....	14900 lbs.
Length [l].....	154 in.
Width [w].....	.60 in.
Height [h].....	.90 in.





MODEL 815  
VIBRATORY  
DRIVER/EXTRACTOR

# OPERATING INSTRUCTIONS

## II. PREPARATION FOR OPERATION

### A. GENERAL

When unloading and unpacking the vibratory driver, use extreme care. For your protection, make a thorough inspection of the unit immediately on delivery. In case of any damage or shortage, notify the transit agent at once and have the delivering carrier make a notation on the freight bill.

### B. SAFETY PRECAUTIONS

Safety is basically common sense. There are standard safety rules, but each situation has its own peculiarities which can not always be covered by rules. Therefore, your experience and common sense will be your best guide to safety. Be ever watchful for safety hazards and correct deficiencies promptly.

Use the following safety precautions as a general guide to safe operations:

1. When operating in a closed area, pipe exhaust fumes outside. Continued breathing of exhaust fumes may be fatal.
2. When servicing batteries, do not smoke or use an open flame in the vicinity. Batteries generate explosive gas during charging. There must be proper ventilation when charging batteries.
3. When filling fuel tank, do not smoke or use open flame in the vicinity.
4. Be extremely careful when using a carbon tetrachloride fire extinguisher in a closed area as it produces toxic vapor. Provide adequate ventilation before entering a closed area where carbon tetrachloride has been used.
5. Never adjust or repair the unit while it is in operation.



MODEL 815  
VIBRATORY  
DRIVER/EXTRACTOR

# OPERATING INSTRUCTIONS

## II. PREPARATION FOR OPERATION

### B. SAFETY PRECAUTIONS (CONTINUED)

6. Never operate the diesel engine with the governor linkage disconnected to control the fuel rack.
7. Remove all tools and electrical cords before starting.
8. Store oily rags in containers.
9. Never store flammable liquids near the engine.

REMEMBER, SAFETY IS EVERYONE'S BUSINESS.

### C. RIGGING OF VIBRATOR

A steel wire rope sling must be connected to the lifting pin of the vibration suppressor. The required strength of this sling depends on the capacity of the crane and the work to be carried out. A safety factor of five is recommended. Several turns of a smaller diameter cable will usually last longer than one turn of a larger diameter cable.

### D. CONNECTION OF HYDRAULIC CLAMP

The vibrator is usually shipped with the hydraulic clamp already attached.

If the clamp is not attached, it will be necessary to attach it to the bottom of the vibrator. Orient the clamp to the vibrator with the clamp cylinder end (movable jaw) at the same end of the vibrator at which the hose chute is mounted. All eight (1.5-6UN x 5.00) bolts must be in place and torqued to approximately 2800 ft.lbs. To do this place a pipe over the end of the Allen wrench to provide a six-foot lever arm. Have two men tighten each bolt.

For caisson work, the caisson beam must be attached to the bottom of the vibrator and tightened as above. Then slide the clamps into position on the caisson beam.



MODEL 815  
VIBRATORY  
DRIVER/EXTRACTOR

# OPERATING INSTRUCTIONS

## II. PREPARATION FOR OPERATION

### E. CONNECTION OF HYDRAULIC HOSES

#### 1. Connection of hoses at power unit.

- a. The vibrator and hydraulic clamp are connected to the power unit by five hydraulic hoses (Fig. 1).

CAUTION: The power unit must be shut down during connection of the hydraulic hoses.

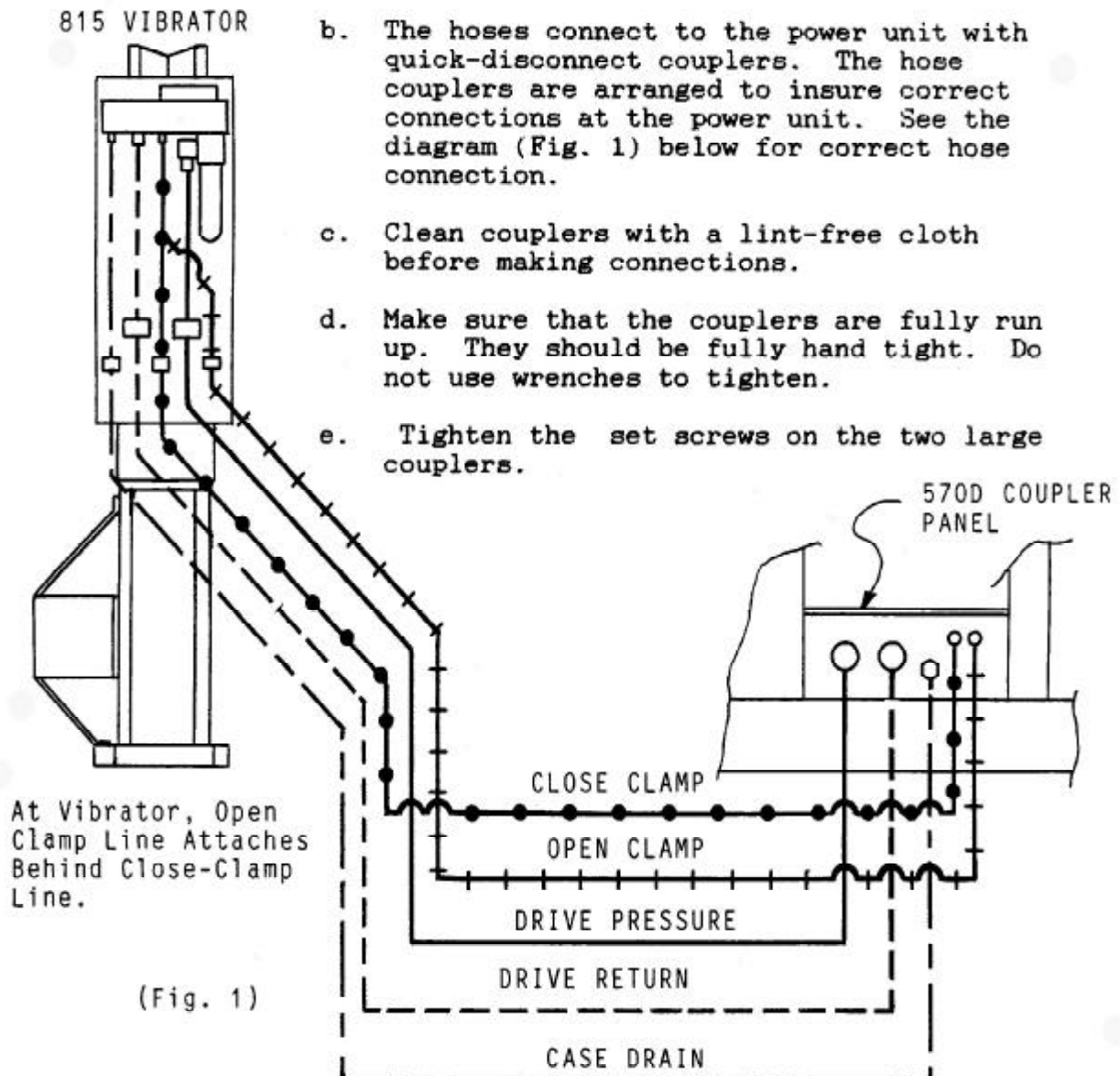



MODEL 815  
VIBRATORY  
DRIVER/EXTRACTOR

# OPERATING INSTRUCTIONS

## II. PREPARATION FOR OPERATION

### E. CONNECTION OF HYDRAULIC HOSES (CONTINUED)

#### 2. Connection of hoses at vibrator.

- a. The vibrator is usually shipped with the hoses attached to the vibrator. If the hoses have been shipped separately, they must be connected in the field. Fig. 1 on the previous page shows the correct arrangement of the five hoses connecting the power unit to the vibrator.

**CAUTION:** Starting the vibrator with the hoses reversed will result in low power or possible ruptured hoses.

- b. The vibrator is usually shipped with the hydraulic clamp and hoses attached. If the clamp has been shipped separately, the two hoses connecting the clamp to the vibrator must be connected. Fig. 2 shows the correct arrangement of these hoses. For caisson clamps, four hoses must be connected. The two connections on the opposite end of the vibrator are reversed from the positions shown on the drawing below. The clamp connections are the same.

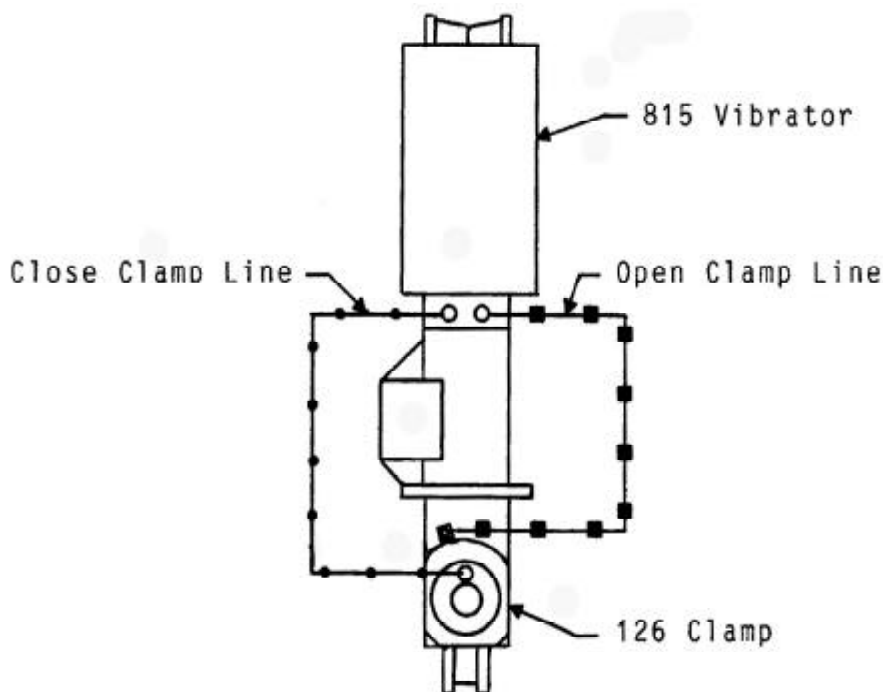

(Fig. 2)



MODEL 815  
VIBRATORY  
DRIVER/EXTRACTOR

# OPERATING INSTRUCTIONS

## II. PREPARATION FOR OPERATION

### F. BLEEDING HYDRAULIC CLAMP HOSES

1. When the vibrator and hydraulic clamp are shipped with all hoses attached (between vibrator and clamp and five main hoses connected to the vibrator), the hoses are usually full of fluid and may be used immediately. However, if any of the clamp hoses are connected at the jobsite or if air is present in hoses, they must be bled prior to operation.
2. Read SECTION III - OPERATING INSTRUCTIONS.
3. Start and warm up the diesel engine in accordance with SECTION III-C - STARTING AND WARMING UP ENGINE.
4. With the engine warmed-up and running at 1200 RPM, loosen the close-clamp line at the hydraulic clamp. Turn the clamp switch on the remote-control pendant to CLOSE. Wait until fluid flows from the connection at the hydraulic clamp. When fluid flows without air, tighten the connection.
5. After the line has been bled, alternately turn the clamp switch to CLOSE and OPEN to insure that the clamp is working properly. It may be necessary to bleed the line more than once. The open-clamp line may also require bleeding.

### G. FILLING VIBRATOR PRESSURE HOSE

1. The vibrator is usually shipped with the vibrator hydraulic hoses full of fluid and the unit may be used immediately. However, if the pressure hose has been removed from the vibrator, the hose should be allowed to fill with hydraulic fluid prior to full speed operation.
2. Read SECTION III - OPERATING INSTRUCTIONS.
3. Start and warm up the diesel engine in accordance with SECTION III-C - STARTING AND WARMING UP ENGINE.
4. With the engine warmed up and running at 1800 RPM, the pressure hose will fill with hydraulic fluid in about ten minutes. Wait ten minutes for this to occur. Do not press the START button on the control pendant.



MODEL 815  
VIBRATORY  
DRIVER/EXTRACTOR

# OPERATING INSTRUCTIONS

## III. OPERATING INSTRUCTIONS

### CONTROL PANEL WITH REMOTE CONTROL-PENDANT

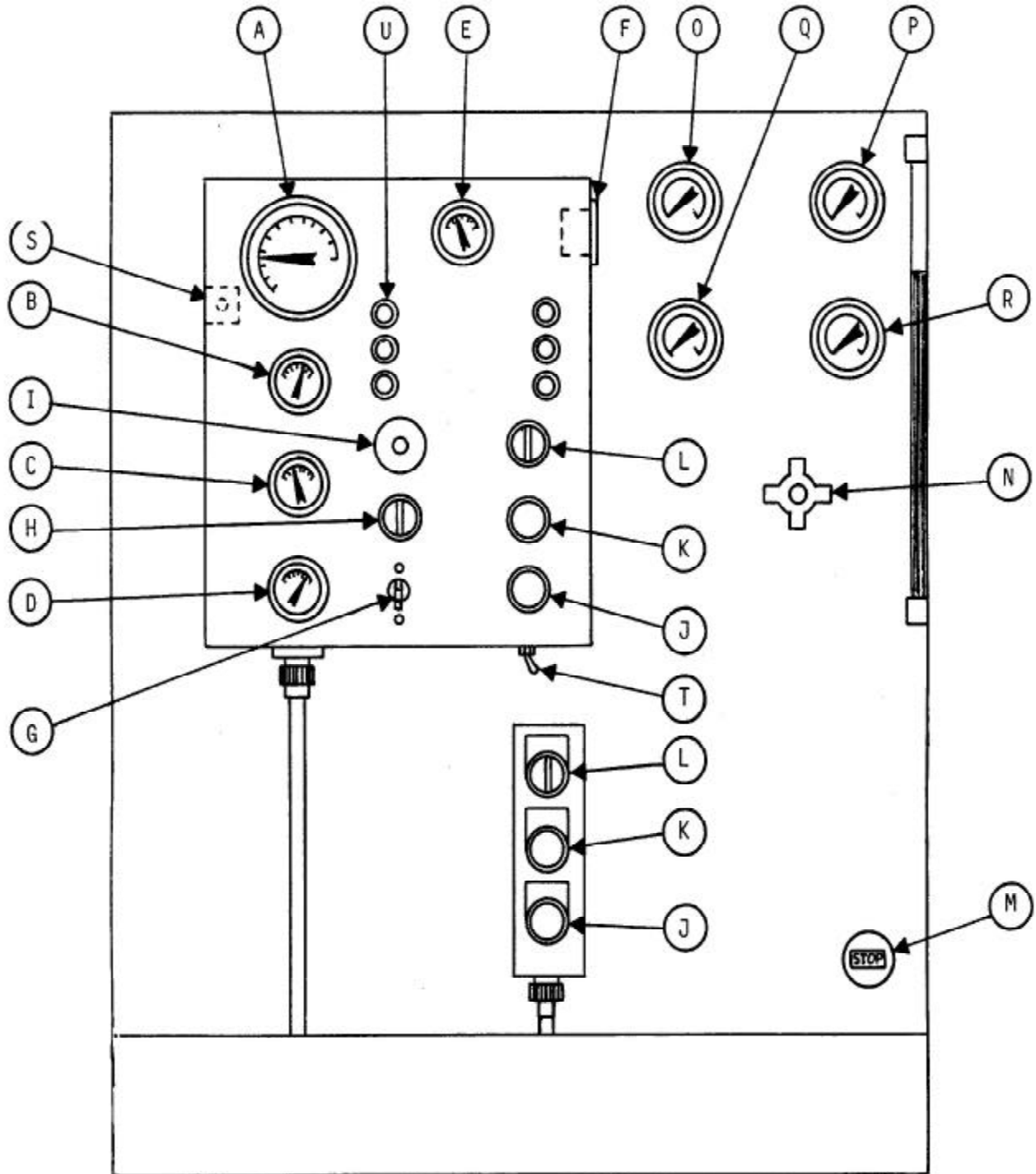



MODEL 815  
VIBRATORY  
DRIVER/EXTRACTOR

# OPERATING INSTRUCTIONS

## III. OPERATING INSTRUCTIONS

### A. COMPLETION OF SET-UP AND MAINTENANCE

1. Complete all preparation as described in Section II.
2. Read Section IV - MAINTENANCE AND ADJUSTMENTS and perform any required maintenance.

### B. CONTROL PANEL

1. The control box (Fig. 1, page III-1) at the side of the power pack contains the controls and gages for the diesel engine, vibrator, and the OPERATION AND MAINTENANCE INSTRUCTIONS.
2. Control panel contains the following controls, gages and shutdown indicators.
  - a. Engine Tachometer
  - b. Engine oil Pressure Switch Gage
  - c. Engine Water Switch Gage
  - d. Engine Ammeter
  - e. Hydraulic Fluid Temperature Switch Gage
  - f. Engine Hour Meter
  - g. Main Power Switch - ON-OFF Switch & Cir. Breaker
  - h. Engine - ON-OFF-START - Switch for Diesel Engine
  - i. Engine Shutdown Reset Button - over ride button for engine shutdown switch. Must be held in until oil pressure exceeds 30 PSI.
  - j. Vibrator Stop Button
  - k. Vibrator Start Button - with clamp light.
  - l. Clamp Switch - open - close.
  - m. Emergency Stop - pull out to stop engine.
  - n. Engine Throttle
  - o. Pressure Gage - Forward
  - p. Pressure Gage - Reverse
  - q. Pressure Gage - Close Clamp
  - r. Pressure Gage - Open Clamp
  - s. Vibrator - Auger Switch
  - t. Remote - Local Switch
  - u. Shutdown indicator lights (6)
    1. Engine Oil Pressure shutdown indicator - comes on if engine has been shut down automatically due to engine oil pressure being low.
    2. Engine Water Temperature shutdown - comes on if engine has been shutdown automatically due to engine water overheating.
    3. Engine Overspeed shutdown indicator - comes on if engine has been shut down automatically due to the engine being run at excessively high RPM'S.



MODEL 815  
VIBRATORY  
DRIVER/EXTRACTOR

# OPERATING INSTRUCTIONS

## III. OPERATING INSTRUCTIONS

### B. CONTROL PANEL (CONTINUED)

4. Filter Clogged shutdown indicator - comes on if engine has been shut down automatically due to the hydraulic fluid return filter being clogged.
  5. Hydraulic Fluid Level Low shutdown indicator comes on if engine has been shut down automatically due to low hydraulic fluid level in the reservoir.
  6. Hydraulic Fluid Temperature High shutdown indicator - comes on if engine has been shut down automatically due to high hydraulic fluid temperature.
3. The Operating & Maintenance Instructions on the control box door are there as reminders only. They are not complete and not intended to substitute for a thorough understanding of the Operators Manual.





MODEL 815  
VIBRATORY  
DRIVER/EXTRACTOR

# OPERATING INSTRUCTIONS

## III. OPERATING INSTRUCTIONS

### C. STARTING AND WARMING UP ENGINE

1. Before starting the engine, read the CATERPILLAR OPERATION GUIDE carefully. Follow the engine starting, operating and maintenance procedures in that manual.
2. The diesel engine should not be started if the temperature of the hydraulic fluid is below 0 deg F. If ambient temperatures below 0 deg. F are anticipated, an immersion heater for the hydraulic fluid is available. Consult ICE for details.
3. Turn the MAIN POWER switch on the control panel to on.
4. Pull out the ENGINE THROTTLE about half way. Pressing the button on the end of the throttle allows rapid throttle adjustment. Turning the throttle allows fine adjustment. BE sure the EMERGENCY STOP knob is fully pushed in.
5. Turn the ENGINE START switch to START. Press and hold the SHUTDOWN RESET in until engine oil pressure exceeds 30 PSI.
6. Adjust the throttle until the engine is running at 1500 RPM and allow to warm up five minutes. After the engine is warmed up, adjust throttle so engine runs at 2300 RPM's under no load. The engine should hold 2100 RPM's under load.
7. Allow the temperature of the hydraulic fluid to come up to at least 30 deg. before starting the vibrator.

### D. WARMING HYDRAULIC FLUID

1. The vibrator should not be operated at full speed if the temperature of the hydraulic fluid is below 60 deg. F. The HYDRAULIC FLUID COLD light on the control panel will be on if fluid temperature is below 60 deg. F.
2. If temperature is below 60 deg. F, set the engine at 1500 RPM and press the START button on the control pendant to start the vibrator. Allow the vibrator to run until the temperature of the hydraulic fluid exceeds 60 deg. F.



MODEL 815  
VIBRATORY  
DRIVER/EXTRACTOR

# OPERATING INSTRUCTIONS

## III. OPERATING INSTRUCTIONS

### D. WARMING HYDRAULIC FLUID (CONTINUED)

3. When the engine is warmed up and hydraulic fluid temperature is at least 60 deg. F, full speed operation may begin.
4. The hydraulic fluid temperature is maintained within acceptable limits by the Hydraulic Temperature Fluid Switch Gage. Fluid temperature should never exceed 160 deg.F. The engine will automatically shut down if fluid temperature exceeds 160 deg. F.

CAUTION: Do not operate the vibrator if hydraulic fluid temperature exceeds 160 deg. F as this may damage hydraulic components.

### E. OPERATION OF REMOTE-CONTROL PENDANT

1. The operation of the vibratory driver is controlled by the remote-control pendant. The pendant is connected to the control cabinet with 50 feet of electrical cable to permit operation from any advantageous position near the vibrator.
2. The pendant has two control buttons, a two way switch, and an indicator light.

#### a. To Clamp to Pile:

Position vibratory driver on pile. Turn the clamp switch on the pendant to CLOSE. The CLAMP light (Start Button) on the pendant will come on when the hydraulic clamp has achieved adequate pressure to permit vibration to begin. The light should normally come on in a few seconds.

#### b. To Start Vibration:

Press the START button (lighted).

CAUTION: Do not press the START button until the CLAMP light comes on, indicating adequate clamping pressure.



MODEL 815  
VIBRATORY  
DRIVER/EXTRACTOR

# OPERATING INSTRUCTIONS

## III. OPERATING INSTRUCTIONS

### E. OPERATION OF REMOTE-CONTROL PENDANT (CONTINUED)

#### c. To Stop Vibration:

Press the STOP button.  
The vibrator will stop vibration in a few seconds.  
If the STOP button does not stop the vibrator, turn  
the MAIN POWER switch on the control panel to OFF.

#### d. To unclamp from pile.

Turn the CLAMP switch to OPEN to release the  
hydraulic clamp so that the vibrator can be removed  
from the pile. Hold the CLAMP switch in the OPEN  
position for approximately 10 seconds or until a  
visual check shows the jaws to be fully open.

CAUTION: Do not turn the switch to OPEN until  
a visual check indicates that vibration  
has stopped.

- #### e. If the remote control pendant is damaged or the pendant line is cut, you may still operate the vibrator by using the control switches on the control panel. (See Fig. 1 on page III-1 items J, K, L). To activate these switches, find the toggle switch on the bottom of the control panel, labeled "REMOTE-LOCAL". Turn the switch to LOCAL and the switches on the control panel will be functional, and the remote control pendant will be disabled.

### F. CHANGING FREQUENCY

1. In order to provide maximum flexibility in achieving  
optimum pile penetration and extraction rates, the  
frequency of the vibratory driver is adjustable.
2. The frequency can be varied from 600 to 1600  
vibrations per minute by changing engine speed.  
Engine speed is changed with the ENGINE THROTTLE on  
the control panel. Vibration frequency corresponds  
to engine speed according to the table shown on page  
III-7.



MODEL 815  
VIBRATORY  
DRIVER/EXTRACTOR

# OPERATING INSTRUCTIONS

## III. OPERATING INSTRUCTIONS

### F. CHANGING FREQUENCY (CONTINUED)

<u>ENGINE RPM</u>	<u>VIBRATOR VPM</u>
2300	1600
2010	1400
1730	1200
1440	1000
1150	800

### G. SHUT DOWN

1. Stop the vibrator.
2. Allow the diesel engine to run for five minutes at 1100 RPM.
3. Reduce speed to low idle for about thirty seconds.
4. Check engine crankcase oil level while engine is idling.
5. Stop the engine by turning the ENGINE START switch to OFF.
6. Turn MAIN POWER switch to OFF.
7. CAUTION: If the diesel engine is shut down while the vibrator is clamped to a pile, the clamp check valve will keep the vibrator clamped to the pile. However, system leakage could result in a loss of clamp pressure. Therefore, it is not recommended to leave the vibrator clamped to a pile when the diesel engine is not running.



MODEL 815  
VIBRATORY  
DRIVER/EXTRACTOR

# OPERATING INSTRUCTIONS

## IV. MAINTENANCE AND ADJUSTMENTS

### A. GENERAL

Preventive maintenance includes normal servicing that will keep the vibratory driver, clamp, and power unit in peak operating condition and prevent unnecessary trouble from developing. This servicing consists of periodic lubrication and inspection of the moving parts and accessories of the unit.

Lubrication is an essential part of protective maintenance, controlling to a great extent the useful life of the unit. Different lubricants are needed and some components in the unit require more frequent lubrication than others. Therefore, it is important that the instructions regarding types of lubricants and frequency of their applications be closely followed.

To prevent minor irregularities from developing into serious conditions that might involve shut-down and major repair, several other services or inspections are recommended for the same intervals as the periodic lubrications. The purpose of these services or inspections is to assure the uninterrupted operation of the unit.

Thoroughly clean all lubrication fittings, caps, filler and level plugs and their surrounding surfaces before servicing. Prevent dirt from entering with lubricants and coolants. The intervals given in the schedule are based on normal operation. Perform these services, inspections, etc., more often as needed for operation under abnormal or severe conditions.

### B. DAILY

1. Check the entire unit prior to and during set-up each day or at the beginning of each shift.
2. Prior to starting the power unit or at the beginning of each shift, check the following items:
  - a. Visibly inspect all bolts, nuts and screws including the bolts fastening the hydraulic clamp to the vibration case to insure they are tight. **IMPORTANT:** vibration loosens bolts check carefully.



MODEL 815  
VIBRATORY  
DRIVER/EXTRACTOR

# OPERATING INSTRUCTIONS

## IV. MAINTENANCE AND ADJUSTMENTS

### B. DAILY (CONTINUED)

- b. Tighten bolts holding gripping jaws in hydraulic clamp.
- c. Grease plunger in hydraulic clamp with any good multi-purpose grease.
- d. Check the oil level in the vibration case and add oil if required. The oil level should be in the middle of the sight glass. Change oil if milky or black.
- e. Check the fluid level in the hydraulic reservoir and refill if necessary.

**CAUTION:** It is absolutely imperative that no dirt or other impurities be permitted to contaminate the hydraulic fluid. Any contamination will drastically shorten the life of the high-pressure hydraulic system.

- f. Visually check all hoses for signs of damage or cuts that might cause hose failure during operation. Be sure all connections are tight, especially the quick-disconnect couplers.
  - g. Visually inspect all suppressor elastomers.
  - h. Electrical components need no maintenance except periodic wiping with a clean, dry, lint-free cloth to remove dust.
  - i. Perform all daily (10 Service Meter Units) maintenance checks and lubrication in the CATERPILLAR OPERATION GUIDE. For the ICE Model 570 power unit, the HOUR METER on the control panel may be considered to read Caterpillar's "Service Meter Units".
3. After engine start-up, check the following:
- a. Check all hydraulic hoses for leaks. Make sure they hang freely with no kinks.
  - b. Check both pumps and all hydraulic manifolds for leaks.
  - c. Check the filter indicators. The filter on the vibrator may be checked at any time. The return filters on the power unit must be checked with the diesel engine running at full speed.



MODEL 815  
VIBRATORY  
DRIVER/EXTRACTOR

# OPERATING INSTRUCTIONS

## IV. MAINTENANCE AND ADJUSTMENTS

### C. 125 HOURS (125 Service Meter Units)

1. Drain and refill the vibration case.
2. Perform all maintenance checks and lubrication indicated in the Caterpillar OPERATION GUIDE.

### D. 250, 500 HOURS and Other

1. See Caterpillar OPERATION GUIDE.
2. After the first 500 hours, drain and replace the lubricant in the multi-pump drive, there after change every six months.

### E. ANNUALLY

1. Have the hydraulic fluid tested by a local hydraulic service center. Replace if required.
2. See Caterpillar OPERATION GUIDE.

### F. SEVERE CONDITIONS

1. The service intervals specified are based on normal operating conditions. Operation under unusual conditions require some adjustments in servicing intervals.
2. When the average temperature is above 80 deg. F or below -10 deg. F, reduce service intervals to one-half of those specified in Sections C through E.
3. When operating in the presence of dust or sand, reduce service time intervals by one-half of those specified.
4. When operating in excess of twelve hours per day, reduce service time intervals by one-half of those specified.
5. When operating in air with high salt or moisture, the servicing intervals need not usually be changed. However, the unit should be inspected weekly to determine if additional servicing be required. Also, have hydraulic fluid tested quarterly.



MODEL 815  
VIBRATORY  
DRIVER/EXTRACTOR

# OPERATING INSTRUCTIONS

## IV. MAINTENANCE AND ADJUSTMENTS

### F. SEVERE CONDITIONS (CONTINUED)

6. During stand-by or inactive period, the servicing intervals may be twice those specified above. The unit should be exercised every week. also, refer to the Caterpillar OPERATION GUIDE.

### G. LUBRICATION

#### 1. Crankcase (Diesel Engine)

- a. Follow the engine manufacturer's maintenance schedule and the lubricating oil specifications outlined in the CATERPILLAR OPERATION GUIDE.
- b. The lubricant shall meet the performance requirements of API Service Classifications CD or MIL-L-2104C.
- c. New engines are shipped with ASHLAND 400M+HDT 15W-40 but the following multi-grade crankcase oils are recommended for use or replacement in normal operation (10 deg. F to 90 deg. F) (-12 deg. C to 32 deg. C).

AMOCO	- 15W-40	300
ARCO	- 15W-40	Fleet S3 Plus
BORON (BP)	- 15W-40	Vanellus C Extra
CHEVRON	- 15W-40	Delo 400
CITGO	- 15W-40	C500 Plus
CONOCO	- 15W-40	Fleet Supreme
EXXON	- 15W-40	XD3
GULF	- 15W-40	Super Duty Plus
MOBIL	- 15W-40	Delvac Super
PHILLIPS	- 15W-40	Super HD II
SHELL	- 15W-40	Rotella T
SUN	- 15W-40	Sunfleet Super C
TEXACO	- 15W-40	Ursa Super Plus
UNION	- 15W-40	Guardol
VALVOLINE	- 15W-40	All Fleet

- d. For operation in extreme sub-zero climate, refer to the CATERPILLAR OPERATION GUIDE Crankcase Lubricating Oils or contact the nearest Caterpillar representative.





MODEL 815  
VIBRATORY  
DRIVER/EXTRACTOR

# OPERATING INSTRUCTIONS

## IV. MAINTENANCE AND ADJUSTMENTS

### G. LUBRICATION (CONTINUED)

#### 2. Vibration Case

The fluid level is easily read through the sight glass located at the lower center of the vibration case opposite the motor side. Lubricating oil may be added when necessary, through either of the holes in the vibration case top plate after removing the 1" pipe plugs. To drain the case, remove a 3/4" pipe plug at either end of the base plate. Tilt the case for complete drainage.

#### 3. Multi-Pump Drive Adapter

The fluid level is easily checked by removing the 1/4 hex head pipe plug on the right side of the multi-pump drive adapter. Lubricating oil should be to this level. If low, lubricating oil may be added by removing the 1/2 socket head pipe plug located on the left side of the Multi-pump Drive Adapter. Draining the lubricating oil may be done by removing the 1/2 socket head pipe plug on the bottom of the Multi-pump Drive Adapter.

4. The preferred lubricating oil for ICE vibration cases and multi-pump drive adapters is a synthetic oil (Mobil SHC 634). Due to their purity, synthetics can provide longer service life in heavily loaded, severe conditions. They also provide good oxidation stability in high operating temperatures. Longer intervals between fluid changes and fewer maintenance hours spent on mechanical service can generally be realized with synthetics.

Therefore, whenever the "first preferred" oil is not available or desired and an alternate (natural petroleum base) fluid is selected, it will be necessary to test and/or change the oil at shorter intervals.

The vibration case and multi-pump drive adapter lubricant installed at the factory is MOBIL SHC-643 (a synthetic), any of the following gear lubes may be used when changing lubricants:



MODEL 815  
VIBRATORY  
DRIVER/EXTRACTOR

# OPERATING INSTRUCTIONS

## IV. MAINTENANCE AND ADJUSTMENTS

### G. LUBRICATION (CONTINUED)

FIRST Preference Group (Synthetic):  
MOBIL SHC-634

SECOND Preference Group (Natural Petroleum Base):

BORON	Gearep 140
CHEVRON	Gear Comp. NL460
CITGO	Premium MP 85W-140
CITGO	Standard MP 85W-140
GULF	Lub 85W-140 Lub 85W-140
PHILLIPS	SMP 85W-140
SHELL	Omala 460 Omala 460
SUN	Sunep 1110

THIRD Preference Group (Natural Petroleum Base):

AMOCO	Perma Gear EP140
ARCO	Pennant NL 460
CONOCO	EP 460
EXXON	Spartan EP 460
PHILLIPS	AP 140
TEXACO	Meropa 460
UNION	MP 85W-140
VALVOLINE	Gear Lub 85W-140

MOBIL SHC-634 Lubricant is available from ICE in five gallon cans. See SECTION VIII - ORDERING PARTS, page VIII-52

### 5. Hydraulic System

To maintain the maximum operating efficiency in the precision parts of the hydraulic system, it is extremely important to eliminate factors which can cause breakdowns or unsatisfactory performance in the system. Among the most common of these factors are rust, corrosion, contamination and products of oil deterioration. Most problems can be minimized or avoided simply by maintaining a disciplined preventive maintenance program.

Some simple steps to follow as part of that program are:

- a. Keep stored oil dry and clean at all times and always store in clean containers.
- b. Always clean tools, spouts, lids, funnels, etc. when used in conjunction with the transfer of oil.



MODEL 815  
VIBRATORY  
DRIVER/EXTRACTOR

# OPERATING INSTRUCTIONS

## IV. MAINTENANCE AND ADJUSTMENTS

### G. LUBRICATION (CONTINUED)

- c. Never put dirty oil into the hydraulic system. Use only clean, uncontaminated oil of the types recommended below. Never return to the system any fluid which has leaked out.

NOTE: Foreign material in the hydraulic system can drastically effect the life and operation of many hydraulic component parts.

- d. Clean or replace filter elements at the first indication that they are dirty or ineffective.

Mixing of different manufacturers' hydraulic fluid is not recommended. However, it can be done if the fluids are miscible (contain the same base and additive). It may be necessary to contact an oil supplier to determine this.

New power units are shipped with SUN 2105 hydraulic oil. The following recommended fluids may be used when replacing fluid in the hydraulic system.

#### FIRST Preference Group:

MOBIL	DTE-15
SUN	2105

#### SECOND Preference Group:

AMOCO	Rykon MV
ARCO	Duro AW32
CHEVRON	Hydraulic AW32
PHILLIPS	Magnus A32
SHELL	Tellus 32

#### THIRD Preference Group:

BORON	Energol HLP32
CITGO	All-Temp HD
CONOCO	Super 32
EXXON	Nuto H32
GULF	Harmony 32AW
SUN	Sunvis 805 MG
TEXACO	Rando HD AZ32
UNION	Unax AW32



MODEL 815  
VIBRATORY  
DRIVER/EXTRACTOR

# OPERATING INSTRUCTIONS

## IV. MAINTENANCE AND ADJUSTMENTS

### G. LUBRICATION (CONTINUED)

Whenever fluids from the second preference group are used, it is necessary to test the oil more often to insure that viscosity remains within recommended limits while in service. Using fluids from the third preference group requires even a more discerning inspection than use of fluids from the second group. Third Group oils may be used when temperature variations are less than those listed below.

The recommended fluids were chosen based on the hydraulic system operating temperature range being 5 deg. F (-15 deg. C) (cold [ambient] start-up to 160 deg. F (71 deg. C) (maximum operating).

When operating in arctic conditions, it is recommended to use an immersion heater to pre-heat the oil prior to starting. Contact ICE for other arctic operating procedures. It may also be necessary in extremely cold or hot climates to use a different viscosity oil which is better adapted to adverse conditions. Contact the nearest oil supply representative for suggested procedures.

SUN-2105 hydraulic fluid is available from ICE in five gallon cans. See SECTION VIII - ORDERING PARTS, page VIII-52.

### H. DRAINING AND FILLING HYDRAULIC FLUID RESERVOIR

1. The Hydraulic reservoir is draining by removing a plug on the bottom of the reservoir.
2. The hydraulic reservoir is filled by the manual pump mounted on the back (engine side) of the reservoir. All fluid is pumped to the reservoir through the returned filter (F2) to insure no dirt enters the hydraulic system.



MODEL 815  
VIBRATORY  
DRIVER/EXTRACTOR

# OPERATING INSTRUCTIONS

## IV. MAINTENANCE AND ADJUSTMENTS

### I. CHANGING HYDRAULIC RETURN FILTER ELEMENT

1. The return filters are located in the hydraulic reservoir below the Control Panel.
2. To remove elements, remove the two hex nuts and carriage bolts from the clamp halves. Remove clamp halves and cover plug. (Note: Approximately one gallon of hydraulic fluid will be lost.)
3. Remove the bypass valve and spring assembly from filter housing. Remove and separate the two elements. Save the plastic element connector.
4. Clean filter housing interior and all component parts with a lint-free rag.
5. Check Clamp seal for damage. Lubricate with multi-purpose grease.
6. Install two new elements on filter connector, slide element assembly into housing. Be sure inner most element engages tube in back of housing
7. Replaced bypass valve and spring assembly.

CAUTION: Failure to install support springs could result in element collapse with subsequent damage to oil cooler and/or filter housing.

8. Replace cover plug and clamp halves, tighten two nuts.
9. Repeat for second filter.



MODEL 815  
VIBRATORY  
DRIVER/EXTRACTOR

# OPERATING INSTRUCTIONS

## IV. MAINTENANCE AND ADJUSTMENTS

### J. CHANGING VIBRATOR HYDRAULIC FILTER ELEMENT

1. The vibrator filter is located behind the hose guard at the end of the vibration suppressor.
2. Remove the two screws at the bottom of the hose guard and rotate the guard upward to expose the filter.
3. Unscrew the filter can. It should be firmly hand tight.
4. Remove the old filter element and insert the new element.
5. Remove the O-ring and check it for cuts and nicks. Replace if damaged. Lubricate with multi-purpose grease.
6. Screw in the filter can with the new element until it is firmly hand tight.
7. Reset dirt indicator button.
8. Replace hose guard.



MODEL 815  
VIBRATORY  
DRIVER/EXTRACTOR

# OPERATING INSTRUCTIONS

## IV. MAINTENANCE AND ADJUSTMENTS

### K. BOLT TORQUE INFORMATION

Torque, in foot-pounds, is determined by the length of the wrench handle (in feet) multiplied by the weight (or force in pounds) applied at the end of the handle. For example, if the wrench is one foot long and five pounds of force is applied at the end of the handle, the total torque applied would be five foot pounds. A six inch wrench would require ten pounds of force to obtain five foot pounds of torque.

Proper use of the torque wrench is important. To obtain the listed torques, a steady pull should be exerted to the handle until the desired torque is reached.

The following torque specifications apply to the bolts from the component assemblies listed. Whenever any of these bolts, are replaced, the given torque specifications should be adhered to.

#### VIBRATION SUPPRESSOR Page VIII-7 & 9

Item 14, 45	1/2"-13	119 Ft/Lbs
Item 16, 21	5/8"-11	233 Ft/Lbs
Item 6, 17, 20	3/4"-10	417 Ft/Lbs

#### VIBRATION CASE Page VIII-11

Item 24	7/16"-14	85 Ft/Lbs
Item 4, 12	1/2"-13	119 Ft/Lbs
Item 16	5/8"-11	233 Ft/Lbs

#### CLAMP BODY Page VIII-36

Item 18	1-1/2"-6	2800 Ft/Lbs
---------	----------	-------------



MODEL 815  
VIBRATORY  
DRIVER/EXTRACTOR

# OPERATING INSTRUCTIONS

## V. HYDRAULIC CIRCUITRY (REFERENCE:HYDRAULIC SCHEMATIC PG V-4)

### A. HYDRAULIC CLAMP

With the diesel engine running, hydraulic fluid is taken from the reservoir by the clamp pump (P2). The clamp pump flow returns to the reservoir if the clamp switch on the pendant has not been moved.

Turning the clamp switch on the control pendant to CLOSE activates the CLAMP CONTROL VALVE (V1). Hydraulic fluid is directed to the CLOSE CLAMP side of the hydraulic CYLINDER (CYL) in the hydraulic clamp. The clamp closes. Clamping pressure is indicated by the Clamp Pressure Gage (GA-3). When clamping pressure reaches approximately 4500 PSI, the CLAMP PRESSURE SWITCH (PS-1) deactivates the CLAMP CONTROL VALVE (V1), which directs the flow from the clamp pump to the reservoir. Pressure at the clamp is maintained by the CLAMP CHECK VALVE (CV5). If clamping pressure falls below 4200 PSI, the CLAMP PRESSURE SWITCH activates the CLAMP CONTROL VALVE to restore pressure.

Turning the clamp switch on the control pendant to OPEN activates the CLAMP CONTROL VALVE (V1). Hydraulic fluid is directed to the OPEN CLAMP side of the hydraulic cylinder. The pressure in the OPEN CLAMP line opens the CLAMP CHECK VALVE (CV5). The clamp opens. Pressure in the OPEN CLAMP line is indicated by the clamp pressure gage (GA-4).

Pressure in the clamping circuit is limited to 4800 PSI by the CLAMP RELIEF VALVE (RV2). The quick-disconnect couplers (QD3 & QD4) permit de-coupling of the clamp hoses at the power unit.

### B. VIBRATOR DRIVE

With the diesel engine running, hydraulic fluid is taken from the reservoir by the DRIVE PUMPS (P1). Fluid pressure opens the cartridges CA1, CB1 and vents the hydraulic fluid back to the reservoir through the RETURN FILTER (F2), if the vibrator button has not been pushed.

Pushing the START button, on the control pendant, activates the FORWARD SOLENOID on the CONTROL VALVE (V2). By blocking the pilot flow from cartridges CB1 and CB2, the CONTROL VALVE (V2) causes these cartridges to close, thus directing pump flow to the VIBRATOR MOTORS (M).





MODEL 815  
VIBRATORY  
DRIVER/EXTRACTOR

# OPERATING INSTRUCTIONS

## V. HYDRAULIC CIRCUITRY

### B. VIBRATOR DRIVE (CONTINUED)

Full motor speed is reached within a few seconds and the motor drive pressure is indicated by GAGE (GA - 1). Maximum drive pressure is limited to approximately 4800 PSI by the FORWARD RELIEF VALVE (RV1). The FORWARD RELIEF VALVE (RV1), if opened by over pressure, permits a small pilot flow from cartridges (CB1 AND CA2). This pilot flow causes cartridges (CB1 and CA2) to partially open and allows some or all of the pump flow to return to the reservoir. Flow to the motors is filtered by VIBRATOR FILTER (F3). Fluid returning from VIBRATOR MOTORS (M) open cartridge CB2 and returns to the reservoir through COOLER VALVE (V3) and RETURN FILTER (F2). Cartridge CB2 opens easily because its pilot flow is "vented" by BRAKE VALVE (RV4). BRAKE VALVE (RV4) is held open by pressure coming from the motor drive FORWARD system. Case drain fluid from the motors returns to the reservoir. Case drain pressure is limited to 50 PSI by the CASE DRAIN RELIEF VALVE (RV3).

Pushing the STOP button on the control pendant, de-energizes the CONTROL VALVE (V2) and "vents" (open) cartridges CA1, CB2, And CB1. Oil returning from the motors, during this "braking" period, re-closes cartridge CA2 by applying pressure through shuttle valve CC2. BRAKE VALVE RV4, now closed, blocks pilot flow from cartridge CB2, and causes it to apply back pressure to the motor return flow while the vibrator is stopping. The BRAKE VALVE RV4 limits back pressure to 1000 PSI. which can be monitored on PRESSURE GAGE GA-2.

Hydraulic fluid temperature is regulated by the COOLER VALVE (V3). When fluid temperature is below 100 deg. F, V3 directs the flow directly to the reservoir through FILTER (F2). When fluid temperature exceeds 100 deg. F, COOLER VALVE (V3) directs flow through the HEAT EXCHANGER (HE) before it enters the reservoir, through FILTER (F2). Excessive pressure in the HEAT EXCHANGER (HE) is prevented by CHECK VALVE (CV-2), which bypassed excess flow and limits pressure to 65 PSI.

The quick-disconnect couplers (QD1, QD2, and QD5) permit de-coupling of the drive and case drain hoses at the power unit.



MODEL 815  
VIBRATORY  
DRIVER/EXTRACTOR

# OPERATING INSTRUCTIONS

## V. HYDRAULIC CIRCUITRY

### C. OTHER

Returning fluid is filtered by the RETURN FILTER (F2). The return FILTER CHECK VALVE (CV1 and CV3) prevents fluid loss from the reservoir when the filter elements are removed.

A manual PUMP (MP) is provided to fill the hydraulic reservoir. A CHECK VALVE (CV4) prevents loss of fluid from the reservoir back through this pump.

Temperature of the fluid in the reservoir is continually sampled by the hydraulic fluid Temperature Switch Gage (TS-2), which shuts down the diesel engine if the fluid temperature exceeds 160 deg. F.

If the temperature of the hydraulic fluid is above 100 deg. F, the fluid returning from the motors is directed to the heat exchanger (HE) by the cooler valve (V3). The heat exchanger check valve (CV2) insures flow through the heat exchanger and provides relief if the exchanger would become clogged. If fluid temperature is below 100 deg. F, fluid is directed to by-pass the heat exchanger by the cooler valve.

Motor cavitation is prevented in the braking operation by the CHECK VALVE (CV6).

Extra Long ACCUMULATOR HOSE (AC) in pilot system expands as pressure increases. The additional pilot flow causes (CA2) to produce a smooth acceleration of VIBRATOR MOTOR (M).



**MODEL 815  
VIBRATORY  
DRIVER/EXTRACTOR**

**OPERATING  
INSTRUCTIONS**

**V. HYDRAULIC CIRCUITRY**

**D.-HYDRAULIC SCHEMATIC**

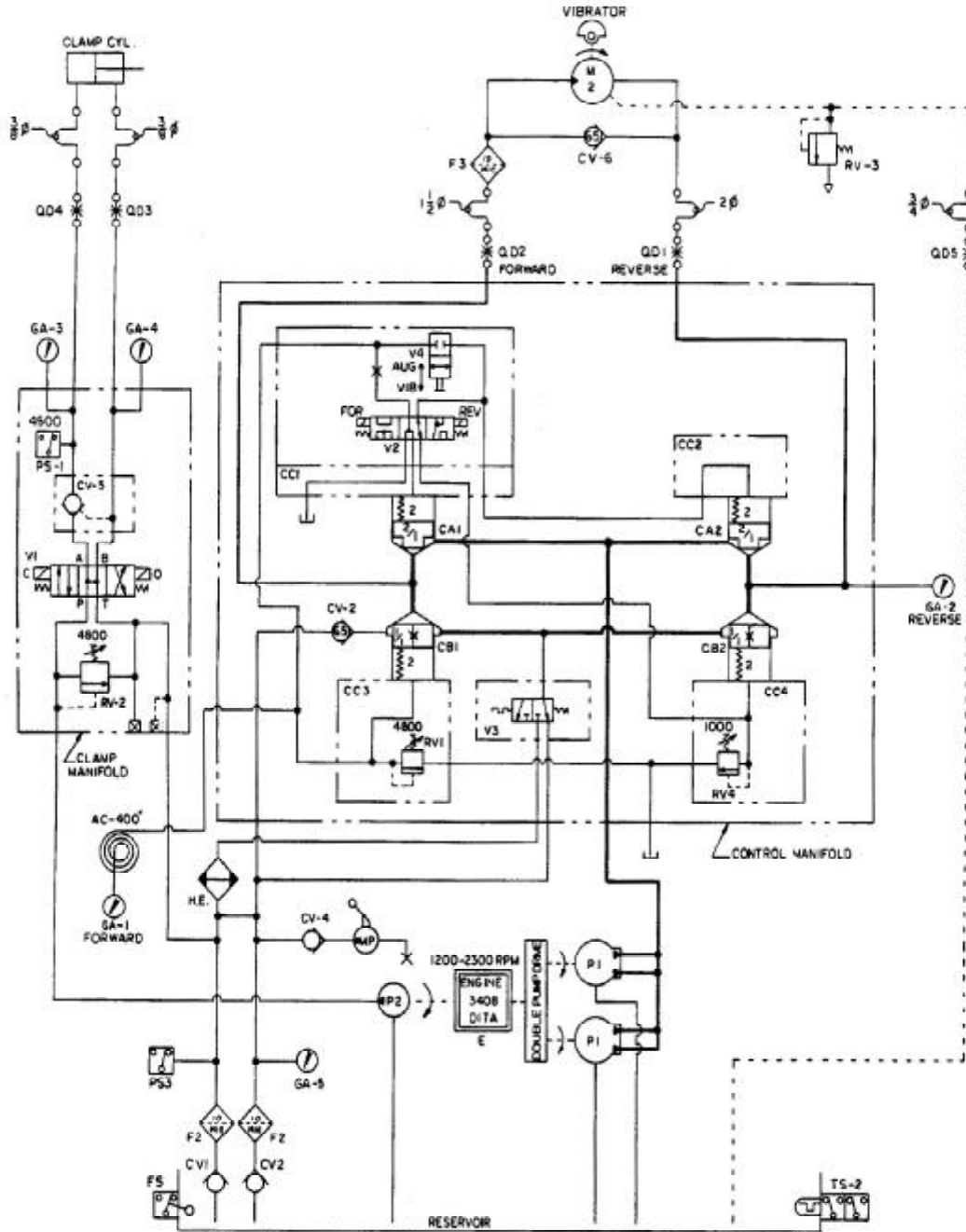



MODEL 815  
VIBRATORY  
DRIVER/EXTRACTOR

# OPERATING INSTRUCTIONS

## V. HYDRAULIC CIRCUITRY

### E. HYDRAULIC COMPONENTS LIST

<u>Notation</u>	<u>Description</u>	<u>Part Number</u>	<u>Page Ref.</u>
AC	Accumulator Hose	110680	VIII-28
CA1 & 2	Cartridge A (2)	110624	VIII-33
CB1 & 2	Cartridge B (2)	110622	VIII-33
CC1	Cartridge Cover	110610	VIII-33
CC2	Cartridge Cover	110608	VIII-33
CC3	Cartridge Cover	110606	VIII-33
CC4	Cartridge Cover	110646	VIII-33
CV2	Check Valve	130339	VIII-33
CV4	Manual Pump Check Valve	100451	VIII-25
CV5	Clamp Check Valve	110149	VIII-35
CV6	Check Valve - Vibrator	110731	VIII-9
CYL	Hydraulic Clamp Cylinder		
E	Diesel Engine	110375	VIII-24
F1	Pick-up Filter	110399	VIII-26
F2	Return Filter (2)	810481	VIII-25
	CV1&3 Return Filter Check Valve		
F3	Vibrator Filter	110281	VIII-7
FS	Float Switch	100314	VIII-25
GA-1-4	Pressure Gage	110600	VIII-28
GA-5	Filter Indicator Gage	100775	VIII-25
HE	Heat Exchange	100551	VIII-24
M	Motor (2)	110999	VIII-11
MP	Manual Pump	100447	VIII-25
NV1	Needle Valve(Auger-Vibro)	110562	VIII-33
P1	Drive Pump	110621	VIII-26
P2	Clamp Pump	110401	VIII-26
PS-1	Clamp Pressure Switch	810033	VIII-35
PS-3	Pressure Switch	100602	VIII-27
QD1	Vibrator Reverse Disconnect	110690	VIII-27
QD2	Vibrator Forward Disconnect	110692	VIII-27
QD3	Clamp Open Disconnect	100777	VIII-25
QD4	Clamp Close Disconnect	100245	VIII-25
QD5	Case Drain Disconnect	400095	VIII-25
RV1	Forward Relief Valve	110626	VIII-33
RV2	Clamp Relief Valve	100898	VIII-35
RV3	Case Drain Relief Valve	100032	VIII-7
RV4	Reverse Relief Valve	110614	VIII-33
TS-2	Temperature Switch	110640	VIII-19
VI	Clamp Control Valve	110147	VIII-35
V2	Control Valve	110618	VIII-33
V3	Cooler Valve	110628	VIII-33



MODEL 815  
VIBRATORY  
DRIVER/EXTRACTOR

# OPERATING INSTRUCTIONS

## VI. ELECTRICAL CIRCUITRY

## ELECTRICAL SCHEMATIC

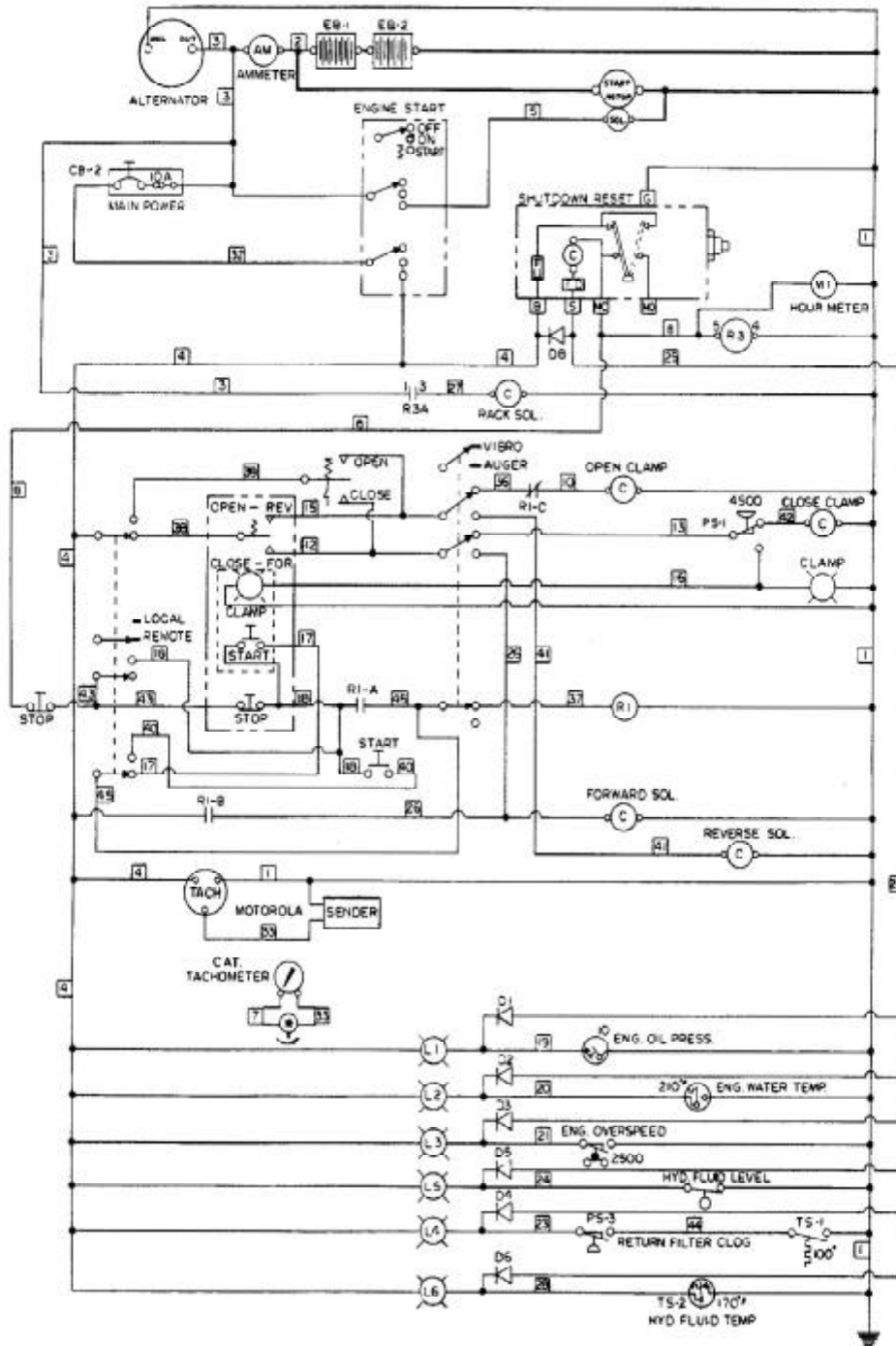



MODEL 815  
VIBRATORY  
DRIVER/EXTRACTOR

# OPERATING INSTRUCTIONS

## VI. ELECTRIC CIRCUITRY (REFERENCE: ELECTRICAL SCHEMATIC PG VI-1)

### A. STARTING DIESEL ENGINE

The engine batteries (EB1, EB2) provide 24-volt current to start the diesel engine. With the MAIN POWER (CB-2) switch on, turning the ENGINE START switch to START energizes the start motor solenoid (SOL) and turns over the diesel engine. IF fuel is available, the diesel engine will start.

### B. STOPPING DIESEL ENGINE

Turning the ENGINE START switch to OFF de-energizes the fuel pump RACK SOLENOID which shuts off the fuel supply to the diesel engine. The engine stops.

### C. SAFETY CONTROL SYSTEM

A system of safety controls shut off the fuel supply, thereby stopping the diesel engine in the event that any one of six malfunctions occur. The heart of the safety system is the SHUTDOWN RESET which is closed during normal operations (button in), thereby providing current to the fuel relay (R3). With the fuel relay energized, a set of contacts (R3A) close energizing the RACK SOLENOID and turning on the fuel supply. With the SHUTDOWN RESET closed (button in) power is provided to the vibrator start circuitry.

As mentioned above, the SHUTDOWN RESET is closed during normal operation. If the SHUTDOWN RESET is opened, the fuel relay (R3) is de-energized, contacts RA3 open, resulting in the RACK SOLENOID being de-energized thereby shutting off the fuel supply and stopping the diesel engine. The SHUTDOWN RESET opens when its timing delay coil (TD) is energized. The timing delay coil may be energized by any of the following devices.

1. Engine Oil Pressure Gage - if pressure is below 10 PSI, the contacts of the gage will be closed providing current to energize the timing delay coil (TD) and to turn on the indicator light (L1). On start-up, the button on the SHUTDOWN RESET (on the control panel) must be held in until the oil pressure exceeds 30 PSI.
2. ENGINE WATER TEMPERATURE GAGE - If water temperature exceeds 210 deg. F, the contacts of the gage will close energizing the timing delay coil (TD) and turning on the indicator light (L2).
3. Engine Overspeed Switch - if the engine overspeeds, the overspeed switch will close energizing the timing delay coil (TD) and turning on indicator light (L3).



MODEL 815  
VIBRATORY  
DRIVER/EXTRACTOR

# OPERATING INSTRUCTIONS

## VI. ELECTRICAL CIRCUITRY

### C. SAFETY CONTROL SYSTEM (CONTINUED)

4. Return Filter Switch - if the hydraulic return filter is clogged, the return filter switch (PS-3) will close energizing the timing delay coil (TD) and turning on the indicator light(L4).
5. Hydraulic Fluid Level Switch - if the hydraulic fluid level is low, the hydraulic fluid switch will close energizing the timing delay coil (TD) and turning on indicator light (L5).
6. Hydraulic Fluid Temperature Gage - if the temperature of the hydraulic fluid exceeds 160 deg. F, the hydraulic fluid temperature gage switch will close, energizing the timing delay coil (TD) and turning on indicator (L6).

A diode (D1-D6) on each malfunction switch limits the flow of direct current to prevent multiple lights coming on. Another diode (D8) prevents arcing in the malfunction switches.

### D. CLOSING HYDRAULIC CLAMP

With the diesel engine running, turning the clamp switch (OPEN-CLOSE) on the control pendant to CLOSE energizes the close-clamp solenoid (CLOSE-SOL.). This operates the clamp control hydraulic valve and closes the clamp.

When the pressure in the close-clamp hydraulic circuit reaches 4500 PSI, the pressure switch (PS-1) opens and de-energizes the close-clamp solenoid and turns on the CLAMP LIGHTS on the control pendant and control panel. If close-clamp pressure falls below 4200 PSI, the pressure switch closes and re-energizes the close-clamp solenoid to rebuild pressure. The CLAMP LIGHTS go out. When pressure returns to 4500 PSI, The pressure switch opens de-energizing the close-clamp solenoid and turns on the CLAMP LIGHTS.

### E. OPENING HYDRAULIC CLAMP

With the diesel engine running, turning the clamp switch (OPEN-CLOSE) to OPEN energizes the open-clamp solenoid (OPEN SOL.). The clamp opens.



MODEL 815  
VIBRATORY  
DRIVER/EXTRACTOR

# OPERATING INSTRUCTIONS

## VI. ELECTRICAL CIRCUITRY

### F. STARTING THE VIBRATOR

With the diesel engine running, pressing the START button on the control pendant energizes the start relay coil (R1). Start relay contacts (R1-A) close and keep the relay coil energized until the STOP button is depressed. A second set of start relay contacts (R1-B) close and energizes the FORWARD SOLENOID on the Control Valve. The Control Valve sends hydraulic fluid to the vibrator motors. The motors start. A third set of contacts (R1-C) opens to prevent the OPEN SOLENOID being energized to open the hydraulic clamp head while the vibrator is running.

### G. STOPPING THE VIBRATOR

With the diesel engine running, pressing the STOP button on the control pendant de-energizes the start relay coil (R1). The start relay contacts (R1-B) open and de-energize the FORWARD SOLENOID. The Control Valve stops the flow of hydraulic fluid to the vibrator motors. The motors stop. The start relay contacts (R1-C) close to allow the OPEN SOLENOID to be energized when the OPEN clamp button is pressed.

### H. OTHER

The ammeter (AM) indicates charging amperes. The tachometer generator (TACH GEN) powers the tachometer (TACH) to indicate engine speed. The Hour meter (M1) indicates the engine operating hours.

Duplicate vibrator and clamp switches are located on the control pendant and on the control panel. Turning the LOCAL-REMOTE switch to LOCAL activates only the clamp and vibrator switches located on the control panel. Turning the LOCAL-REMOTE switch to REMOTE only permits operation of the clamp and vibrator from the control pendant.

The 570 Power Unit may also be used to drive an ICE Auger or other Bi-directional Hydraulic Motors. By turning the VIBRO-AUGER switch to the AUGER position, the Clamp OPEN-CLOSE switch will become a FORWARD-REVERSE switch for the auger. The Vibro START and STOP buttons will be disabled.





MODEL 815  
VIBRATORY  
DRIVER/EXTRACTOR

# OPERATING INSTRUCTIONS

## VI. ELECTRICAL CIRCUITRY

### I. ELECTRICAL COMPONENTS LIST

<u>Notation</u>	<u>Reference</u>	<u>Part Number</u>	<u>Page Ref.</u>
ALTERNATOR	ALTERNATOR	See Cat.	Parts Book
AMMETER	AMMETER	110371	VIII-19
CB-2	MAIN POWER SWITCH	400141	VIII-19
CLAMP LIGHT (2)	CLAMP LIGHT	110598	VIII-19
CLOSE SOL	CLOSE-CLAMP SOLENOID	110147	VIII-35
D1-D7	DIODE	100413	VIII-19
EB-1 , EB-2	ENGINE BATTERY	100529	VIII-24
ENG. OIL PRESS.	ENGINE OIL PRESSURE GAGE AND SWITCH	100329	VIII-19
ENG. START	ENGINE START SWITCH	110615	VIII-19
ENG. WATER TEMP.	ENGINE WATER TEMPERATURE GAGE AND SWITCH	110697	VIII-19
ENG. OVERSPEED	ENGINE OVERSPEED SHUT- DOWN SWITCH	110972	VIII-27
FLUID LEVEL(FS)	HYD FLUID LEVEL SWITCH	100314	VIII-25
FOR.SOLENOID	FORWARD SOLENOID	110618	VIII-33
HOURLMETER (M1)	HOURL METER	100343	VIII-19
HYD.FLUID TEMP	HYD FLUID TEMPERATURE SWITCH GAGE	110640	VIII-19
L-1 , L-6	SHUTDOWN INDICATOR LIGHT	100355	VIII-19
OPEN/CLOSE (2)	CLAMP SWITCH (OPEN/CLOSE)	130155	VIII-19-21
OPEN SOL	OPEN-CLOSE SOLENOID	110147	VIII-35
PS-1	CLAMP PRESSURE SWITCH	810033	VIII-35
R1	MOTOR START RELAY	110584	VIII-19
R1-A,B,C	START RELAY CONTACTS	110584	VIII-19
R3	RELAY	110604	VIII-19
R3A	RACK SOL. RELAY CONTACTS	110604	VIII-19
REMOTE-LOCAL	REMOTE-LOCAL SWITCH	140361	VIII-19
RET FIL CLOG	RETURN FILTER CLOGGED SWITCH	100602	VIII-27
REVERSE SOL.	REVERSE SOLENOID	110618	VIII-33
SHUTDOWN RESET	ENGINE SAFETY SHUTDOWN	110387	VIII-19
START	VIBRATOR START BUTTON	110589	VIII-19
STOP	VIBRATOR STOP BUTTON	100363	VIII-19
TACH	TACHOMETER	110650	VIII-19
SENDER	ENGINE TACH GENERATOR	130467	VIII-27



**MODEL 815  
VIBRATORY  
DRIVER/EXTRACTOR**

# **OPERATING INSTRUCTIONS**

**VI. ELECTRICAL CIRCUITRY**

**J. ELECTRICAL LAYOUT**

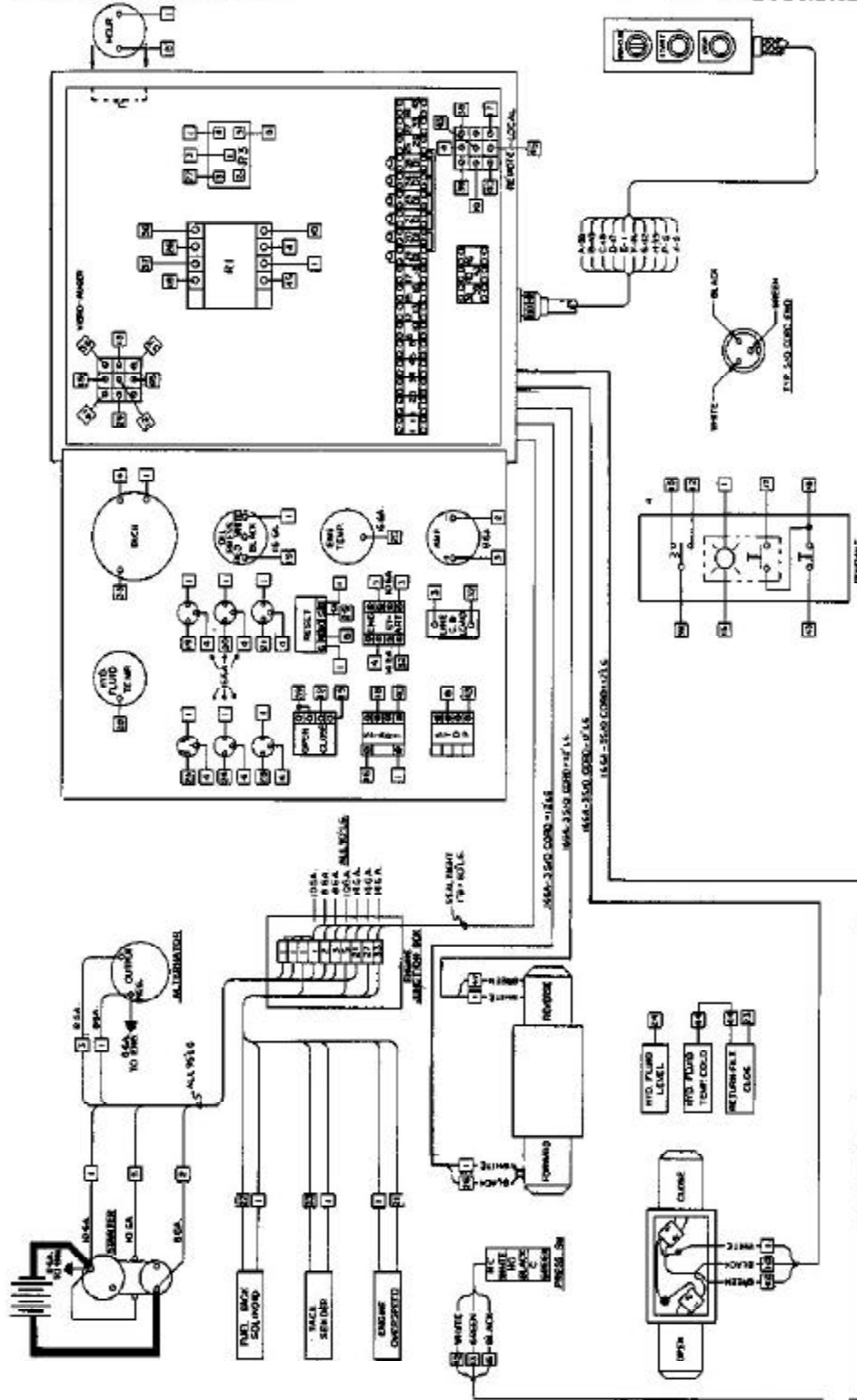



MODEL 815  
VIBRATORY  
DRIVER/EXTRACTOR

# PARTS LIST

## VII. GENERAL DATA

### A. ABBREVIATIONS

The abbreviations shown below are used throughout the parts lists and various other parts of the manual.

ASM.	Assembly
BHCS	Button Head Cap Screw
Cyl.	Cylinder
DC	Direct Current
FHCS	Flat Head Cap Screw
HC	High Collar
HHCS	Hex Head Cap Screw
HHP	Hex Head Pipe Plug
HSSS	Hex Socket Set Screw
Hyd.	Hydraulic
Lg.	Long
mm	Millimeter
Mtg.	Mounting
NPT.	National Pipe Thread
PHMS	Phillips Head Machine Screw
P/N	Part Number
Qty.	Quantity
RHMS	Round Head Machine Screw
Sch.	Schedule
SHCS	Socket Head Cap Screw
SHPP	Socket Head Pipe Plug
SHSS	Socket Head Shoulder Screw
S/N	Serial Number
Sol.	Solenoid

### B. SCREWS AND BOLTS

1. Practically all connections on the unit are made with socket head (Allen) cap screws. These high-strength screws are available at most industrial supply houses.
2. Screws and bolts are designated in the PARTS LIST in abbreviated form. (Refer to sub-section A, above for specific abbreviations.) Listed below is a typical screw description:

5-13UNC x 1.50 LG SHCS

.5 = Diameter  
13UNC = Threads Per Inch  
1.50 LG = Length  
SHCS = Screw Type Abbr.

3. Some screws or bolts require a specific torque when replacing. For identification of these bolts and a more thorough understanding of torque, refer to SECTION IV -K-BOLT TORQUE INFORMATION.



MODEL 815  
VIBRATORY  
DRIVER/EXTRACTOR

# PARTS LIST

## VII. GENERAL DATA

### C. SERIAL NUMBER LOCATIONS

1. The following ICE vibratory units are serial numbered separately:
  - a. Vibrator
  - b. Power unit
  - c. Piling clamps
  - d. Caisson beams
  - e. 90 deg. clamp adapter
  
2. In addition to the serial number plate itself (on vibrators, power units and clamps), the serial number is stamped into each unit in one or more places as follows:
  - a. Vibrator stamped twice - once on top right side of suppressor housing, once on bottom lip of vibration case on right side of motors' side.
  - b. Power unit stamped twice - once on control panel side of unit at right corner of reservoir, once on sub-base inside door below hex-key rack.
  - c. Model 126B universal clamp is stamped three times - once between the cylinder and pile guide, once above the grease fitting, and once on the flange of the cylinder housing.
  - d. Model 127 Z-Pile clamp stamped twice - once in front of cylinder guard, once in back opening of pile guide.
  - e. Model 80 caisson clamp stamped twice - once by the lifting eye, once by the adjusting screw .
  - f. Caisson beams are stamped three times - once on top center, once in center of both sides of flange.
  - g. 90 deg. clamp plate stamped twice - once on top center, once on side.



MODEL 815  
VIBRATORY  
DRIVER/EXTRACTOR

# PARTS LIST

## VIII. ORDERING PARTS

### A. PROCEDURE

1. When ordering parts, be sure to include the model and serial number of the unit or component. The serial number may be located by referring to SECTION VII, SERIAL NUMBER LOCATION. Confirm all telephone orders immediately to avoid duplicating shipment.
2. ORIGINAL EQUIPMENT; Where component serial numbers are given, these apply only to equipment and components originally furnished with the unit. Where equipment has been changed or upgraded these numbers may not be an adequate description.
3. SHIPMENT; State to whom shipment is to be made and method of shipment desired, otherwise our own judgement will be used.
4. SHORTAGES; Claims for shortages or errors should be made immediately upon receipt of parts. No responsibility will be assumed for delay, damage or loss of material while in transit. Broken, damaged or lost material should be refused or a full description made of damage or loss to the carrier agent on the freight or express bill.
5. RETURN OF PARTS; If for any reason you desire to return parts to the factory or to any distributor from whom these parts were obtained, you must first secure permission to return the parts. Shipping instructions will be given along with this permission. A ten percent handling charge must be assessed against the returned shipment unless an error is made by the factory or by the distributor when filling your order.



**MODEL 815  
VIBRATORY  
DRIVER/EXTRACTOR**

# PARTS LIST

## VIII. ORDERING PARTS

### B. FITTING DESCRIPTION KEY

FITT 2 L - 16 M 12 J 00 0 - 00L 0 0 0 1

<p><u>SELECTOR INDEX</u> 2 - INCH FITTING 9 - METRIC FITTING</p> <p><u>CONFIGURATION OR SHAPE OF FITTING</u> S - STRAIGHT FITTING L - 90 Deg. ELBOW V - 45 Deg. ELBOW T - TEE C - CAP P - PLUG U - UNION X - CROSS (FOURTH END FITT'G REQ'D.)</p> <p><u>FIRST END SIZE</u> * IN 1/16THS OF AN INCH (INDEX 2) IN MILLIMETERS (INDEX 9) SEE GENERAL SPECIFICATION SHEET FOR SEQUENCE OF ORDER</p> <p><u>FIRST END FITTING STYLE</u> SEE FITTING STYLE SELECTOR CHART SC-1</p> <p><u>SECOND END SIZE</u> IF APPLICABLE - SEE FIRST END SIZE</p> <p><u>SECOND END FITTING STYLE</u> IF APPLICABLE - SEE FIRST END FITTING STYLE</p> <p><u>THIRD END SIZE</u> IF APPLICABLE - SEE FIRST END SIZE</p> <p><u>THIRD END FITTING STYLE</u> IF APPLICABLE - SEE FIRST END SIZE</p> <p> </p> <p>* EXCEPTIONS 90 = 10"    96 = 6" 92 = 12"    98 = 8" 94 = 14"    99 = NON CODE SIZE</p>	<p><u>MATERIAL</u> 1 - CARBON STEEL 2 - BRASS 4 - STAINLESS STL 5 - AAR MAL IRON 6 - MALLEABLE IRON 8 - FORGED STEEL</p> <p><u>SPECIAL NOTATIONS</u></p> <p><u>PRESSURE RATING</u> 0 - NONE 1 - 125 LB 3 - SCH 40 4 - SCH 80</p> <p><u>INSTALLATION AID OR STYLE OF HEAD</u> 0 - NOT APPLICABLE H - REGULAR HEX Q - SQUARE HEAD (EXT.) R - SQUARE HEAD (INT.) S - HEX HEAD (INT SOCKET) T - HEX HEAD (EXT.)</p> <p><u>LENGTH CODE</u> (ELBOWS &amp; NIPPLES) --L - LONG (ELBOW) --X - EXTRA LONG (ELBOW) --C - CLOSE (NIPPLE)</p> <p>PIPE NIPPLES (LONG) ONLY IN DEC. INCHES FOR INDEX 2 050 = 5.0 INCHES 105 = 10.5 INCHES</p> <p>IN MILLIMETERS FOR INDEX 9 120 = 12.0 MILLIMETERS 084 = 8.4 MILLIMETERS</p> <p><u>FOURTH END SIZE &amp; FITTING STYLE</u> (CROSSES ONLY) SEE FIRST END FITTING SIZE OR END STYLE</p>
--------------------------------------------------------------------------------------------------------------------------------------------------------------------------------------------------------------------------------------------------------------------------------------------------------------------------------------------------------------------------------------------------------------------------------------------------------------------------------------------------------------------------------------------------------------------------------------------------------------------------------------------------------------------------------------------------------------------------------------------------------------------------------------------------------------------------------------------------------------------------------------------------------------------------------------------------------------------------	-------------------------------------------------------------------------------------------------------------------------------------------------------------------------------------------------------------------------------------------------------------------------------------------------------------------------------------------------------------------------------------------------------------------------------------------------------------------------------------------------------------------------------------------------------------------------------------------------------------------------------------------------------------------------------------------------------------------------------------------------------------------------------------------------------------------------------------------------------------------------------------------------------------------------------------



MODEL 815  
VIBRATORY  
DRIVER/EXTRACTOR









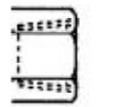

# PARTS LIST

## VIII. ORDERING PARTS

### B. FITTING DESCRIPTION KEY (CONTINUED)

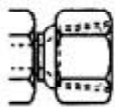
#### FITTING STYLE SELECTOR CHART

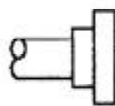
FOR END FITTING STYLE SELECTION

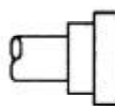
M		JIC MALE 37 Deg. FLARE	J		JIC FEMALE 37 Deg. FLARE ( & SWIVEL )
P		MALE PIPE NPT	Q		FEMALE PIPE NPTF
R		S.A.E. MALE O-RING ( & ADJUSTABLE )	K		S.A.E. FEMALE O-RING
B		JIC MALE 37 Deg. FLARE BULKHEAD	N		FEMALE PIPE NPSM-SWIVEL
D		MALE PIPE NPT SWIVEL	F		SPLIT FLANGE 3000 PSI. CODE 61
S		B.S.P. MALE PIPE	H		SPLIT FLANGE 6000 PSI. CODE 62



MODEL 815  
VIBRATORY  
DRIVER/EXTRACTOR

# PARTS LIST

## VIII. ORDERING PARTS

### C. HOSE DESCRIPTION CODE

The HOSE DESCRIPTION CODE is a 24 digit number enabling easier and quicker identification whenever a hose replacement is desired. The key below explains the structure of the coded number in detail.

	HOSE	125	R01	F	9	24	P	0	20	L0395	S
<u>Hose I.D.</u> In Inches : 2 place decimal (125 = 1-1/4") (050 = 1/2") etc.											
<u>SAE or Manufacture Rating</u> (PT4 = Powertrack) (AQ1 = Aeroquip H-Pac) (TF1 = Teflon) (R01 = SAE Rating 100R1) etc.											
<u>First End - Type of Fitting</u> (F = 3000 lb Flange) (P = Male Pipe) (H = 6000 lb Flange) (M = 37 deg. Male JIC) (J = 37 deg Female Swivel)											
<u>First End Bend - Bend Angle</u> (0 = None) (9 = 90 deg) (3 = 30 deg) etc.											
<u>First End - Size in 1/16 ths</u>											
<u>Second End - Type of Fitting</u> (See code for First End)											
<u>Second End - Bend Angle</u> (See code for First End Bend)											
<u>Second End - Size in 1/16 ths</u>											
<u>Length in Inches</u> 1 Place Decimal (0395 = 39-1/2") (1242 = 124-1/4") etc.											
<u>Special Code</u> (0 = None) (S = Spring Guard) (L = S.S.Braid) (D = Offset)											





MODEL 815  
VIBRATORY  
DRIVER/EXTRACTOR

# PARTS LIST

## VIII. ORDERING PARTS

### D. PARTS IDENTIFICATION

1. Parts lists and drawings are included on the following pages for the equipment components shown below:

a.	VIBRATION SUPPRESSOR	800057
b.	VIBRATION CASE	810085
c.	DISTRIBUTION BLOCK	810087
d.	HOSE ASSEMBLIES -INTERCONNECTING	800053
e.	POWER UNIT - ENCLOSURE	810151
f.	CONTROL BOX	810451
g.	POWER UNIT - INTERNAL	800127
h.	JUNCTION BOX	810145
i.	CONTROL MANIFOLD	810447
j.	CLAMP MANIFOLD	810449
k.	MODEL 126B UNIVERSAL CLAMP	800327
l.	CLAMP EXTENSION-8FT.	800063
m.	90 DEG. ADAPTER	800049
n.	CAISSON BEAM-7 FT.	800045
o.	CAISSON BEAM-11 FT.	800163
p.	MODEL 80B CAISSON CLAMP	800047
q.	MODEL 127 Z PILE CLAMP	800041
r.	MODEL 127 Z CYLINDER	810175
s.	PENDANT EXTENSION CABLE	800059

2. The spare parts list SECTION VIII - RECOMMENDED SPARE PARTS contains spare parts which may be very useful in keeping down-time to a minimum, especially in remote or secluded job sites where unforeseen communication problems could cause delay of the delivery of an awaited part.

These RECOMMENDED SPARE PARTS may be ordered beforehand, individually or as a package group as shown in the PARTS LIST.





MODEL 815  
VIBRATORY  
DRIVER/EXTRACTOR

# PARTS LIST

VIBRATION SUPPRESSOR

800057

<u>Item</u>	<u>Part Number</u>	<u>Qty.</u>	<u>Description</u>
1	100002	1	Vibration Case Adapter
2	100003	8	Elastomer
3	100005	37	.625-11UNCx1.75 LG.SHCS
4	100007	58	.625 Lock Washer
5	110105	1	Hose Clamp
6	100011	6	.5-13UNCx2.00 LG.SHCS
7	100013	1	Hose Clamp
8	110317	1	Hose Clamp
9	100015	2	Hose Clamp
10	100814	1	Sealant
11	100019	1	Coupler Guard
12	100021	4	.5-13UNCx1.50 LG.SHCS
13	110733	1	Terminal Manifold
14	100025	4	.5-13UNC x 4.50 LG SHCS
15	100027	12	.50 Hi-Collar Lockwasher
16	110273	1	Manifold Block
18	100032	1	Relief Valve (RV3)
19	110281	1	Filter (F3)
20	110113	1	Filter Element
21	110119	2	#225-O-Ring
22	110115	1	FITT2S-24P24N000_000H001
23	100041	2	FITT2S-06P06N000-000H001
24	100043	1	FITT2S-12P12N000-000H001
25	100596	4	Split Flange Half (#24)
26	100119	8	.5-13UNC x 1.25 LG SHCS
27	100049	2	Split Flange Half (#12)
28	100051	4	.375-16UNC x 1.00 LG SHCS
29	100053	2	FITT2S-06M06R000-000H001
30	100055	4	FITT2S-06M06B000-000H001
31	100057	4	FITT2C-06J000000-000H001
32	100059	1	Suppressor Housing
33	100063	3	FITT2P-16P000000-000S007
35	400545	14	.75-10UNC x 3.00 LG SHCS
36	100069	14	.75 Lock Washer
39	400157	22	.625-11UNC x 2.75 LG SHCS
41	100074	2	Stop Block
42	100773	6	.625-11UNC x 4.25 LG SHCS
44	810087	1	Distribution Block
46	100085	38	.625-11UNC x 2.25 LG SHCS
47	100086	38	.625-11UNC Flange Nut



MODEL 815  
VIBRATORY  
DRIVER/EXTRACTOR

# PARTS LIST

VIBRATION SUPPRESSOR (Continued)

800057

<u>Item</u>	<u>Part Number</u>	<u>Qty.</u>	<u>Description</u>
48	100084	4	.5-13UNC x 5.0 LG SHCS
50	100817	2	Hose Clamp Bracket
51	100819	2	Double Hose Clamp
52	100821	2	Gang Hose Clamp
53	100823	2	Adapter Bracket
55	110215	1	#239-O-Ring
56	110217	1	#239-Back-Up Washer
57	110275	1	Label Group
58	100829	4	.5-13UNC x 3.50 LG SHCS
60	100827	10	.375-16UNC x 3.50 LG SHCS
61	400149	10	.375 Lock Washer
66	100915	4	Stop Block Plate
67	100575	6	.625-11UNC x 1.25 LG SHCS
68	110269	1	FITT2S-32M24P000-000H001
70	110381	1	Hose Guide
71	110383	1	Hose Guide Rod
74	130243	11	Tie Down
75	400277	2	ICE Logo Plate
76	110723	1	Check Valve Body
77	110731	1	Check Valve (CV6)
78	110735	4	.5-13UNC x 2.50 LG SHCS
79	100097	2	#214-O-Ring
80	110627	2	8 - Logo Plate
81	110629	2	1 - Logo Plate
82	110514	2	5 - Logo Plate
83	810085	1	Transmission Case
85	130381	10	Rivet
86	130117	4	.375-16UNC x 1.50 LG SHCS
87	100423	1	FITT2P-08P000000-000S007
88	100991	4	Load Gage Decal



MODEL 815  
VIBRATORY  
DRIVER/EXTRACTOR

# PARTS LIST

VIBRATION CASE

810085

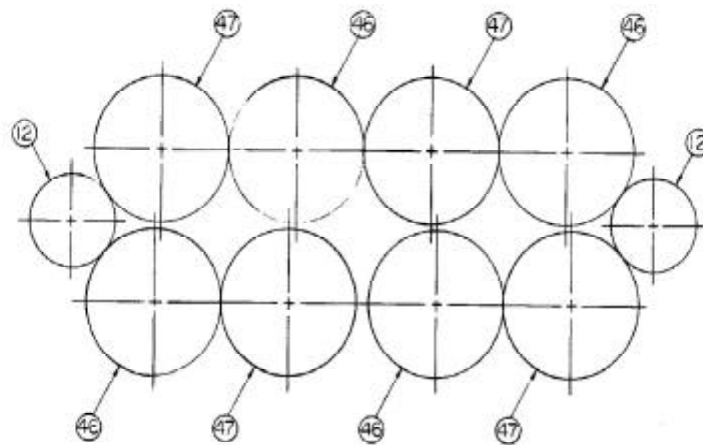
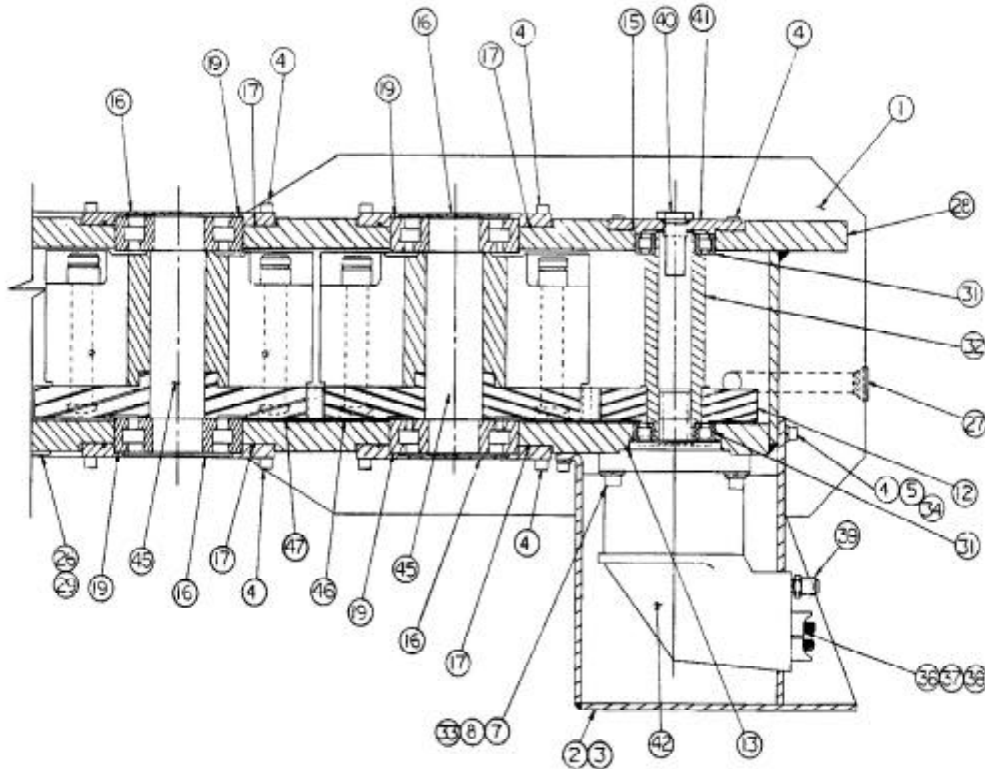

815 GEAR DIAGRAM



MODEL 815  
VIBRATORY  
DRIVER/EXTRACTOR

# PARTS LIST

VIBRATION CASE

810085

<u>Item</u>	<u>Part Number</u>	<u>Qty.</u>	<u>Description</u>
1	810083	1	Vibration Case
2	110073	1	Left Motor Guard
3	110075	1	Right Motor Guard
4	100119	124	.5-13UNC x 1.25 LG. SHCS
5	100121	28	.5 Lock Washer
7	100067	8	.75-10UNC X 2.25 LG SHCS
8	100589	8	.75 Flat Washer
12	110185	2	Motor Gear
13	110195	2	#163-O-Ring
15	110197	2	#159-O-Ring
16	100165	16	Bearing Cover
17	100167	16	#266-O-Ring
19	100169	16	Roller Bearing
26	100185	1	Sight Gage
27	100187	2	FITT2P-12P000000-000S0M7
28	100720	1	Gasket
29	100735	3	Oil (Gallon)
31	110191	4	Roller Bearing
32	110187	2	Splined Shaft
33	100069	8	.75 Lock Washer
34	100483	8	.5 Flat Washer
36	810309	8	#20 Split Flange Half
37	110995	16	14mm x 55mm SHCS
38	110997	16	14mm Lock Washer
39	110984	2	FITT2S-12S08M000-000H0F1
40	810229	2	Centrifugal Breather
41	110855	2	Bearing Cap
42	110999	2	Drive Motor (M)
45	150003	8	Eccentric Shaft
46	810411	4	Eccentric Gear Asm.
47	810415	4	Eccentric Gear Asm.



**MODEL 815  
VIBRATORY  
DRIVER/EXTRACTOR**

# **PARTS LIST**

**DISTRIBUTION BLOCK**

**810087**

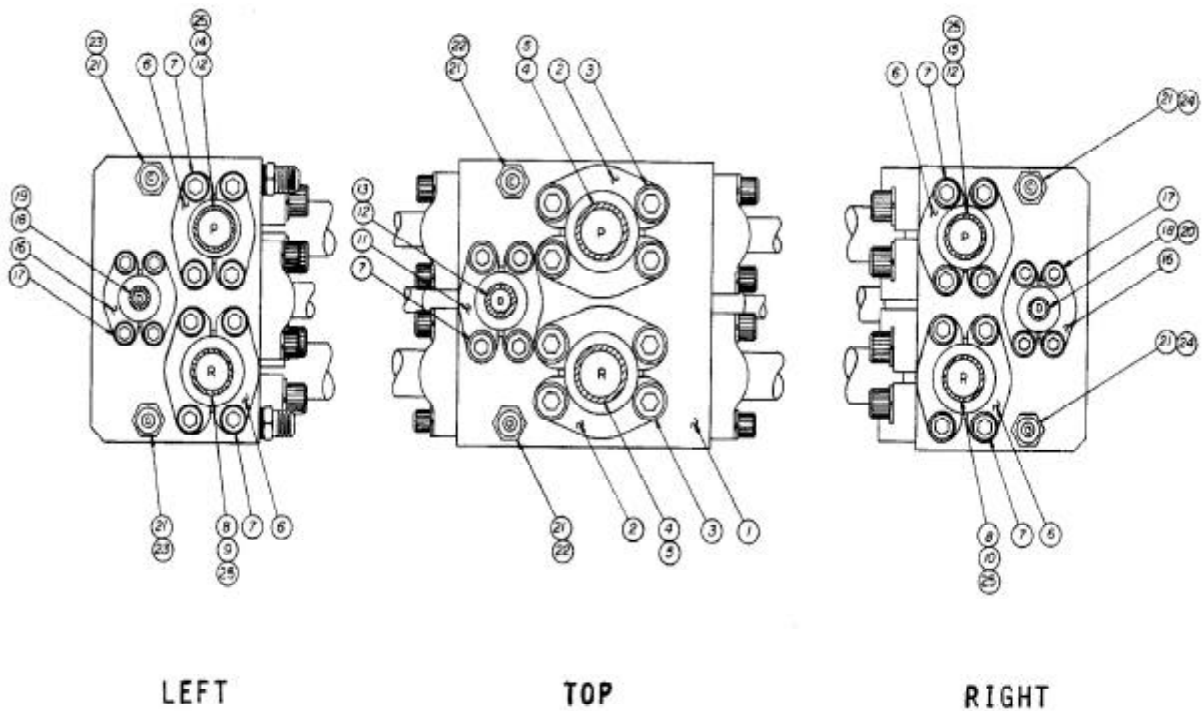

**VIEWED FROM MOTOR SIDE OF VIBRATOR**



MODEL 815  
VIBRATORY  
DRIVER/EXTRACTOR

# PARTS LIST

DISTRIBUTION BLOCK

810087

<u>Item</u>	<u>Part Number</u>	<u>Qty.</u>	<u>Description</u>
1	110121	1	Distribution Block
2	100596	4	Split Flange Half (#24)
3	100119	8	.5-13UNC x 1.25 LG SHCS
4	110119	4	#225-O-Ring
5	110123	2	HOSE150PT4F024F024L0875S
6	100089	8	Split Flange Half (#16)
7	100051	20	.375-16UNC x 1.00 LG SHCS
8	100091	4	#219-O-Ring
9	110992	1	HOSE100R01F016H920L0660S
10	110988	1	HOSE100R01F016H920L0500S
11	100049	2	Split Flange Half (#12)
12	100097	2	#214-O-Ring
13	100099	1	HOSE075R01F012F012L0880S
14	110994	1	HOSE100R10F016H920L0690S
15	110990	1	HOSE100R10F016H920L0530S
16	100103	4	Split Flange Half (#8)
17	100105	8	.312-18UNC x 1.00 LG SHCS
18	100107	2	#210-O-Ring
19	110329	1	HOSE050R01F008J908L0640S
20	110327	1	HOSE050R01F008J908L0480S
21	100053	6	FITT2S-06M06R000-000H001
22	100111	2	HOSE038R02J006J006L0875S
23	110633	2	HOSE038R02J006J006L0370S
24	100108	2	HOSE038R02J006J006L0200S
25	100037	4	#222-O-Ring





**MODEL 815  
VIBRATORY  
DRIVER/EXTRACTOR**

# PARTS LIST

**HOSE ASSEMBLIES - INTERCONNECTING**

**800053**

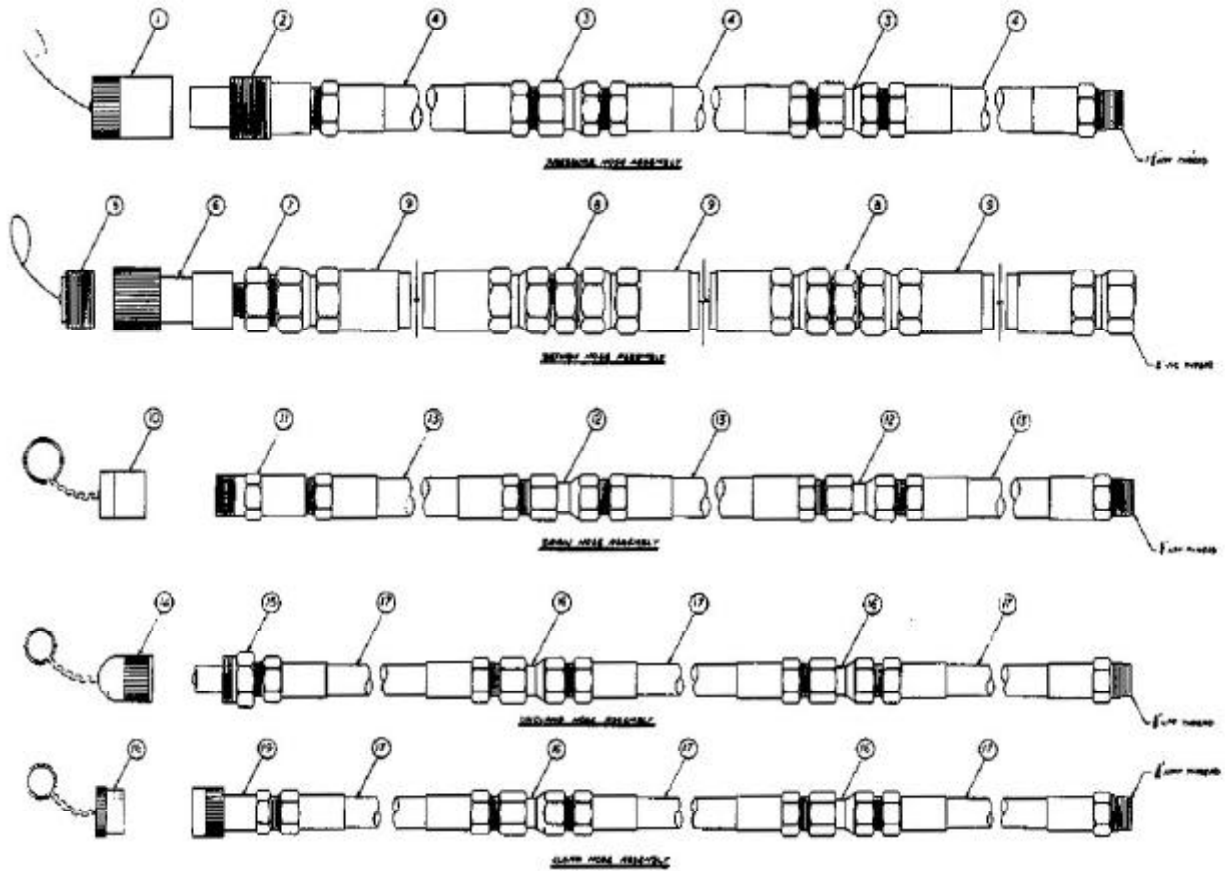



MODEL 815  
VIBRATORY  
DRIVER/EXTRACTOR

# PARTS LIST

HOSE ASSEMBLIES - INTERCONNECTING

800053

<u>Item</u>	<u>Part Number</u>	<u>Qty.</u>	<u>Description</u>
1	110955	1	Dust Cap (1-1/2)
2	110690	1	Male Disconnect (1-1/2)
3	110139	2	FITT2S-24Q24N000-000H001
4	110141	3	HOSE150PT4P024P024L60000
5	110957	1	Dust Plug (1-1/2)
6	110692	1	Female Disconnect (1-1/2)
7	110269	1	FITT2S-32M24P000-000H001
8	110271	2	FITT2S-32M32M000-000H001
9	110970	3	HOSE200R02J032J032L60000
10	400253	1	Dust Cap (3/4)
11	400251	1	Male Disconnect (3/4)
12	100243	2	FITT2S-12Q12N000-000H001
13	100241	3	HOSE075R02P012P012L62000
14	100257	1	Dust Cap (3/8)
15	100245	1	Male Disconnect (3/8)
16	100249	4	FITT2S-06Q06N000-000H001
17	100247	6	HOSE038R02P006P006L62000
18	100737	1	Dust Plug (3/8)
19	100777	1	Female Disconnect (3/8)
	130243	20	Rubber Tie Down



MODEL 815  
VIBRATORY  
DRIVER/EXTRACTOR

# PARTS LIST

POWER UNIT ENCLOSURE

810151

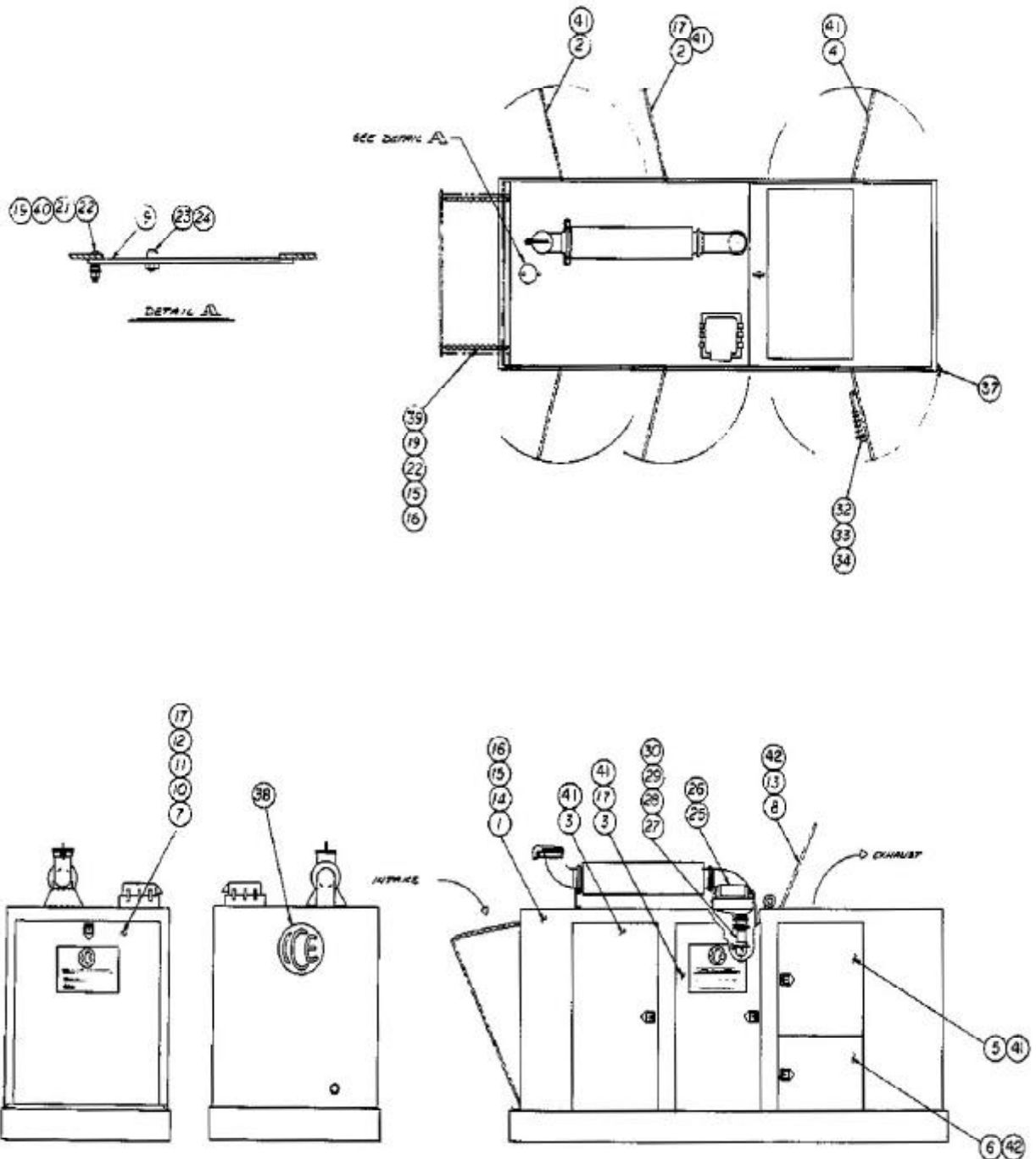



MODEL 815  
VIBRATORY  
DRIVER/EXTRACTOR

# PARTS LIST

POWER UNIT ENCLOSURE

810151

<u>Item</u>	<u>Part Number</u>	<u>Qty.</u>	<u>Description</u>
1	110305	1	Unit Cover
2	110299	2	Cover Door
3	110301	2	Cover Door
4	110303	1	Cover Door
5	110311	1	Cover Door
6	110313	1	Cover Door
7	110363	1	Intake Door
8	110307	1	Exhaust Door
9	100761	1	Water Fill Door
10	100271	2	Shoulder Bolt
11	100273	2	.625-11UNC Hex Nut
12	100007	2	.625 Lock Washer
13	100277	1	Exhaust Door Clip
14	100105	15	.312-18UNC x 1.00 LG SHCS
15	100287	19	.312 Lock Washer
16	100289	12	.312-18UNC Hex Nut
17	100290	3	ICE Decal
19	100309	5	.312-18UNC x 1.00 LG BHCS
21	100797	5	.312-18UNC Esna Nut
22	100293	20	.312 Flat Washer
23	100648	1	.375-16UNC x .88 LG SHCS
24	100535	1	.375-16UNC Hex Nut
25	110421	1	Air Cleaner Cover
26	110423	1	Air Cleaner Element
27	110425	1	Air Intake Sleeve
28	110427	1	Air Intake Tube
29	110429	1	Air intake Elbow
30	110431	2	Band Clamp
32	100600	1	Hex Key Rack
33	810045	1	Hex Key Group
34	100651	1	24 Volt Test Light
37	110221	1	Control Door Latch
38	400277	1	ICE Logo Plate
39	110881	72	Chain (inches)
40	110847	2	.375 Spring Washer
41	100834	10	5" Door Hinge
42	100466	7	3" Door Hinge



**MODEL 815  
VIBRATORY  
DRIVER/EXTRACTOR**

# PARTS LIST

CONTROL BOX ASSEMBLY

810451

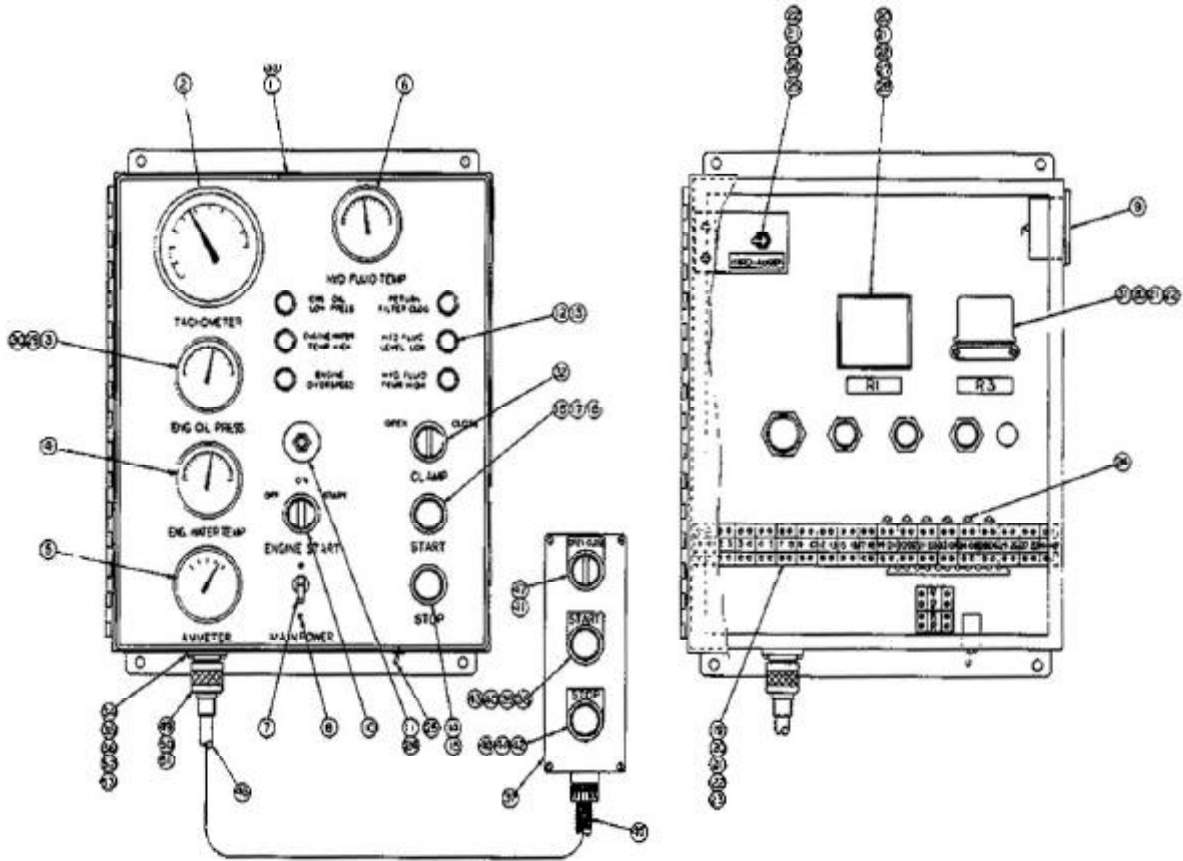



MODEL 815  
VIBRATORY  
DRIVER/EXTRACTOR

# PARTS LIST

CONTROL BOX ASSEMBLY

810451

<u>Item</u>	<u>Part Number</u>	<u>Qty.</u>	<u>Description</u>
1	110652	1	Control Box Enclosure
2	110650	1	Tachometer
3	100329	1	Oil Press. Gauge
4	110697	1	Water Temperature Gage
5	110371	1	Ammeter
6	110640	1	Hyd. Fluid Temp. Gage (TS-2)
7	400141	1	Circuit Breaker (CB-2)
8	100331	2	#6-32 x .25 LG BHCS
9	100343	1	Hour Meter (M1)
10	110615	1	Start Switch
11	110387	1	Reset Button
12	100355	6	Warning Light (L1-L6)
13	130305	6	757 Light Bulb
14	100363	1	Stop Button
15	100365	1	Stop Dust Cover
16	110598	1	Start Button (w/ Clamp Light)
17	110594	1	Guard
18	110596	1	Lens
19	110569	15	Terminal Strip (inches)
20	110861	10	#10-32 x .5 LG PHMS
21	400163	10	#10-32 Hex Nut
22	400161	10	#10 Lock Washer
23	110567	20	Terminal Block
24	100413	7	Diode (D1-D8)
25	140361	2	Toggle Switch
26	100572	1	Switch Bracket
27	140281	3.5	Relay Mounting Track
28	110584	1	Relay (R1)
29	110415	11	Oil Pressure Hose (feet)
30	100333	1	FITT2L-04E01Q000-000H002
31	110604	1	Relay (R3)
32	130155	1	Clamp Switch
33	810455	1	570C Label Group
34	110763	1	Female Amphenol Insert
35	100397	1	Female Amphenol Plug
36	110754	4	#6-32 x .375 LG RHMS
37	130153	1	Pendant Box Enclosure
38	110598	1	Start Button (w/ Clamp Light)
39	110596	1	Lens
40	110594	1	Guard



MODEL 815  
VIBRATORY  
DRIVER/EXTRACTOR

# PARTS LIST

CONTROL BOX ASSEMBLY

810451

<u>Item</u>	<u>Part Number</u>	<u>Qty.</u>	<u>Description</u>
41	100401	1	Open/Close Name Plate
42	100363	1	Stop Button
43	100407	1	Start Name Plate
44	100405	1	Stop Name Plate
45	100371	1	Strain Relief
46	130365	50	Pendant Cable (feet)
47	130155	1	Switch
48	100365	1	Stop Dust Cap
49	110761	1	Male Amphenol Insert
50	100395	1	Male amphenol Plug
51	100375	1	Strain Relief
52	110696	4	#6 Lock Washer
53	110694	4	#6-32 Hex Nut



**MODEL 815  
VIBRATORY  
DRIVER/EXTRACTOR**

# PARTS LIST

**POWER UNIT-INTERNAL**

**800127**

**(side and top views)**

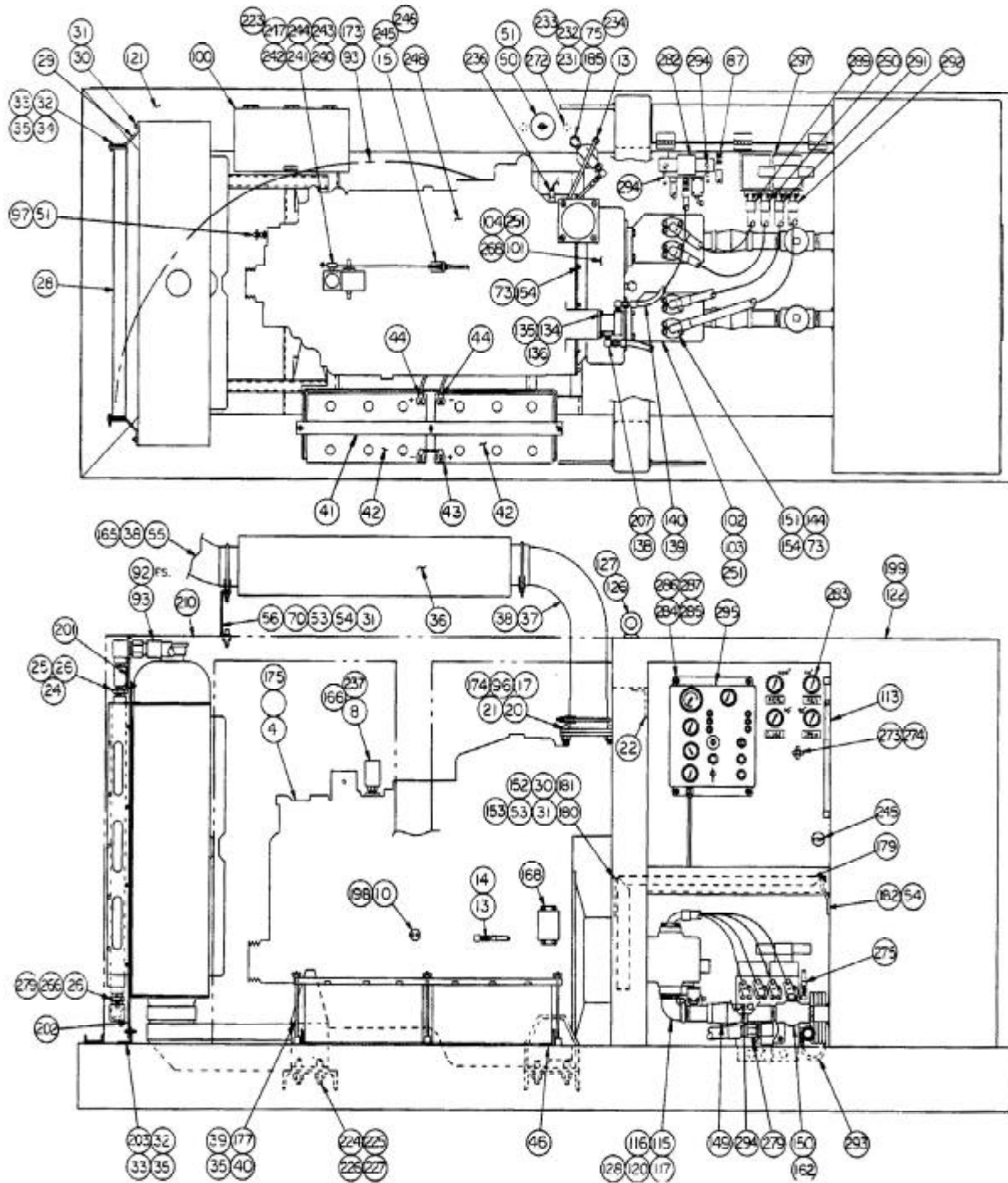





**MODEL 815  
VIBRATORY  
DRIVER/EXTRACTOR**

# PARTS LIST

POWER UNIT-INTERNAL

800127

(end view and coupler panel)

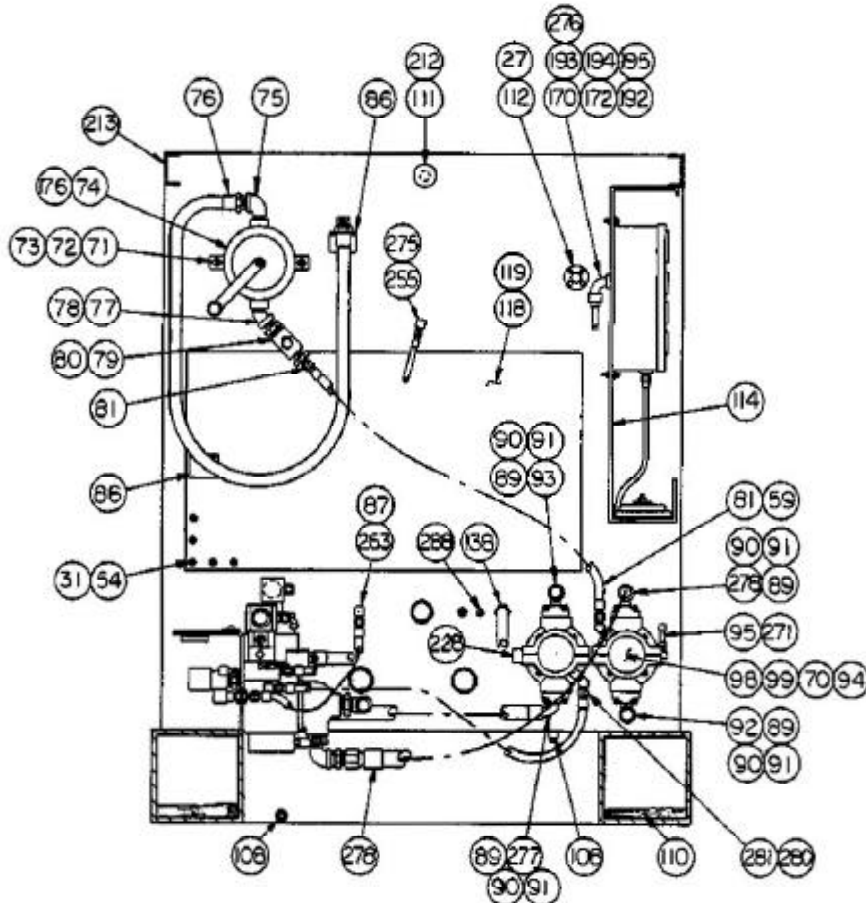
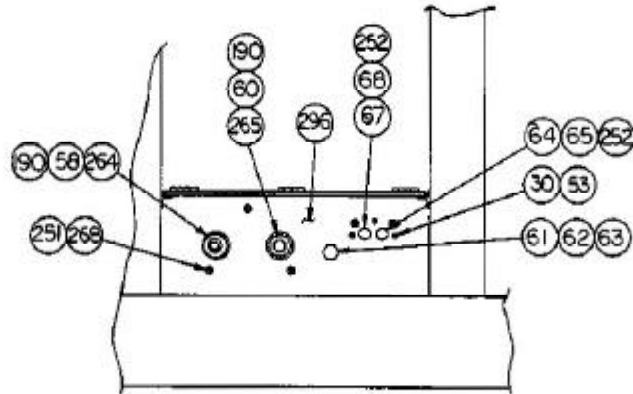



MODEL 815  
VIBRATORY  
DRIVER/EXTRACTOR

# PARTS LIST

POWER UNIT-INTERNAL

800127

<u>Item</u>	<u>Part Number</u>	<u>Qty.</u>	<u>Description</u>
4	110375	1	Diesel Engine (E)
8	110447	1	Tachometer Drive Adapter
10	110369	1	FITT2S-06P04Q000-000H001
13	110203	2	FITT2S-04M04P000-000H001
14	110395	1	HOSE025R01J004J004L04600
15	110647	1	Throttle Bracket
17	100273	4	.625-11UNC Hex Nut
20	110510	1	Exhaust Adapter
21	110225	4	.625-11UNC x 1.5 LG BHCS
22	110655	1	Cable Bracket
24	110443	2	FITT2L-24M24Q000-0000001
25	110437	2	1.5 x 5.50 LG Nipple
26	100547	3	FITT2S-32P24Q000-000H306
27	110564	4	.25-20UNC x 2.25 LG RHMS
28	100551	1	Heat Exchanger (HE)
29	110297	2	Oil Cooler Bracket
30	100648	23	.375-16 x .875 LG SHCS
31	400151	46	.375 Flat Washer
32	100105	18	.312-18UNC x 1.0 LG SHCS
33	100289	18	.312-18UNC Hex Nut
34	100287	10	.312 Lock Washer
35	100293	39	.312 Flat Washer
36	110504	1	Muffler
37	110508	1	Muffler Inlet Elbow
38	100297	3	Exhaust Pipe Clamp
39	400231	3	Hold Down Stud
40	100831	3	.312-18UNC Wing Nut
41	810169	1	Battery Hold Down
42	100529	2	Battery (EB1-2)
43	110653	1	Battery Cable - Jumper
44	110755	2	Battery Cable - 15"
46	110391	1	Battery Box
50	100417	1	Fuel Fill Cap
51	100419	2	Fuel Cap Vent
53	400149	25	.375 Lock Washer
54	100535	44	.375-16UNC Hex Nut
55	110506	1	Muffler Outlet Elbow
56	110512	1	Muffler Support
58	110957	1	1.5 Dust Plug
59	110641	1	FITT2V-12M08P000-000H001
60	110955	1	1.5 Dust Cap
61	100387	1	FITT2S-12P12B000-000H001



MODEL 815  
VIBRATORY  
DRIVER/EXTRACTOR

# PARTS LIST

POWER UNIT-INTERNAL

800127

Item	Part Number	Qty.	Description
62	400095	1	.75 Female Q.D. (QD5)
63	400121	1	.75 Dust Plug
64	100245	1	.375 Male Q.D. (QD4)
65	100257	1	.375 Dust Cap
67	100777	1	.375 Female Q.D. (QD3)
68	100737	1	.375 Dust Plug
70	100051	10	.375-16UNC x 1.00 LG.SHCS
71	100439	2	.437-14UNC x 1.75 LG SHCS
72	400153	2	.437 Flat Washer
73	100443	24	.437 Lock Washer
74	100447	1	Hand Pump (MP)
75	110377	2	FITT2L-16P16Q000-0000306
76	400215	1	HOSE100R01P016P016L08400
77	110385	1	FITT2V-16P16Q000-0000306
78	100449	1	FITT2S-16P16P000-000H001
79	100451	1	Check Valve (CV4)
80	300119	1	FITT2S-16P12M000-000H001
81	100941	1	HOSE075R01J012J012L04400
86	110379	2	Hose Bracket
87	130201	1	HOSE075R01J012J012104000
89	100596	8	#24 Split Flange
90	110119	4	#225-O-Ring
91	100119	16	.5-13UNC x 1.25 LG SHCS
92	110467	1	HOSE150R01J024F924L16600
93	110469	1	HOSE150R01J024F924L14300
94	110511	8	Seal Washer
95	100775	1	Visual Indicator (GA3)
96	100007	4	.625 Lock Washer
97	100189	1	FITT2S-08P04Q000-000H001
98	810481	2	Return Filter Asm. (F2)
99	810117	4	K10 Element Asm.
100	100558	1	Tool Box
101	110488	1	Multi-Pump Drive Adapter
102	110490	2	Drive Pump (P1)
103	100614	8	.5-13UNC x 1.50 LG HHCS
104	100735	4	Transmission Oil/Gal.
108	100423	4	FITT2P-08P000000-000S007
111	100455	1	Breather
112	100314	1	Float Switch (FS)
113	110355	1	Level Gage
114	110644	1	Control Box
115	100946	2	MFP Flange



MODEL 815  
VIBRATORY  
DRIVER/EXTRACTOR

# PARTS LIST

POWER UNIT-INTERNAL

800127

Item	Part Number	Qty.	Description
116	400379	2	#232-O-Ring
117	100011	8	.5-13UNC x 2.0 LG. SHCS
118	110289	1	Clean Out Cover
119	110365	1	Cover Gasket
120	100962	2	FITT2L-40Q40P000-0000306
121	810143	1	Subbase Asm.
122	110287	1	Reservoir
126	100460	1	Lifting Eye
127	100722	1	Roll Pin
128	110344	2	FITT2S-40P000000-03500001
134	110401	1	Clamp Pump (P2)
135	100513	2	.5-13UNC x 1.5 LG. SHCS
136	100027	2	.5 Hi-Collar Lock Washer
138	110831	1	HOSE100R01P016P016L07000
139	100787	1	FITT2L-08M08R000-000H001
140	110470	1	HOSE050PT4J008J008L03500
144	100037	4	#222-O-Ring
149	130139	2	2.5 Flexible Coupling
150	400117	2	Stop Cock
151	100045	4	#20 Split Flange Half
152	130209	4	Hex Tek Screw
153	100468	1	Top Baffle
154	100462	20	.437-14UNC x 1.25 LG. HHCS
162	110464	2	FITT2S-40P000000-1400301
165	110695	1	6" Rain Cap
166	110631	1	Tachometer Adapter Seal
168	810145	1	570 Engine Junction Box
170	110693	1	1"-90 Deg Compression Fitting
172	110231	3	S/O Cord - 12" LG
173	130243	3	Rubber Tie Down
174	110753	1	Exhaust Gasket
175	110751	1	Volt Regulator Harness
176	130091	1	Hand Pump Mounting Bracket
177	110767	3	Hold Down Block
179	110811	1	Top Cover
180	110813	1	Baffle
181	110817	1	Baffle
182	110815	2	Clip
185	110819	1	Suction Filter Tube
190	110037	2	FITT2S-24P24P000-000H001
192	100853	3	90 Deg S/O Compression Fitting
193	110839	1	1.0 Plastic Bushing



MODEL 815  
VIBRATORY  
DRIVER/EXTRACTOR

# PARTS LIST

POWER UNIT - INTERNAL

800127

<u>Item</u>	<u>Part Number</u>	<u>Qty.</u>	<u>Description</u>
194	100843	3	.5 Lock Nut
195	110841	3	.5 Plastic Bushing
198	110871	1	FITT2V-04P04E000-000H002
201	110887	1	Top Air Shield
202	110889	2	Side Air Shield
203	110891	1	Bottom Air Shield
207	100783	1	FITT2L-16M16R000-000H001
210	810151	1	Power Unit Cover
212	110909	1	.75 x 15"LG SCH 40 Pipe
213	110707	2	4" Channel x 31"LG
223	400161	2	#10 Lock Washer
224	400069	8	.75-10UNC x 2.0 LG SHCS
225	100589	8	.75 Flat Washer
226	100069	8	.75 Lock Washer
227	100587	8	.75-10UNC Hex Nut
228	100602	1	Pressure Switch (PS3)
231	120423	1	Water Separator
232	120425	1	FITT2S-16P16P000-1000301
233	100715	1	FITT2S-16P06Q000-000H001
234	400227	1	FITT2L-06M06P000-0000001
236	130467	1	Tachometer Sender
237	110972	1	Overspeed Switch
240	110968	1	Key
241	110966	1	Shut Down Arm
242	110964	1	Pivot
243	110962	1	Clamp
244	110960	1	Shim
245	100345	1	Stop Cable
246	100429	1	Wiper
247	110861	2	#10-32 x .5 LG PHMS
248	400245	1	Wire Bundle Bracket
251	100121	19	.5 Lock Washer
252	110794	2	FITT2S-06P06P000-000H001
255	140581	1	FITT2L-06M04P000-0000001
263	100489	1	FITT2L-12M12P000-0000001
264	110692	1	1.5 Female Q.D. (QD1)
265	110690	1	1.5 Male Q.D. (QD2)
266	100588	1	FITT2L-24M24P000-000L001
268	100445	11	.5-13UNC x 1.00 LG. SHCS
271	300197	1	FITT2L-04P04Q000-0000306
272	120523	2	Fuel Base Magnet



MODEL 815  
VIBRATORY  
DRIVER/EXTRACTOR

# PARTS LIST

POWER UNIT - INTERNAL

800127

<u>Item</u>	<u>Part Number</u>	<u>Qty.</u>	<u>Description</u>
273	110417	1	Engine Throttle
274	110479	1	Throttle Clevis
275	100228	1	HOSE038R02J006J006L06100
276	110785	64	1"Seal Tight
277	110588	1	HOSE150R01F924J024L02050
278	110780	1	HOSE150R01F924J024L04900
279	110586	1	HOSE150R01J024J024L12900
280	110019	1	HOSE075R01J012J012L04800
281	300481	1	FITT2L-12M08P000-0000001
282	810449	1	570D Clamp Manifold
283	110600	4	Pressure Gage (GA1-4)
284	100557	4	.25-20UNC x .75 LG SHCS
285	100598	4	.25-20UNC Hex Nut
286	100597	4	.25 Flat Washer
287	100559	4	.25 Lock Washer
288	110590	1	Hyd. Temp. Switch (TS-1)
289	110480	1	HOSE100PT4F016F920L03900
290	110478	1	HOSE100PT4F016F920L04000
291	110476	1	HOSE100PT4F016F920L04100
292	110474	1	HOSE100PT4F016F920L04350
293	110680	1	HOSE019R01J004J004L40000
294	130205	3	HOSE019R01J004J004L09000
295	810451	1	570D Control Box Asm.
296	110756	1	Coupler Panel
297	810447	1	570D Drive Manifold Asm.



MODEL 815  
VIBRATORY  
DRIVER/EXTRACTOR

# PARTS LIST

JUNCTION BOX

810145

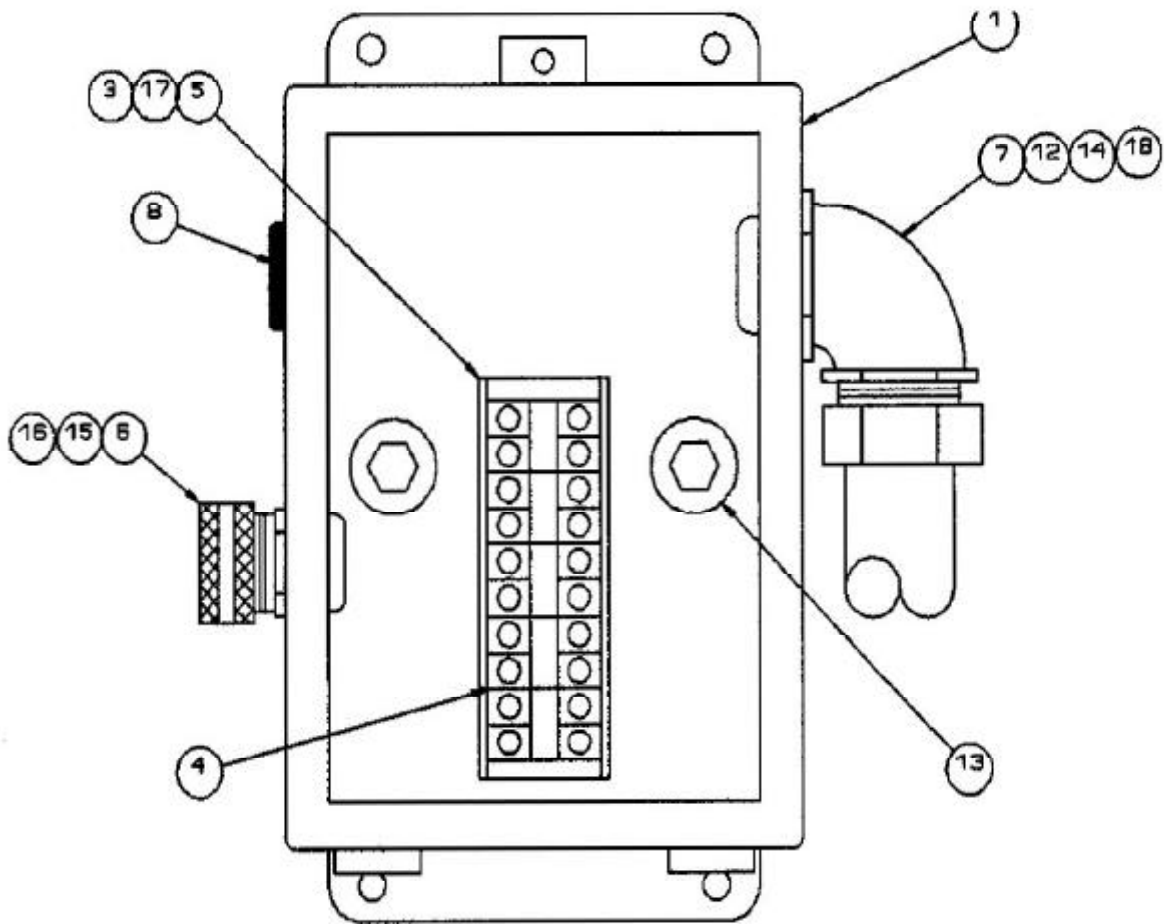



MODEL 815  
VIBRATORY  
DRIVER/EXTRACTOR

# PARTS LIST

JUNCTION BOX

810145

<u>Item</u>	<u>Part Number</u>	<u>Qty.</u>	<u>Description</u>
1	110699	1	Junction Box
3	400163	2	10-32 Hex Nut
4	110567	5	Terminal Block
5	110569	1	Terminal Mounting Channel
6	100855	1	Straight Wire Connector
7	110693	1	90 Deg. Connector
8	110701	1	Grommet
12	110785	6	Seal Tight
14	110839	1	Plastic Bushing (1.0)
15	110843	1	Lock Nut (.5)
16	110841	1	Plastic Bushing (.5)
17	110649	2	10-32 x .375 Lg PHMS
18	110845	1	Lock Nut (1.0)





**MODEL 815  
VIBRATORY  
DRIVER/EXTRACTOR**

# PARTS LIST

## CONTROL MANIFOLD ASSEMBLY

810447

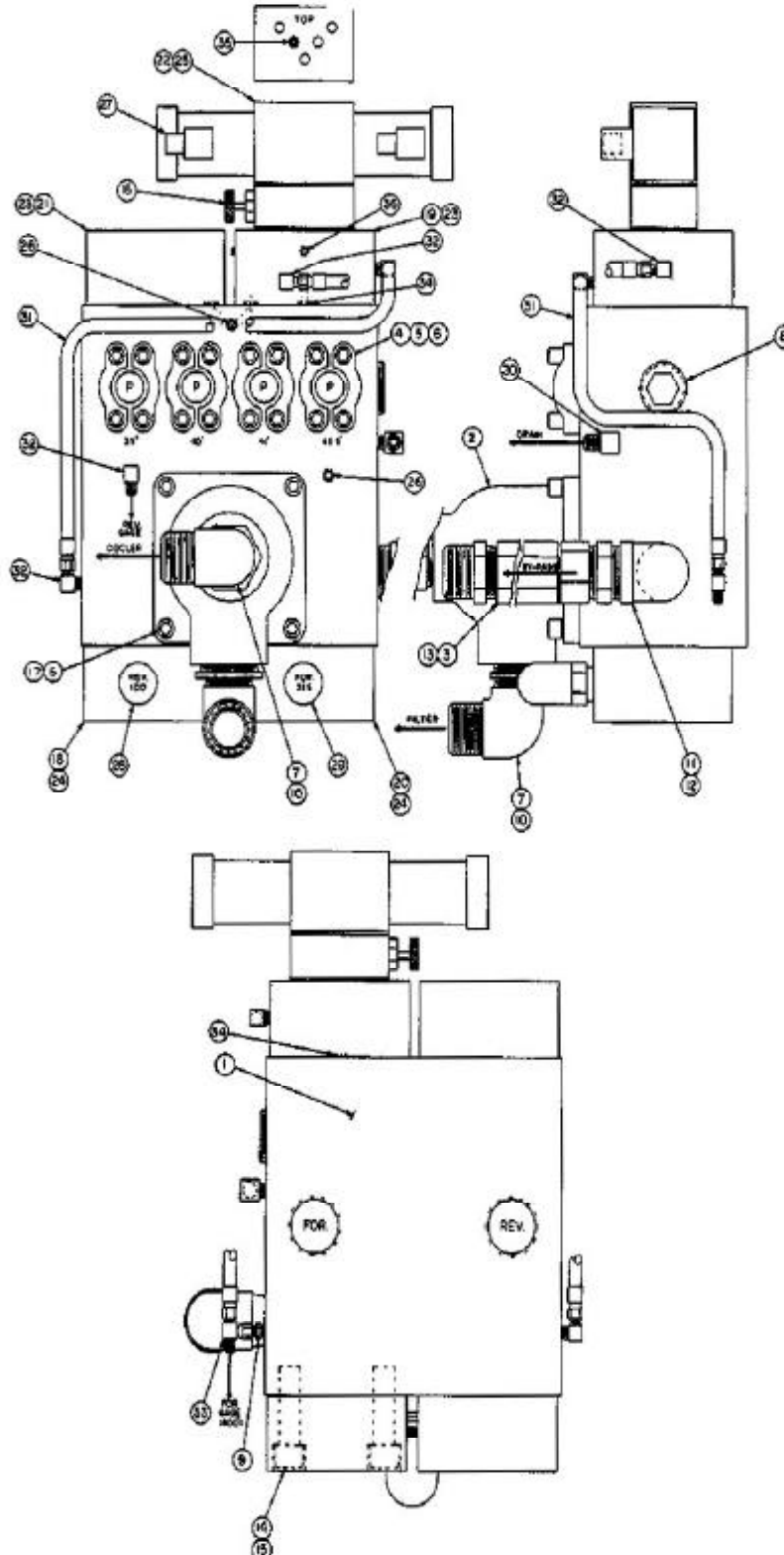



MODEL 815  
VIBRATORY  
DRIVER/EXTRACTOR

# PARTS LIST

CONTROL MANIFOLD ASSEMBLY

810447

<u>Item</u>	<u>Part Number</u>	<u>Qty.</u>	<u>Description</u>
1	110516	1	Manifold Block
2	110628	1	Cooler Valve (V-3)
3	130339	1	Check Valve (CV-2)
4	100089	8	#16 Split Flange Half
5	100091	4	#219-O-Ring
6	100143	20	.375-16UNC x 1.25 Lg SHCS
7	100588	2	FITT2L-24M24P000-0000001
8	110055	1	FITT2P-20P000000-000S007
9	110203	1	FITT2S-04M04P000-000H001
10	100547	2	FITT2S-32P24Q000-000H001
11	100446	1	FITT2L-24P24Q000-000H001
12	110037	1	FITT2S-24P24P000-000H001
13	100565	1	FITT2S-24P24M000-000H001
14	400039	16	.75-10UNC x 2.75 Lg SHCS
15	100069	16	.75 Lock Washer
16	100654	1	Sandwich Shut-Off Valve (V-4)
17	400149	4	.375 Lock Washer
18	110544	1	Cartridge Cover (CC4)
19	110530	1	Cartridge Cover (CC1)
20	110546	1	Cartridge Cover (CC2)
21	110606	1	Cartridge Cover (CC3)
22	100650	4	.25-20UNC x 4.5 LG, SHCS
23	110624	2	Cartridge A (CA1-2)
24	110622	2	Cartridge B (CB1-2)
25	810519	1	Modified Spool Valve (V-2)
26	100845	2	FITT2P-04P000000-000S007
27	100990	2	Electrical Connector
30	140581	1	FITT2L-04P06M000-0000001
31	100149	2	HOSE025R02J004J004L01900
32	100145	4	FITT2L-04M04P000-0000001
33	100556	1	FITT2T-04M04M04J-0000001
34	110602	3	#111-O-Ring
35	140387	1	Orifice
36	100646	1	FITT2P-02P000000-000S007



**MODEL 815  
VIBRATORY  
DRIVER/EXTRACTOR**

# PARTS LIST

## CLAMP MANIFOLD ASSEMBLY

810449

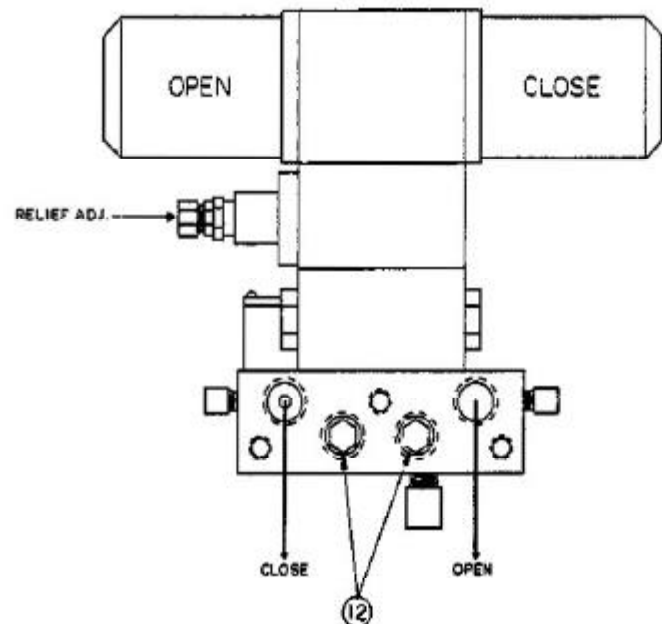
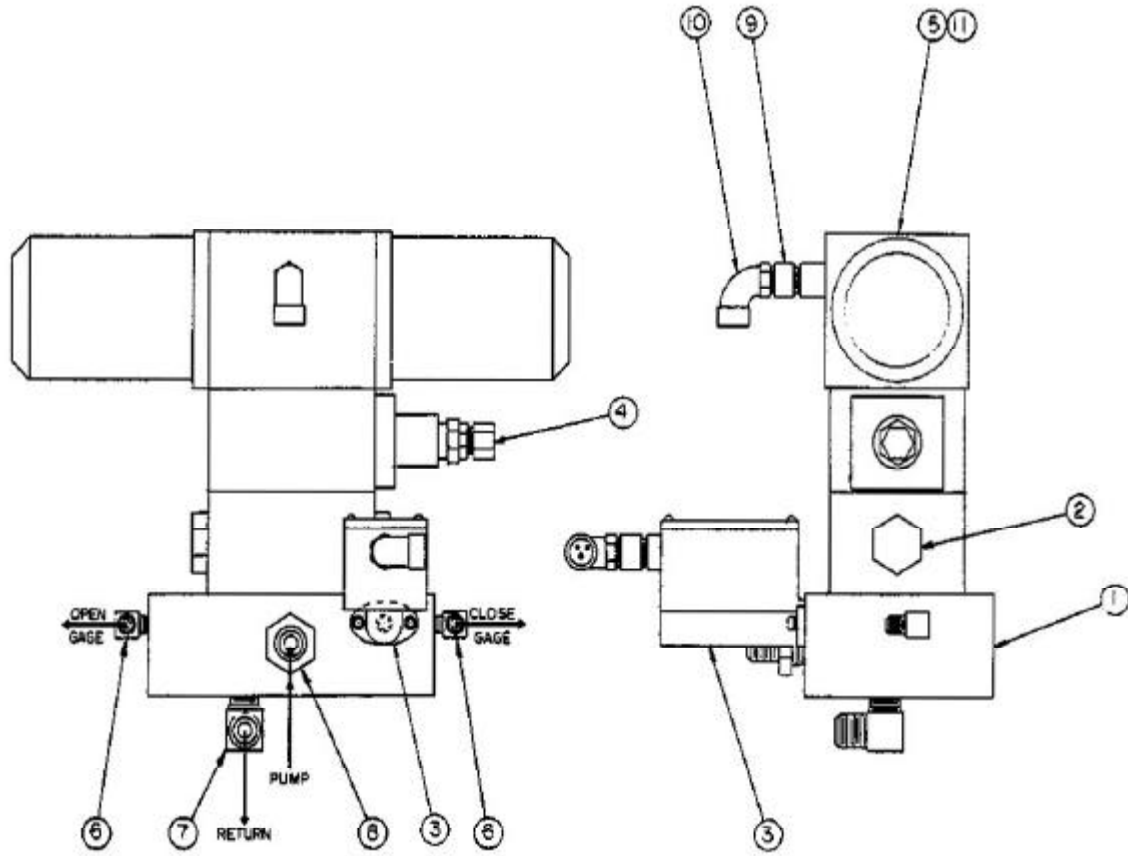



MODEL 815  
VIBRATORY  
DRIVER/EXTRACTOR

# PARTS LIST

CLAMP MANIFOLD ASSEMBLY

810449

<u>Item</u>	<u>Part Number</u>	<u>Qty.</u>	<u>Description</u>
1	110642	1	Manifold Block
2	110149	1	Check Valve (CV-5)
3	810033	1	Pressure Switch Asm. (PS-1)
4	100898	1	Relief Valve (RV2)
5	110147	1	4-Way Solenoid Valve (V1)
6	140539	2	FITT2L-04M02P000-0000001
7	110632	1	FITT2L-12M06P000-000H001
8	110630	1	FITT2S-08M06P000-000H001
9	110885	2	Conduit Adapter
10	110235	2	90 Deg. S/O Cord Adapter
11	100900	4	.25-20UNC x 6.0 Lg SHCS
12	400213	2	FITT2P-06P000000-000S007



MODEL 815  
VIBRATORY  
DRIVER/EXTRACTOR

# PARTS LIST

126B CLAMP ASSEMBLY (OPTIONAL)

800327

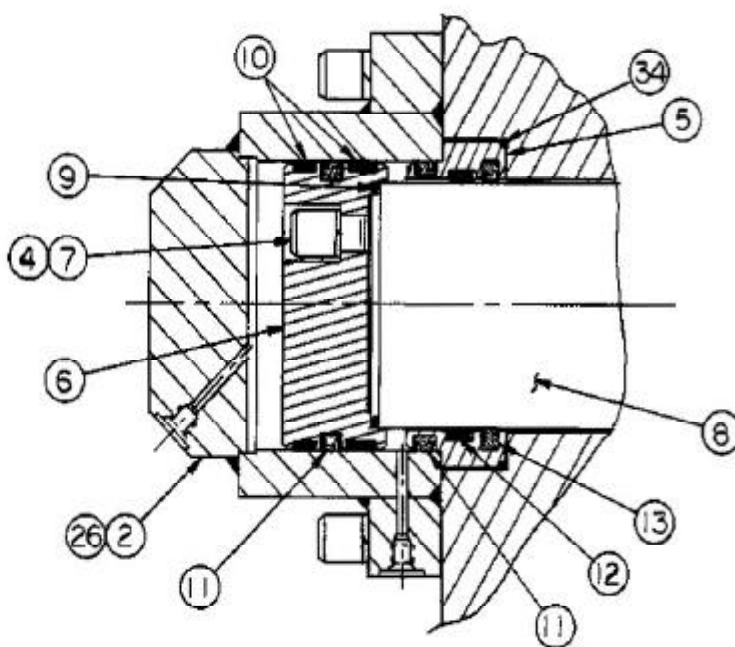
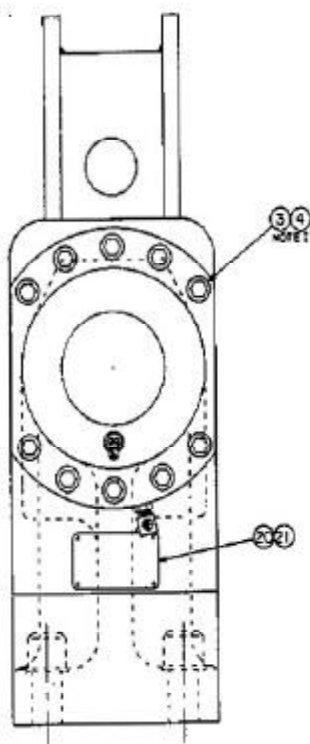
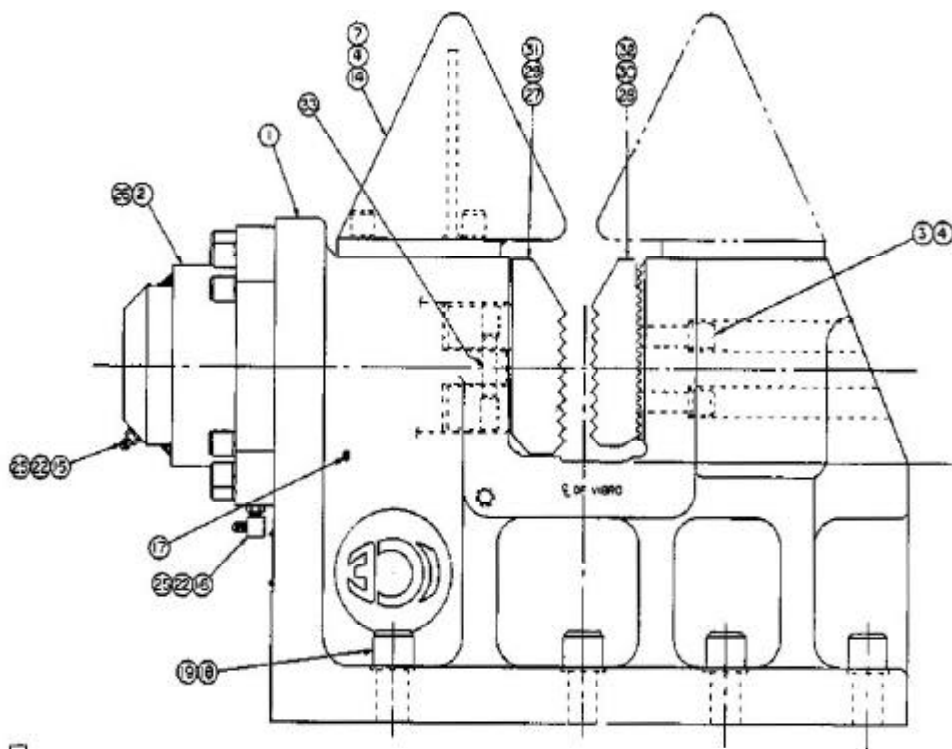

CYLINDER DETAIL

NOTE:  
1. TORQUE 1 SOCKET HEAD CAP SCREWS TO 540FT./LBS.



MODEL 815  
VIBRATORY  
DRIVER/EXTRACTOR

# PARTS LIST

126B CLAMP ASSEMBLY (OPTIONAL)

800327

<u>Item</u>	<u>Part Number</u>	<u>Qty.</u>	<u>Description</u>
1	810493	1	126B Clamp Body Asm.
2	810491	1	Welded Cylinder
3	100212	12	1-8UNC x 4.0 LG. SHCS
4	100209	19	1" Lock Washer
5	120567	1	Rod End Cap
6	120569	1	Piston
7	100213	7	1-8UNC x 2.50 LG. SHCS
8	120575	1	Cylinder Rod
9	120347	1	#261-O- Ring (Note)
10	120285	2	Piston Bearing (Note)
11	120283	2	Piston Seal (Note)
12	120555	1	Rod Bearing (Note)
13	120553	1	Rod Seal (Note)
14	100983	1	Pile Guide
15	100053	1	FITT2L-06M06R000-000H001
16	130057	1	FITT2L-06M06R000-000H001
17	100229	1	Grease Fitting
18	100193	8	1.5-6UNC x 5.0 LG. SHCS
19	100195	8	1.5 Lock Washer
20	100791	1	Clamp Label
21	130381	4	Rivet
22	100111	2	HOSE038R02J006J006L0875S
25	100230	2	FITT2P-06M000000-000T001
26	810515	1	126B Seal Kit
27	810495	1	Universal Movable Jaw
28	110515	1	Universal Fixed Jaw
29	810497	1	H-Beam Movable Jaw
30	110541	1	H-Beam Fixed Jaw
31	810499	1	DS-Movable Jaw
32	110419	1	DS-Fixed Jaw
33	130449	1	Spiral Roll Pin
34	120401	1	#269-O-Ring (Note)

Note; Included in 126B Seal Kit



MODEL 815  
VIBRATORY  
DRIVER/EXTRACTOR

# PARTS LIST

CLAMP EXTENSION - 8 FOOT (OPTIONAL)

8000063

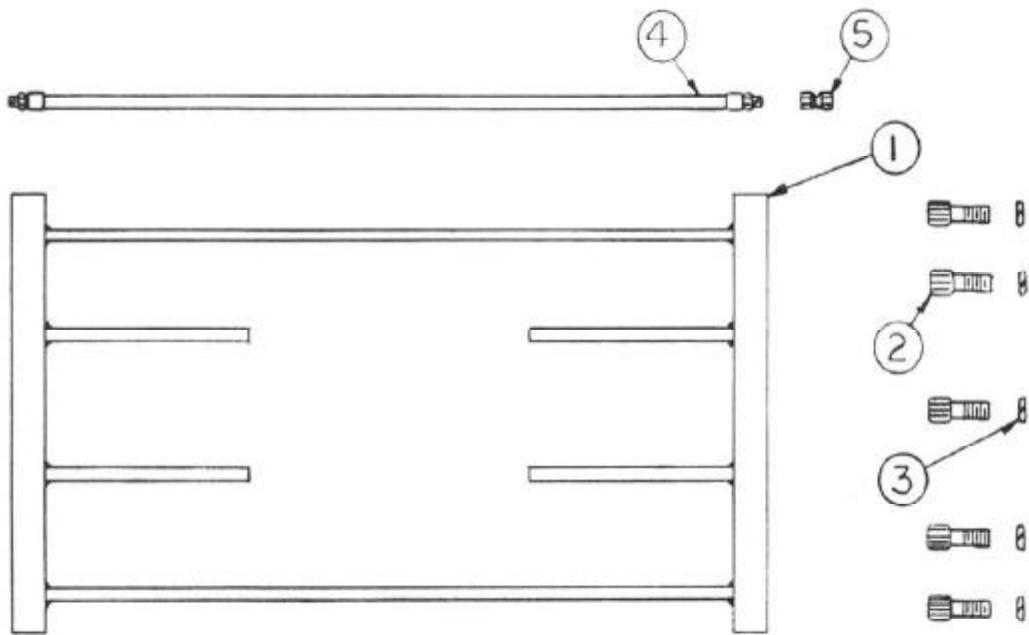

90 DEG. CLAMP ADAPTER (OPTIONAL)

800049

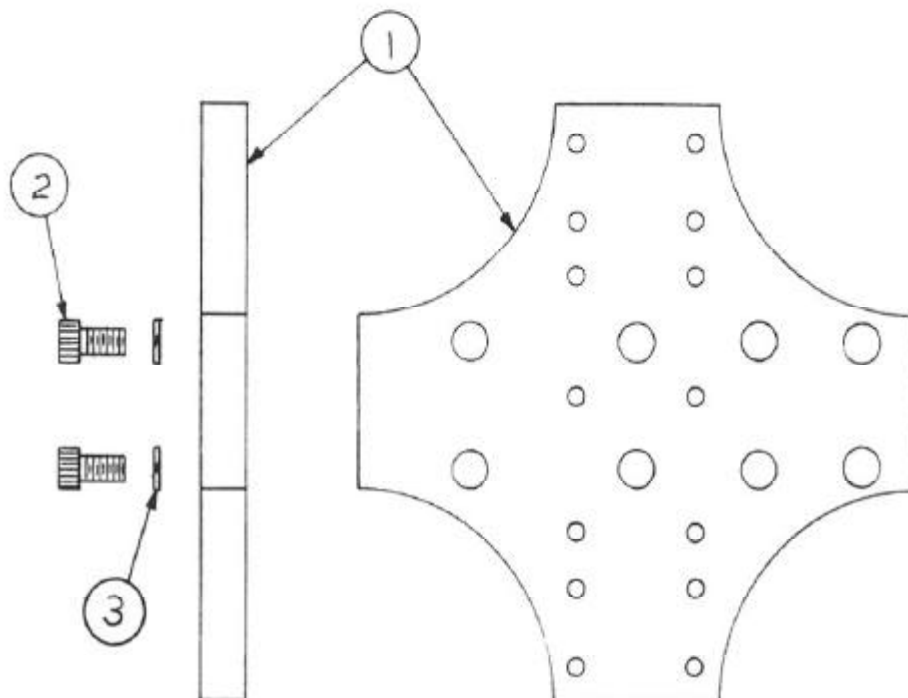



MODEL 815  
VIBRATORY  
DRIVER/EXTRACTOR

# PARTS LIST

CLAMP EXTENSION - 8 FOOT (OPTIONAL)

800063

<u>Item</u>	<u>Part Number</u>	<u>Qty.</u>	<u>Description</u>
1	810237	1	8' Extension
2	100193	10	1.50-6UNC x 5.00 LG. SHCS
3	100195	10	1.50 Lock Washer
4	120009	2	HOSE038R02J006J006L0960S
5	120081	2	FITT2S-06M06M000-000H001

90 Deg. CLAMP ADAPTER (OPTIONAL) 800049

<u>Item</u>	<u>Part Number</u>	<u>Qty.</u>	<u>Description</u>
1	120083	1	90 deg. Clamp Adapter
2	120077	8	1.50-6UNC x 3.50 LG SHCS
3	130219	8	1.50 Hi-Collar Lockwasher





**MODEL 815  
VIBRATORY  
DRIVER/EXTRACTOR**

# PARTS LIST

CAISSON BEAM - 7 FOOT (OPTIONAL)  
11 FOOT (OPTIONAL)

800045  
800163

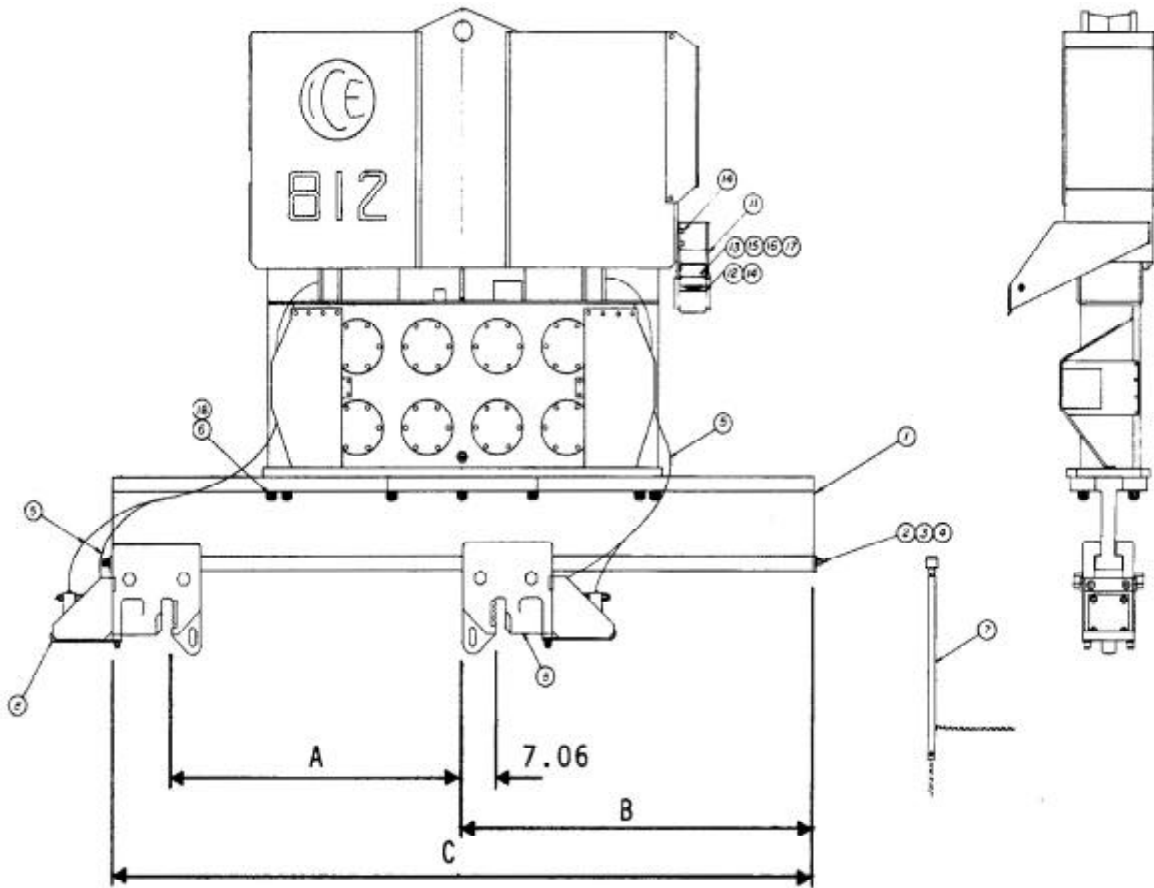

11' Caisson Beam (800163) - Shown  
7' Caisson Beam (800045) - Similar

	A	B	C
11' Beam (800163)	71.75	84	168
7' Beam (800045)	42	55	110



MODEL 815  
VIBRATORY  
DRIVER/EXTRACTOR

# PARTS LIST

CAISSON BEAM - 7 FOOT (OPTIONAL)

800045

<u>Item</u>	<u>Part Number</u>	<u>Qty.</u>	<u>Description</u>
1	120001	1	7' Caisson Beam
2	120011	2	Clamp Stop
3	400069	4	.75-10UNC x 2.00 Lg SHCS
4	100069	4	.75 Lock Washer
5	120009	4	HOSE038R02J006J006L0960S
6	120007	15	1.50-6UNC x 8.00 Lg SHCS
7	810173	1	Adjustment Tool
8	800047	2	#80 Caisson Clamp Asm. (Note)
11	110517	1	Caisson Hose Guide
12	110519	1	Hose Guide Rod
13	110521	1	Hose Guide Bracket
14	100575	6	.625-11UNC x 1.25 LG SHCS
15	100513	4	.5-13UNC x 1.50 LG SHCS
16	100485	4	.5-13UNC Hex Nut
17	100121	4	.5 Lock Washer
18	130219	15	1.50 Hi-Collar Lockwasher

CAISSON BEAM - 11 FOOT (OPTIONAL)

800163

<u>Item</u>	<u>Part Number</u>	<u>Qty</u>	<u>Description</u>
1	810251	1	11' Caisson Beam
2	120011	2	Clamp Stop
3	400069	4	.75-10UNC x 2.00 Lg SHCS
4	100069	1	.75 Lock Washer
5	120193	4	HOSE038R02J006J006L1320S
6	100193	14	1.50-6UNC x 5.00 Lg SHCS
7	810173	1	Adjustment Tool
8	800047	2	#80 Caisson Clamp Asm. (Note)
11	110517	1	Caisson Hose Guide
12	110519	1	Hose Guide Rod
13	110521	1	Hose Guide Bracket
14	100575	6	.625-10UNC x 1.25 Lg SHCS
15	100513	4	.5-13UNC x 1.50 Lg SHCS
16	100485	4	.5-13 Hex Nut
17	100121	4	.5 Lock Washer
18	100195	14	1.50 Lock Washer

Note: Not part of Caisson Beam Asm.



**MODEL 815  
VIBRATORY  
DRIVER/EXTRACTOR**

# PARTS LIST

**MODEL 80B CAISSON CLAMP (OPTIONAL)**

800047

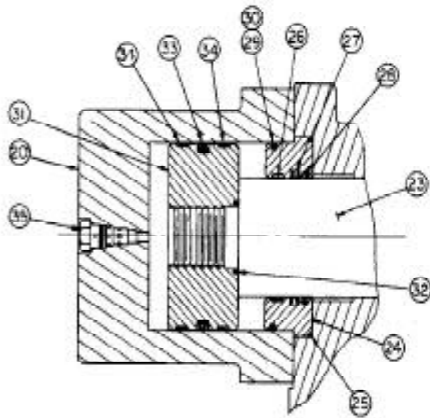

SECTION A-A

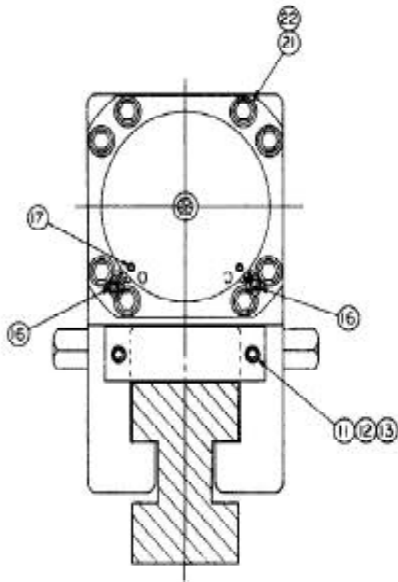
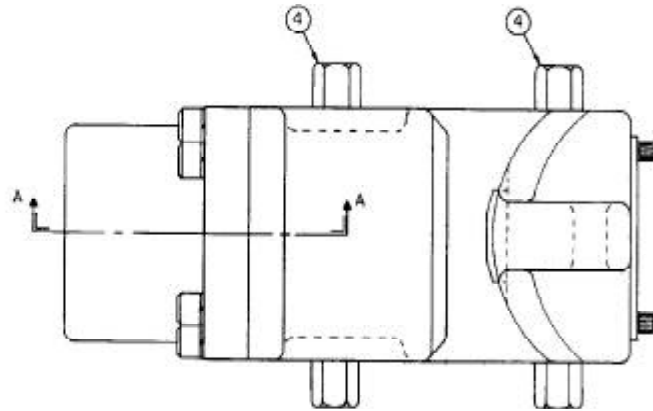

SECTION B-B

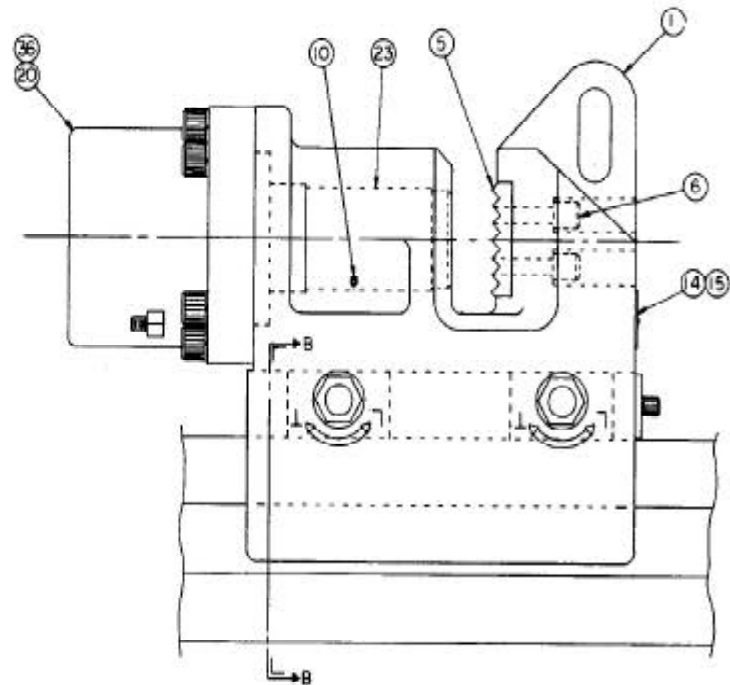

SECTION C-C

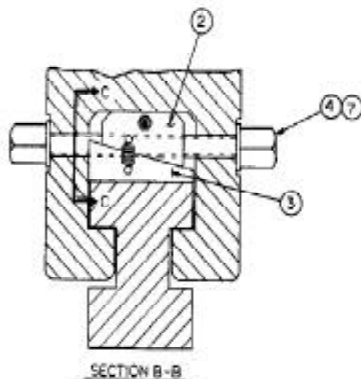



MODEL 815  
VIBRATORY  
DRIVER/EXTRACTOR

# PARTS LIST

MODEL 80B CAISSON CLAMP (OPTIONAL)

800047

<u>Item</u>	<u>Number</u>	<u>Qty.</u>	<u>Description</u>
1	810061	1	Clamp Body
2	120101	2	Wedge
3	120103	2	Lock
4	810109	2	Screw Asm.
5	120107	1	Fixed Jaw
6	400157	2	.625-11UNC x 2.75 Lg. SHCS
7	120111	4	Washer
8	120113	8	Drive Pin
9	120115	4	Spring
10	100229	3	Grease Fitting
11	120119	1	Wedge Guard
12	100119	2	.5-13UNC x 1.25 Lg. SHCS
13	100121	2	.5 Lockwasher
14	120159	1	Clamp Label
15	130381	4	Rivet
16	130057	2	FITT2L-06M06R000-000H001
17	100646	7	FITT2P-02P000000-000S007
20	120621	1	Cylinder
21	100212	8	1.0-8UNC x 4.00 Lg. SHCS
22	100209	8	1.0 Lockwasher
23	120631	1	Cylinder Rod
24	120623	1	Rod End Cap
25	120100	1	263-O-Ring (Note)
26	120627	1	Rod Bearing (Note)
27	120625	1	Rod Seal (Note)
28	120345	1	Rod Wiper (Note)
29	120347	1	#261-O-Ring (Note)
30	120349	1	#261-Back-up Ring (Note)
31	120313	1	Piston
32	120281	1	#140-O-Ring (Note)
33	120357	1	Piston Seal (Note)
34	120355	2	Piston Bearing (Note)
35	120629	1	Holding Valve
36	810611	1	80B Seal Kit

Note: Included in Model 80B Seal Kit.



MODEL 815  
VIBRATORY  
DRIVER/EXTRACTOR

# PARTS LIST

MODEL 127 Z-PILE CLAMP (OPTIONAL)

800041

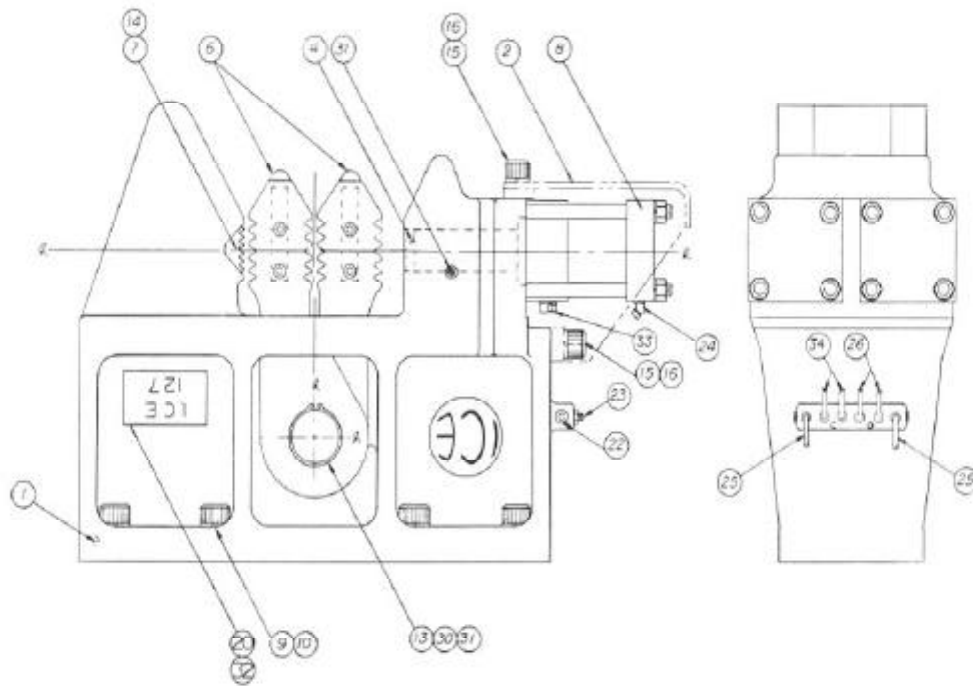
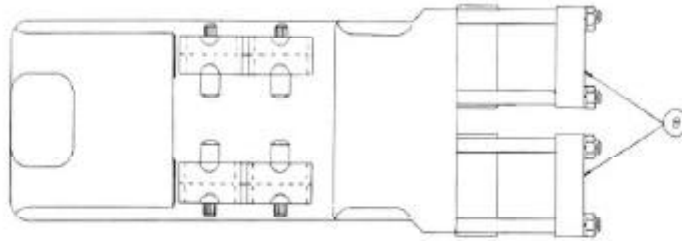



MODEL 815  
VIBRATORY  
DRIVER/EXTRACTOR

# PARTS LIST

MODEL 127 Z-PILE CLAMP (OPTIONAL)

800041

Item	Part Number	Qty.	Description
1	810059	1	Clamp Body
2	120137	1	Cylinder Guard
4	810197	2	Cylinder Rod Asm.
6	800139	1	Multi-Grip Inserts (Note)
7	120187	2	Jaw Insert
8	810175	2	Cylinder (CYL)
9	100193	8	1.5-8UNC x 5.00LG.SHCS
10	100195	8	1.5 Lock Washer
13	120155	1	Shaft
14	100163	2	.5-13UNC x 1.00 LG SHCS
15	100213	4	1-8UNC x 2.5 LG. SHCS
16	100209	4	1.0 Lock Washer
20	120181	1	Serial Number Name Plate
22	400213	2	FITT2P-06P000000-000S007
23	400203	6	FITT2S-06M06P000-000H001
24	100203	2	FITT2V-06M06R000-000H001
25	100111	2	HOSE038R02J006J006L0875S
26	120177	2	HOSE025R02J006J006L01400
30	120191	2	Retaining Ring
31	100229	4	Grease Fitting
32	130381	4	Rivet
33	130057	2	FITT2L-06M06R000-000H001
34	120179	2	HOSE025R0J006J0006L02000
35	100121	2	.5 Lock Washer

Note: Not part of 127 Z-Pile Clamp Asm.



MODEL 815  
VIBRATORY  
DRIVER/EXTRACTOR

# PARTS LIST

127 Z CYLINDER ASSEMBLY

810175

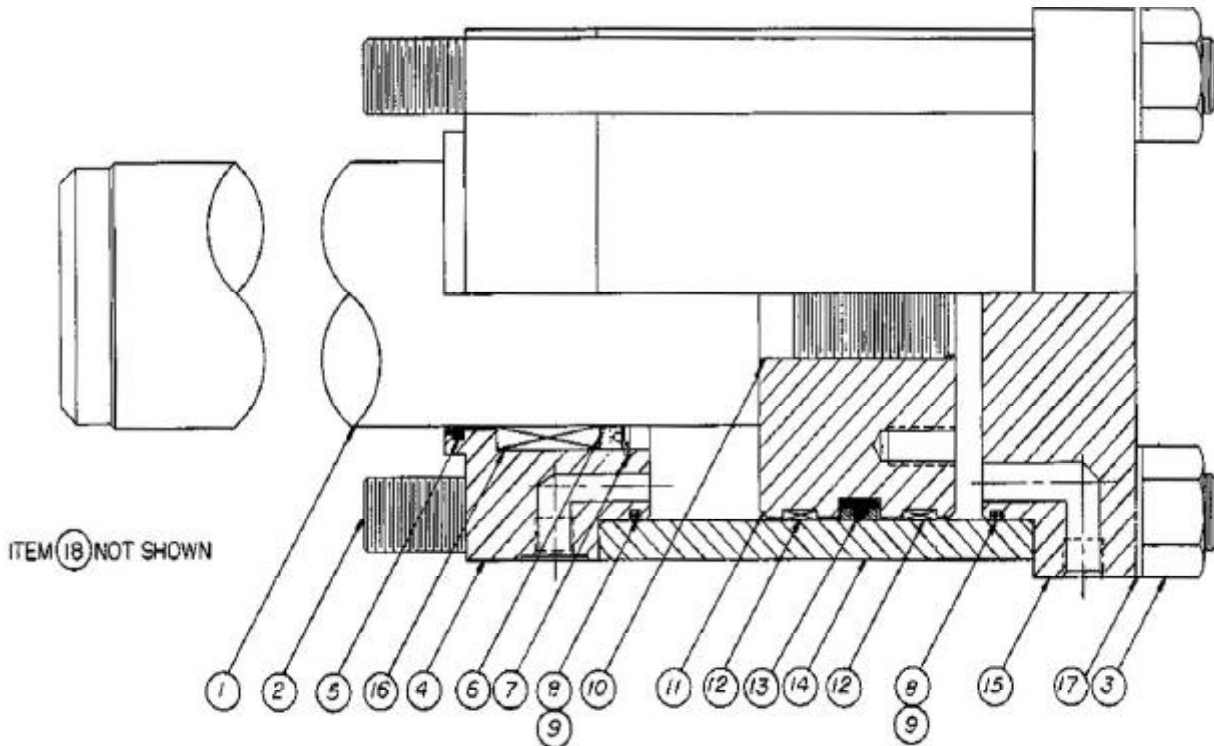

127 Z CYLINDER ASSEMBLY

810175

Item	Part Number	Qty	Description
1	120223	1	Cylinder Rod
2	120225	4	Tie Rod
3	120227	4	1.0-14UNC H.S. Hex Nut
4	120229	1	Rod End Cap
5	120231	1	Rod Wiper (Note)
6	120233	1	Rod Seal (Note)
7	120235	1	Retaining Ring
8	100159	2	#256-O-Ring (Note)
9	120237	2	#256-Back-Up Ring (Note)
10	120239	1	#132-O-Ring (Note)
11	120241	1	Piston
12	120243	2	Piston Bearing (Note)
13	120245	1	Piston Seal (Note)
14	120247	1	Cylinder Tube
15	120249	1	Piston End Cap
16	120251	1	Rod Bushing (Note)
17	120299	8	1.0 Flat Washer
18	810029	1	Z-Head Seal Kit

Note: Included in Z-Head Seal Kit.



MODEL 815  
VIBRATORY  
DRIVER/EXTRACTOR

# PARTS LIST

PENDANT EXTENSION CABLE - 50' (OPTIONAL)

800059

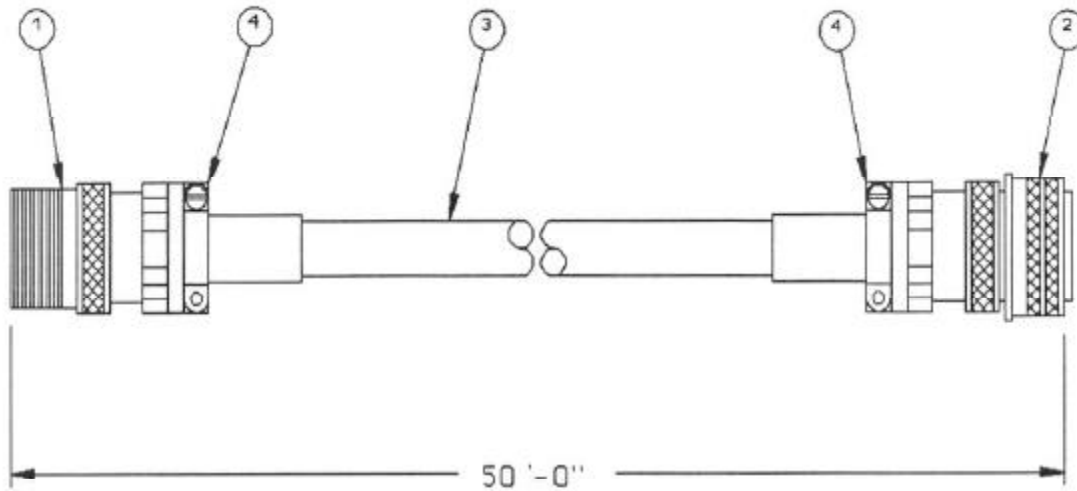

PENDANT EXTENSION CABLE - 50' (OPTIONAL)

Item	Part Number	Qty.	Description
1	100395	1	Amphenol Housing
	100763	1	Amphenol Insert
2	120169	1	Amphenol Housing
	100761	1	Amphenol Insert
3	100373	50	Extension Cable
4	100375	2	Strain Relief





MODEL 815  
VIBRATORY  
DRIVER/EXTRACTOR

# PARTS LIST

## VIII. ORDERING PARTS

### E. MISCELLANEOUS ACCESSORIES

#### 1. TOOLS

<u>Part Number</u>	<u>Qty.</u>	<u>Description</u>
100651	1	24-Volt Test Light
100653	1	Set of Allen Wrenches - Includes All Wrenches Shown Below:
100655		(1) 1/16" Allen Wrench - Long Arm
100691		(1) 5/64" Allen Wrench - Long Arm
100659		(1) 3/32" Allen Wrench - Long Arm
100661		(1) 7/64" Allen Wrench - Long Arm
100663		(1) 1/ 8" Allen Wrench - Long Arm
100665		(1) 9/64" Allen Wrench - Long Arm
100667		(1) 5/32" Allen Wrench - Long Arm
100669		(1) 3/16" Allen Wrench - Long Arm
100671		(1) 7/32" Allen Wrench - Long Arm
100673		(1) 1/ 4" Allen Wrench - Long Arm
100657		(1) 5/16" Allen Wrench - Long Arm
100675		(1) 3/ 8" Allen Wrench - Long Arm
100677		(1) 7/16" Allen Wrench - Long Arm
100679		(1) 1/ 2" Allen Wrench - Long Arm
100681		(1) 9/16" Allen Wrench - Long Arm
100683		(1) 5/ 8" Allen Wrench - Long Arm
100685		(1) 3/ 4" Allen Wrench - Long Arm
100687		(1) 7/ 8" Allen Wrench - Short Arm
100689		(1) 1" Allen Wrench - Short Arm

#### 2. BULK

<u>Part Number</u>	<u>Qty.</u>	<u>Description</u>
810013	5 GAL	Hydraulic Fluid (SUN 2105)
810011	5 GAL	Vibration Case Lubricant (SHC634)
100726	1 GAL	Coolant/Anti-Freeze
100298	1 GAL	I C E Green Paint
100299	1 GAL	Primer



MODEL 815  
VIBRATORY  
DRIVER/EXTRACTOR

# PARTS LIST

VIII. ORDERING PARTS

E. MISCELLANEOUS ACCESSORIES (Continued)

3. 815 HOSE GROUP KIT-INTERNAL

850053

Item	P/N	Qty.	Description	Page Ref.
5	110123	2	HOSE150PT4F024F024L0875S	VIII-13
9	110922	1	HOSE100R01F016H920L0680S	VIII-13
10	110988	1	HOSE100R01F016H920L0500S	VIII-13
13	100099	1	HOSE075R02F012F012L0880S	VIII-13
14	110994	1	HOSE100R10F016H920L0690S	VIII-13
15	110990	1	HOSE100R10F016H920L0530S	VIII-13
19	110329	1	HOSE050R01F008J908L0640S	VIII-13
20	110327	1	HOSE050R01F008J908L0481S	VIII-13
22	100111	2	HOSE038R02J006J006L0875S	VIII-13
23	110633	2	HOSE038R02J006J006L0370S	VIII-13
24	100108	2	HOSE038R02J006J006L0200S	VIII-13
31	100111	2	HOSE038R02J006J006L0875S	VIII-39

4. 570D HOSE GROUP KIT-INTERNAL

850111

Item	P/N	Qty.	Description	Page Ref.
14	110395	1	HOSE025R01J004J004L04800	VIII-24
76	400215	1	HOSE100R01P016P016L08400	VIII-25
81	100941	1	HOSE075R01J012J012L04400	VIII-25
87	130201	1	HOSE075R01J012J012L04000	VIII-25
92	110467	1	HOSE150R01J024F924L16600	VIII-25
93	110469	1	HOSE150R01J024F924L14300	VIII-25
138	110831	1	HOSE100R01P016J016L07000	VIII-26
140	110470	1	HOSE050PT4J008J008L03500	VIII-26
275	100228	1	HOSE038R02J006J006L06100	VIII-28
277	110588	1	HOSE150R01F924J024L02050	VIII-28
278	110780	1	HOSE150R01F924J024L04900	VIII-28
279	110586	1	HOSE150R01J024J024L12900	VIII-28
280	110019	1	HOSE075R01J012J012L04800	VIII-28
289	110480	1	HOSE100PT4F016F920L03900	VIII-28
290	110478	1	HOSE100PT4F016F920L04000	VIII-28
291	110476	1	HOSE100PT4F016F920L04100	VIII-28
292	110474	1	HOSE100PT4F016F920L04350	VIII-28
293	110680	1	HOSE019R01J004J004L40000	VIII-28
294	130205	3	HOSE019R01J004J004L09000	VIII-28
31	100149	2	HOSE025R02J004J004L01900	VIII-33



MODEL 815  
VIBRATORY  
DRIVER/EXTRACTOR

# PARTS LIST

VIII. ORDERING PARTS

E. MISCELLANEOUS ACCESSORIES (CONTINUED)

5. 815/570D O-RING KIT 850109

<u>P/N</u>	<u>Qty.</u>	<u>Description</u>
110602	3	#111-O-Ring
110197	2	#159-O-Ring
110195	2	#163-O-Ring
100107	2	#210-O-Ring
100097	4	#214-O-Ring
100091	8	#219-O-Ring
100037	8	#222-O-Ring
110119	10	#225-O-Ring
400379	2	#232-O-Ring
100167	16	#266-O-Ring

6. CYLINDER SEAL KITS

MODEL 126B CLAMP CYLINDER 800327 Refer to page VIII-37

<u>Item</u>	<u>P/N</u>	<u>Qty.</u>	<u>Description</u>
9	120347	1	#261-O-Ring
10	120285	2	Piston Bearing
11	120283	2	Piston Seal
12	120555	1	Rod Bearing
13	120553	1	Rod Seal
34	120401	1	#269-O-Ring

MODEL 80B CLAMP CYLINDER 800047 Refer to page VIII-43

<u>Item</u>	<u>P/N</u>	<u>Qty.</u>	<u>Description</u>
25	120100	1	#263-O-Ring
26	120627	1	Rod Bearing
27	120625	1	Rod Seal
28	120345	1	Rod Wiper
29	120347	2	#261-O-Ring
30	120349	2	#261-Back-up Ring
32	120281	1	#140-O-Ring
33	120357	1	Piston Seal
34	120355	2	Piston Bearing



MODEL 815  
VIBRATORY  
DRIVER/EXTRACTOR

# PARTS LIST

VIII. ORDERING PARTS

F. RECOMMENDED SPARE PARTS

VIBRATION SUPPRESSOR 800057 Refer to page VIII-6

Item	P/N	Qty.	Description
2	100003	2	Elastomer
20	110113	1	Filter Element
21	110119	2	#225-O-Ring
55	110215	1	#239-O-Ring
56	110217	1	#239-Back-Up Washer
79	100097	2	#214-O-Ring

VIBRATION CASE 810085 Refer to page VIII-10

Item	P/N	Qty.	Description
13	110195	2	#163-O-Ring (Bearing)
15	110197	2	#159-O-Ring (Motor)
17	100167	4	#266-O-Ring
--	110605	2	Motor Shaft Seal
26	100185	1	Sight Gage

HOSE ASSEMBLIES-INTERCONNECTING 800053 Refer to page VIII-14

Item	P/N	Qty.	Description
4	110141	1	HOSE150PT4P024P024L60000
9	110970	1	HOSE200R02J032J032L60000
13	100241	1	HOSE075R02P012P012L62000
17	100247	2	HOSE038R02P008P008L62000

POWER UNIT - INTERNAL 800127 Refer to page VIII-22

Item	P/N	Qty.	Description
90	110119	4	#225-O-Ring
99	810117	4	Filter Element
140	110470	1	HOSE050R09J008J908L03500
144	100037	4	#222-O-Ring
289	110480	1	HOSE100PT4F016F920L03900
290	110478	1	HOSE100PT4F016F920L04000
291	110476	1	HOSE100PT4F016F920L04100
292	110474	1	HOSE100PT4F016F920L04350
---	110423	1	Air Cleaner Element



MODEL 815  
VIBRATORY  
DRIVER/EXTRACTOR

# PARTS LIST

## VIII. ORDERING PARTS

### F. RECOMMENDED SPARE PARTS (CONTINUED)

DISTRIBUTION BLOCK                      810087                      Refer to page VIII-12

<u>Item</u>	<u>P/N</u>	<u>Qty</u>	<u>Description</u>
4	110119	4	#225-O-Ring
8	100091	4	#219-O-Ring
12	100097	2	#214-O-Ring
18	100107	2	#210-O-Ring

MODEL 126B CLAMP                      800327                      Refer to page VIII-36

<u>Item</u>	<u>P/N</u>	<u>Qty.</u>	<u>Description</u>
15	100053	1	FITT2S-06M06R000-000H001
16	130057	1	FITT2L-06M06R000-0000001
18	100193	8	1.5-8UNC x 5.00 LG. SHCS
19	100195	8	1.5 Lock Washer
22	100111	2	HOSE038R02J006J00620875S
26	810515	1	126B Seal Kit
27	810495	1	Universal Movable Jaw
28	110515	1	Universal Fixed Jaw
29	810497	1	H-Beam Movable Jaw
30	110541	1	H-Beam Fixed Jaw
31	810499	1	DS-Movable Jaw
32	110419	1	DS-Fixed Jaw
33	130449	1	Spiral Roll Pin



MODEL 815  
VIBRATORY  
DRIVER/EXTRACTOR

# PARTS LIST

## VIII. ORDERING PARTS

### F. RECOMMENDED SPARE PARTS (CONTINUED)

MODEL 127 Z-PILE CLAMP      800041      Refer to page VIII-44

<u>Item</u>	<u>P/N</u>	<u>Qty.</u>	<u>Description</u>
7	120187	2	Jaw Insert
9	100193	8	1.50-6UNC x 5.00 LG SHCS (Head Bolts)
10	100195	8	1.50 Lock Washer
23	400203	2	FITT2S-06M06P000-000H001
24	100203	2	FITT2V-06M06R000-000H001
25	100111	1	HOSE038R02J006J006L0875S
28	120177	1	HOSE025R02J006J006L01400
33	130057	2	FITT2L-06M06R000-000H001
34	120179	1	HOSE025R02J006J006L02000
--	810029	2	Clamp Cylinder Seal Kit

MODEL 80 CAISSON CLAMP      800047      Refer to page VIII-42

<u>Item</u>	<u>P/N</u>	<u>Qty.</u>	<u>Description</u>
4	810109	1	Screw Assembly
5	120107	1	Fixed Jaw
6	400157	2	.625-10UNC x 2.75 LG SHCS
16	130057	2	FITT2L-06M06R000-000H001
35	120629	1	Holding Valve
36	810811	1	Seal Kit



# PARTS LIST

## G. CYLINDER INSTALLATION INSTRUCTIONS AND ASSEMBLY PROCEDURES

1. Assemble cylinder to clamp using grease and extreme care to prevent damage to O-rings.
2. Lubricate the tie rod threads with "NEVER SEIZE" and install hardened washers.
3. Install tie rod nuts "finger tight" against the cylinder head.
4. Torque the rod nuts in the sequence shown in Fig.1 per each of the four steps shown in the table. (Ft/Lbs.)
5. Scribe a line on a convenient point of the nut and cylinder head as shown in Fig. 2.
6. Turn the nuts an additional number of 1/12th turns as shown in the last column of the table.
7. Tighten the tie rod nuts in the sequence shown in Fig.1 with a 2/12ths maximum turn per each sequence.

CLAMP MODEL	BORE	TORQUE PER FIG.1 SEQUENCE FT/LBS.				TURNS IN 12ths
		STEP 1	STEP 2	STEP 3	STEP 4	
125/126	8"	30	60	125	250	5
216	7"	25	50	100	200	5
127	6"	20	80	250	480	0
80	7"	25	50	100	200	5
254	12"	30	60	125	250	7

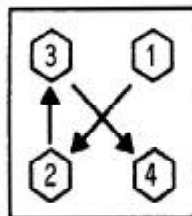

Fig. 1

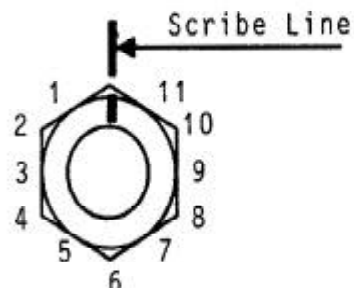

Fig. 2



MODEL 815  
VIBRATORY  
DRIVER/EXTRACTOR

# PARTS LIST

## H. RECOMMENDED TIGHTENING TORQUE

Nominal Screw Size	Nominal Socket Size	Tightening Torque Ft/lbs.	Nominal Screw Size	Nominal Socket Size	Tightening Torque Ft/lbs.
#10-24	5/32	6 Ft/lbs.	#10-32	5/32	6 Ft/lbs.
1/4-20	3/16	13 Ft/lbs.	1/4-28	3/16	15 Ft/lbs.
5/16-18	1/4	27 Ft/lbs.	5/16-24	1/4	30 Ft/lbs.
3/8-16	5/16	48 Ft/lbs.	3/8-24	5/16	55 Ft/lbs.
7/16-14	3/8	77 Ft/lbs.	7/16-20	3/8	86 Ft/lbs.
1/2-13	3/8	119 Ft/lbs.	1/2-20	3/8	133 Ft/lbs.
5/8-11	1/2	234 Ft/lbs.	5/8-18	1/2	267 Ft/lbs.
3/4-10	5/8	417 Ft/lbs.	3/4-16	5/8	467 Ft/lbs.
7/8-9	3/4	676 Ft/lbs.	7/8-14	3/4	742 Ft/lbs.
1-8	3/4	1,009 Ft/lbs.	1-12	3/4	1,126 Ft/lbs.
1-1/4-7	7/8	1,600 Ft/lbs.	1-1/4-12	7/8	1,800 Ft/lbs.
1-1/2-6	1	2,800 Ft/lbs.	1-1/2-12	1	3,000 Ft/lbs.

NOTE: These values are for Socket head cap screws only. Button heads, Flat heads and Set screws have different values. Check the Allen Hand Book for correct torque specifications.