



**MODEL 416  
VIBRATORY  
DRIVER/EXTRACTOR**

OPERATING AND MAINTENANCE MANUAL

## **ICE MODEL 416**

VIBRATORY PILE DRIVER/EXTRACTOR

WITH MODEL 250 POWER PACK

Serial Numbers: 182786 and  
182790 & above

OM-416/250-0582



**INTERNATIONAL  
CONSTRUCTION  
EQUIPMENT**

301 WAREHOUSE DR. MATTHEWS, N.C. 28105 704 821-7681



**MODEL 416  
VIBRATORY  
DRIVER/EXTRACTOR**

**PREFACE**

This manual was prepared to acquaint the owner, operator and serviceman with the operation and maintenance of the vibratory driver/extractor. We suggest that this manual be carefully studied before operating or undertaking any maintenance work on the unit.

This manual is organized into two major categories.

The first category is for routine OPERATING INSTRUCTIONS of the unit and includes a GENERAL DESCRIPTION section which presents a basic explanation of the driver/extractor and some of its specifications. The MAINTENANCE AND ADJUSTMENT section should be referred to periodically for normal servicing of equipment. All machines and equipment require systematic, periodic inspection and maintenance if they are to perform satisfactorily over a long period of time. The driver/extractor is primarily a vibrating machine and if not given the best of care, or if improperly used and maintained, it is self destructive. Therefore, the unit should receive at least the same care and maintenance as other high quality construction equipment.

The second category is for parts reordering and it includes both a PARTS LIST and a pictorial drawing of the assembly for easier determination of the required part. Refer to the ORDERING PARTS section of the PARTS LIST for more specific procedures regarding parts ordering. Adherence of the listed procedures will insure receipt of the required part (s) with the minimal amount of delay or error.



**MODEL 416  
VIBRATORY  
DRIVER/EXTRACTOR**

**WARRANTY**

**INTERNATIONAL CONSTRUCTION EQUIPMENT STANDARD WARRANTY**

International Construction Equipment (ICE) warrants new products sold by it to be free from defects in material or workmanship for a period of 90 days after date of delivery to the first user and subject to the following conditions:

ICE's obligation and liability under this WARRANTY is expressly limited to repairing or replacing at ICE's option, any parts which appear to ICE upon inspection to have been defective in material or workmanship. Such parts shall be provided at no cost to the user, at the business establishment of ICE or the authorized ICE distributor of the product during regular working hours. This WARRANTY shall not apply to component parts or accessories of products not manufactured by ICE and which carry the warranty of the manufacturer thereof, or to normal maintenance (such as engine tune-up) or to normal maintenance parts (such as oil filters). Replacement or repair parts installed in the product covered by this WARRANTY are warranted only for the remainder of the warranty as if such parts were original components of said product. ICE COMPANY MAKES NO OTHER WARRANTY, EXPRESS OR IMPLIED, AND MAKES NO WARRANTY OF MERCHANTABILITY OF FITNESS FOR ANY PARTICULAR PURPOSE.

ICE's obligation under this WARRANTY shall not include any transportation charges, costs of installation, duty, taxes or any other charges whatsoever, or any liability for direct, indirect, incidental, or consequential damage or delay. If requested by ICE, products or parts for which a warranty claim is made are to be returned transportation prepaid to ICE. Any improper use, including operation after discovery of defective or worn parts, operation beyond rated capacity, substitution of parts not approved by ICE or any alteration or repair by others in such manner as in ICE's judgement affects the product materially and adversely, shall void this WARRANTY.

NO EMPLOYEE OR REPRESENTATIVE IS AUTHORIZED TO CHANGE THIS WARRANTY IN ANY WAY OR GRANT ANY OTHER WARRANTY UNLESS SUCH CHANGE IS MADE IN WRITING AND SIGNED BY AN OFFICER OF ICE.



**MODEL 416  
VIBRATORY  
DRIVER/EXTRACTOR**

**TABLE OF CONTENTS**

**OPERATING INSTRUCTIONS**

<b><u>I. GENERAL DESCRIPTION</u></b>	<b><u>PAGE</u></b>
A. General	I- 1
B. Vibrator	I- 2
C. Hydraulic Clamp Head	I- 2
D. Power Unit	I- 2
E. Remote-Control Pendant	I- 3
F. Specifications	I- 3
<b><u>II. PREPARATION FOR OPERATION</u></b>	
A. General	II- 1
B. Safety Precautions	II- 1
C. Rigging of Vibrator	II- 2
D. Connection of Hydraulic Clamp	II- 2
E. Connection of Hydraulic Hoses	II- 3
F. Bleeding Hydraulic Clamp Hoses	II- 5
G. Filling Vibrator Pressure Hose	II- 5
<b><u>III. OPERATING INSTRUCTIONS</u></b>	
A. Completion of Set-Up and Maintenance	III- 1
B. Control Panel	III- 1
C. Starting and Warming Up Engine	III- 2
D. Warming Hydraulic Fluid	III- 2
E. Operation of Remote-Control Pendant	III- 3
F. Changing Frequency	III- 4
G. Shutdown	III- 5
H. Extracting Line Pull Load Indicator	III- 5
<b><u>IV. MAINTENANCE AND ADJUSTMENTS</u></b>	
A. General	IV- 1
B. Daily	IV- 1
C. 100 Hours, 150 Hours and Other	IV- 3
D. Annually	IV- 3
E. Severe Conditions	IV- 3
F. Lubrication	IV- 4
G. Capacities	IV- 7
H. Draining and Filling Hydraulic Fluid Reservoir	IV- 7
I. Cleaning Hydraulic Pick-Up Filter	IV- 8
J. Changing Hydraulic Return Filter Element	IV- 8
K. Changing Hydraulic Vibrator Filter Element	IV- 9
L. Bolt Torque Information	IV- 9



**MODEL 416  
VIBRATORY  
DRIVER/EXTRACTOR**

TABLE OF CONTENTS

OPERATING INSTRUCTIONS (CONTINUED)

	<u>PAGE</u>
V. <u>HYDRAULIC CIRCUITRY</u>	
A. Hydraulic Clamp	V- 1
B. Vibrator Drive	V- 1
C. Other	V- 3
Hydraulic Schematic	V- 4
D. Hydraulic Components List	V- 5
VI. <u>ELECTRICAL CIRCUITRY</u>	
A. Diesel Engine	VI- 1
B. Hydraulic Clamp	VI- 2
C. Vibrator	VI- 2
D. Other	VI- 2
Electrical Schematic	VI- 3
E. Electrical Components List	VI- 4
Electrical Diagram	VI- 5
	<u>PARTS LIST</u>
VII. <u>GENERAL DATA</u>	
A. Abbreviations	VII- 1
B. Screws and Bolts	VII- 1
C. Serial Number Locations	VII- 2
VIII. <u>ORDERING PARTS</u>	
A. Procedure	VIII- 1
B. Fitting Description Key	VIII- 2
Fitting Style Selector Chart - SC1	VIII- 3
C. Hose Description Code	VIII- 4
D. Parts Identification	VIII- 5
Parts Lists and Drawings	VIII-6 thru VIII-43
E. Miscellaneous Accessories	VIII-44
F. Recommended Spare Parts	VIII-48



MODEL 416  
VIBRATORY  
DRIVER/EXTRACTOR

# OPERATING INSTRUCTIONS

## I. GENERAL DESCRIPTION

### A. GENERAL

The ICE Model 416 is a low-frequency vibratory pile driver/extractor designed to drive and extract sheet, pipe, timber and concrete piles, caisson pipe and H, I and wide-flange beams.

The Model 416 operates in a frequency range of 400 to 1500 vibrations per minute to provide maximum pile penetration rates in a wide variety of soils. The unit has an eccentric moment of 1800 inch-pounds and operates with an amplitude of 1/4 to 1 inch.

The vibratory driver unit consists of two major components. (1) The vibrator with attached clamp and (2) the power unit with remote control pendant.

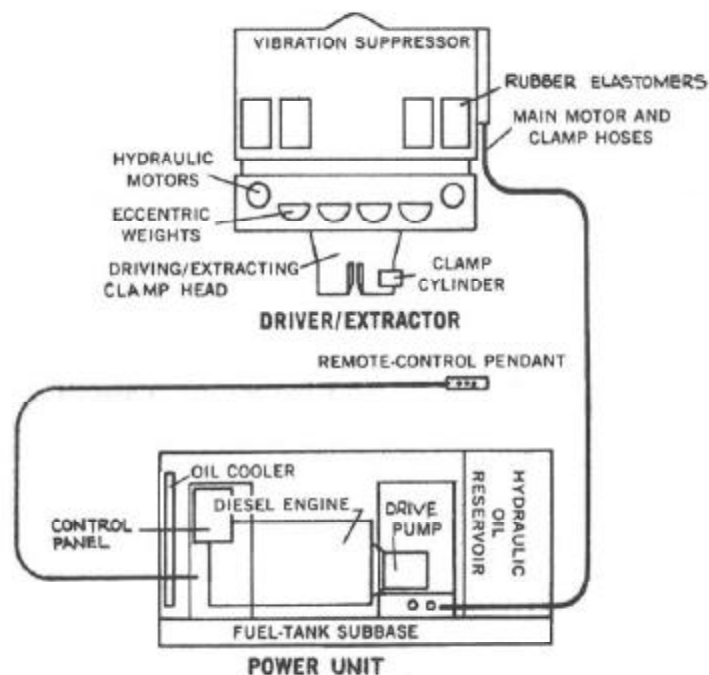



MODEL 416  
VIBRATORY  
DRIVER/EXTRACTOR

# OPERATING INSTRUCTIONS

## I. GENERAL DESCRIPTION

### B. VIBRATOR

The vibrator consists of two major components. (1) The vibration case and (2) the vibration suppressor.

The vibration case contains four eccentric weights which rotate in a vertical plane to create vibration. The eccentric weights are driven by two hydraulic motors mounted on the vibration case. The two motors and four eccentrics are all gear connected to maintain proper synchronization. The eccentric and motor shafts are mounted in heavy-duty cylindrical roller bearings. Lubrication is provided by a splash system activated by the rotating eccentric and gears.

The vibration suppressor contains eight rubber elastomers to isolate the vibration case from the crane line. The suppressor is designed for a maximum line pull of 40 tons during extractions.

### C. HYDRAULIC CLAMP HEAD

The hydraulic clamp contains two gripping jaws; one fixed and one moveable. A large hydraulic cylinder operates the moveable jaw with 100 tons of force to grip the pile. Clamping and unclamping occurs in a few seconds.

### D. POWER UNIT

The Model 250 power unit for the Model 416 vibrator is powered by a Caterpillar 3208 engine. The engine develops 250 HP at 2600 RPM.

The totally enclosed power unit is mounted on a skid-type fuel tank sub-base. Control panels at the side of the unit contain all operating gages and controls. A common reservoir supplies hydraulic fluid to two separate hydraulic pumps - one for the vibrator motors and one for the hydraulic clamp.

Three hydraulic hose lines, 150 feet in length, connect the power unit to the hydraulic motors in the vibrator. Two other hydraulic hose lines run from the power unit to the hydraulic clamp.



**MODEL 416  
VIBRATORY  
DRIVER/EXTRACTOR**

**OPERATING  
INSTRUCTIONS**

**I. GENERAL DESCRIPTION**

**E. REMOTE-CONTROL PENDANT**

The vibrator is operated by a hand-held, remote-control pendant. The pendant has two, two-way switches and an indicator light. One switch (VIBRATOR SWITCH) starts and stops vibration. The other switch (CLAMP SWITCH) closes and opens the hydraulic clamp. The light indicates that adequate clamping pressure exists for vibration to begin.

**F. SPECIFICATIONS**

1. Constant improvement and engineering progress make it necessary that we reserve the right to make specification changes without notice.

**2. MODEL 416 VIBRATOR  
(with hydraulic clamp)**

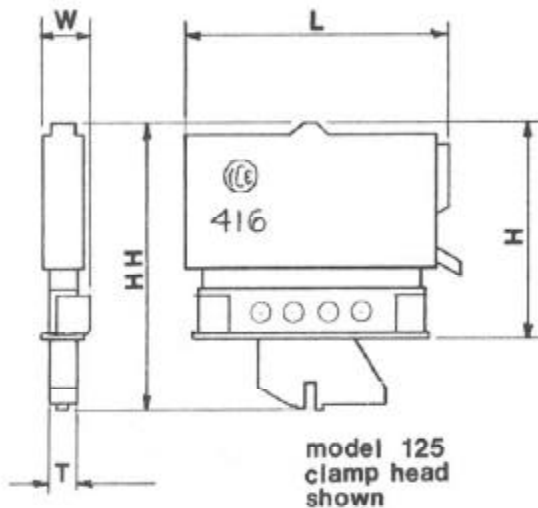

Type.....Hydraulic  
Eccentric Moment.....1800 In-lbs.  
Frequency.....400-1500 VPM  
Amplitude.....1/4"-1 in.  
Pile Clamping Force.....100 Tons  
Max. Line Pull for  
Extraction.....40 Tons  
Suspended Weight  
with 125 Clamp.....12,600 lbs.  
Length (L).....96 inches  
Width (W).....22 inches  
Throat Width (T).....12 inches  
Height with Clamp (HH) ...105 inches  
Height without Clamp (H)...76 inches

**3. MODEL 250 POWER UNIT**

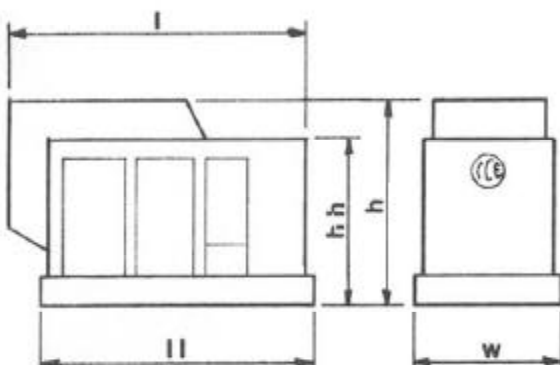

Type.....Hydraulic  
Engine.....CAT 3208T  
Horsepower (2600 RPM)....250  
Weight.....9,300 lbs.  
Length (ll) .....108 inches  
Width (w).....60 inches  
Height (h).....80 inches  
Length (l).....126 inches  
Height (hh).....62 inches





MODEL 416  
VIBRATORY  
DRIVER/EXTRACTOR

# OPERATING INSTRUCTIONS

## II. PREPARATION FOR OPERATION

### A. GENERAL

When unloading and unpacking the vibratory driver, use extreme care. For your protection, make a thorough inspection of the unit immediately on delivery. In case of any damage or shortage, notify the transit agent at once and have the delivering carrier make a notation on the freight bill.

### B. SAFETY PRECAUTIONS

Safety is basically common sense. There are standard safety rules, but each situation has its own peculiarities which can not always be covered by rules. Therefore, your experience and common sense will be your best guide to safety. Be ever watchful for safety hazards and correct deficiencies promptly.

Use the following safety precautions as a general guide to safe operations:

1. When operating in a closed area, pipe exhaust fumes outside. Continued breathing of exhaust fumes may be fatal.
2. When servicing batteries, do not smoke or use an open flame in the vicinity. Batteries generate explosive gas during charging. There must be proper ventilation when charging batteries.
3. When filling fuel tank, do not smoke or use open flame in the vicinity.
4. Be extremely careful when using a carbon tetrachloride fire extinguisher in a closed area as it produces toxic vapor. Provide adequate ventilation before entering a closed area where carbon tetrachloride has been used.
5. Never adjust or repair the unit while it is in operation.



MODEL 416  
VIBRATORY  
DRIVER/EXTRACTOR

# OPERATING INSTRUCTIONS

## II. PREPARATION FOR OPERATION

### B. SAFETY PRECAUTIONS (CONTINUED)

6. Never operate the diesel engine with the governor linkage disconnected. Human reactions are not fast enough to control the fuel rack.
7. Remove all tools and electrical cords before starting.
8. Store oily rags in containers.
9. Never store flammable liquids near the engine.

REMEMBER, SAFETY IS EVERYONE'S BUSINESS.

### C. RIGGING OF VIBRATOR

A steel wire rope sling must be connected to the lifting pin of the vibration suppressor. The required strength of this sling depends on the capacity of the crane and the work to be carried out. A safety factor of five is recommended. Several turns of a smaller diameter cable will usually last longer than one turn of a larger diameter cable.

### D. CONNECTION OF HYDRAULIC CLAMP

The vibrator is usually shipped with the hydraulic clamp already attached.

If the clamp is not attached, it will be necessary to attach it to the bottom of the vibrator. When the vibrator is connected to the crane line, lift the vibrator so that the hydraulic clamp can be bolted to the bottom of the vibration case. All eight bolts must be in place. Place a pipe over the end of the Allen wrench to provide a six-foot lever arm. Have two men tighten each bolt.

For caisson work, the caisson beam must be attached to the bottom of the vibrator. Then slide the clamps into position on the caisson beam.



MODEL 416  
VIBRATORY  
DRIVER/EXTRACTOR

# OPERATING INSTRUCTIONS

## II. PREPARATION FOR OPERATION

### E. CONNECTION OF HYDRAULIC HOSES

#### 1. Connection of hoses at power unit.

- a. The vibrator and hydraulic clamp are connected to the power unit by five hydraulic hose lines (Fig. 1).

CAUTION: The power unit must be shut down during connection of the hydraulic hoses.

- b. The hoses connect to the power unit with quick-disconnect couplers. The hose couplers are arranged to insure correct connection at the power unit.
- c. Clean couplers with a lint-free cloth before making connections.
- d. Make sure that the couplers are fully run up. They should be fully hand tight. Do not use wrenches to tighten.

NOTE: Open-clamp line attaches behind close-clamp line at vibrator.

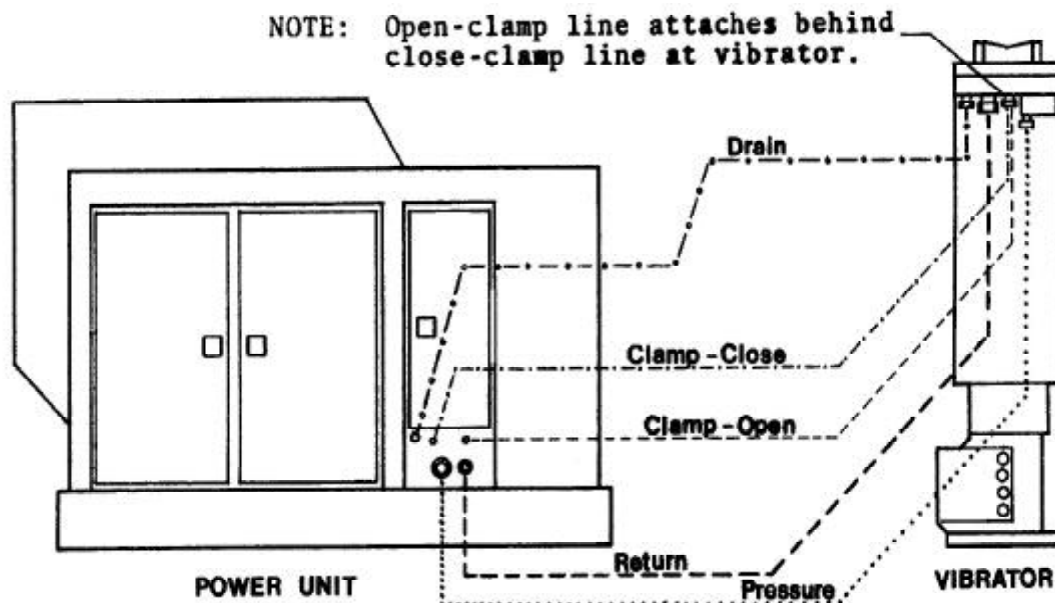

FIG. 1



MODEL 416  
VIBRATORY  
DRIVER/EXTRACTOR

# OPERATING INSTRUCTIONS

## II. PREPARATION FOR OPERATION

### E. CONNECTION OF HYDRAULIC HOSES (CONTINUED)

#### 2. Connection of hoses at vibrator.

- a. The vibrator is usually shipped with the hoses attached to the vibrator. If the hoses have been shipped separately, they must be connected in the field. Fig. 1 on the previous page shows the correct arrangement of the five hose lines connecting the power unit to the vibrator.

**CAUTION:** Starting the vibrator with the hoses reversed will most likely result in ruptured hoses.

- b. The vibrator is usually shipped with the hydraulic clamp and hoses attached. If the clamp has been shipped separately, the two hose lines connecting the clamp to the vibrator must be connected. Fig. 2 shows the correct arrangement of these hoses. For caisson clamps, four hoses must be connected. The two connections on the opposite end of the vibrator are reversed from the positions in Fig. 2. Clamp hose connections are normally stamped "O" for open and "C" for close so that lines may be routed to the proper terminals.

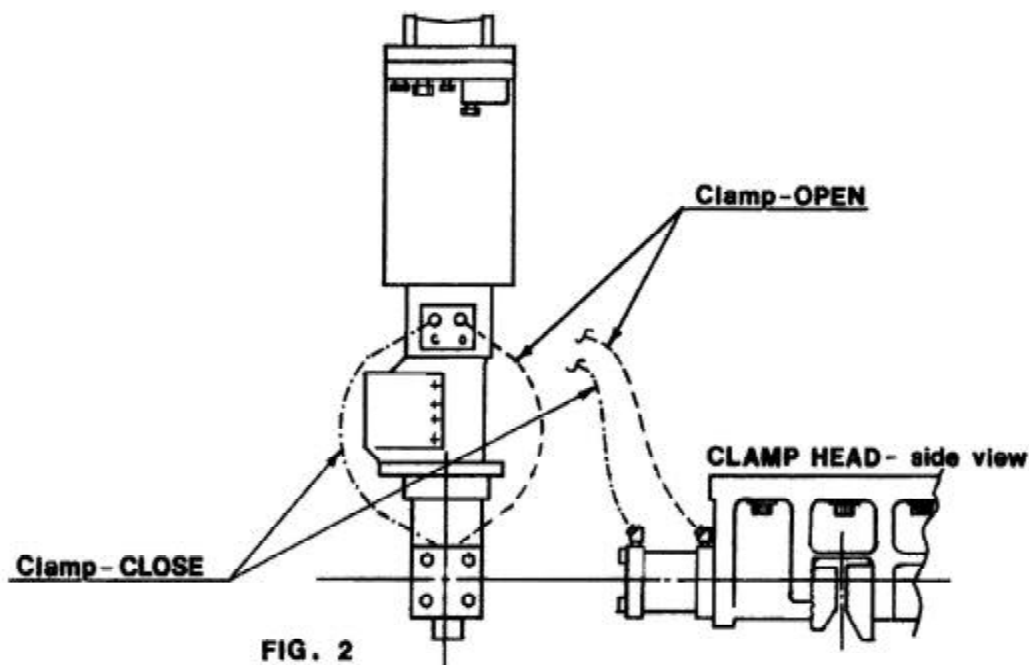



MODEL 416  
VIBRATORY  
DRIVER/EXTRACTOR

# OPERATING INSTRUCTIONS

## II. PREPARATION FOR OPERATION

### F. BLEEDING HYDRAULIC CLAMP HOSES

1. When the vibrator and hydraulic clamp are shipped with all hoses attached (between vibrator and clamp and five main hoses connected to the vibrator), the hoses are usually full of fluid and may be used immediately. However, if any of the clamp hoses are connected at the jobsite or if air is present in hoses, they must be bled prior to operation.
2. Read SECTION III - OPERATING INSTRUCTIONS.
3. Start and warm up the diesel engine in accordance with SECTION III-C - STARTING AND WARMING UP ENGINE.
4. With the engine warmed-up and running at 1500 RPM, loosen the close-clamp line at the hydraulic clamp. Turn the clamp switch on the remote-control pendant to CLOSE. Wait until fluid flows from the connection at the hydraulic clamp. When fluid flows without air, tighten the connection.
5. After the line has been bled, alternately turn the clamp switch to CLOSE and OPEN to insure that the clamp is working properly. It may be necessary to bleed the line more than once. The open-clamp line may also require bleeding.

### G. FILLING VIBRATOR PRESSURE HOSE

1. The vibrator is usually shipped with the vibrator hydraulic hoses full of fluid and the unit may be used immediately. However, if the pressure hose has been removed from the vibrator, the hose should be allowed to fill with hydraulic fluid prior to full speed operation. It is not necessary to have the return hose filled with fluid.
2. Read SECTION III - OPERATING INSTRUCTIONS.
3. Start and warm up the diesel engine in accordance with SECTION III-C - STARTING AND WARMING UP ENGINE.
4. With the engine warmed up and running at 1500 RPM, the pressure hose will fill with hydraulic fluid in about ten minutes. Wait ten minutes for this to occur. Do not turn the vibrator switch (FORW/REV) on the control pendant. It should be in the neutral position.



MODEL 416  
VIBRATORY  
DRIVER/EXTRACTOR

# OPERATING INSTRUCTIONS

## III. OPERATING INSTRUCTIONS

### A. COMPLETION OF SET-UP AND MAINTENANCE

1. Complete all preparations as described in Section II.
2. Read Section IV - MAINTENANCE AND ADJUSTMENTS and perform any required maintenance.

### B. CONTROL PANEL

1. The control panel (Fig. 3) at the side of the power unit contains the Operating Panel with controls and gages for the diesel engine and the OPERATION AND MAINTENANCE INSTRUCTIONS.
2. The operating panel contains the following controls and gages:

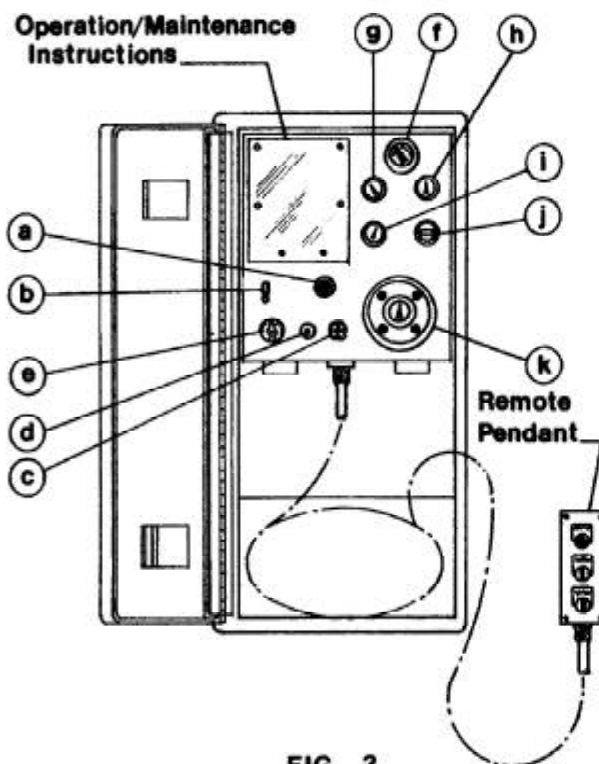

FIG. 3

- a. Hydraulic Fluid Warning Light - comes on if hydraulic fluid temp. is below 60°F (16°C).
- b. Main Power Switch - on/off switch for 12V electrical power.
- c. Engine Throttle - controls engine speed.
- d. Shut-Down Reset Button - must be held in on start-up until oil pressure exceeds 30 PSI.
- e. Engine Start Switch
- f. Tachometer - indicates engine speed.
- g. Engine Oil Pressure Gage
- h. Engine Water Temperature Gage
- i. Engine Ammeter
- j. Engine Hourmeter
- k. Four-Way Pressure Gage (MULTI-GAGE)
  1. OPEN - pressure to OPEN CLAMP line.
  2. CLOSE - pressure to CLOSE CLAMP line.
  3. DRIVE - pressure in line to vibrator motors.
  4. BRAKE - pressure in line from vibrator motors.

3. The OPERATION AND MAINTENANCE INSTRUCTIONS on the control panel are there as reminders only. They are concise and therefore not intended to substitute for a thorough understanding of this Operating Manual.



MODEL 416  
VIBRATORY  
DRIVER/EXTRACTOR

# OPERATING INSTRUCTIONS

## III. OPERATING INSTRUCTIONS

### C. STARTING AND WARMING UP ENGINE

1. Before starting the engine, read the CATERPILLAR OPERATION GUIDE carefully. Follow the engine starting, operating and maintenance procedures in that manual.
2. The diesel engine should not be started if the temperature of the hydraulic fluid is below 0°F. The temperature may be read on the gage on the hydraulic reservoir. If ambient temperatures below 0°F are anticipated, an immersion heater for the hydraulic fluid is available. Consult ICE for details.
3. The MAIN SWITCH on the control panel should be ON. The vibrator switch (FORW/REV) on the control pendant should be in the neutral position.
4. Pull out the ENGINE THROTTLE about half way. Press the button on the end of the throttle for adjustment.
5. Hold SHUTDOWN RESET button and turn the ENGINE START switch to START position. Start the engine using starting aids as necessary. If the engine fails to start after 30 seconds of cranking, allow the starter to cool for two minutes before repeating the starting procedure.
6. As the engine starts, release the ENGINE START switch. It will return to the RUN position.
7. Adjust the throttle until the engine is running at 1500 RPM and allow to warm-up for five minutes.
8. Allow the temperature of the hydraulic fluid to come up to at least 30°F before starting vibrator.

### D. WARMING HYDRAULIC FLUID

1. The vibrator should not be operated at full speed if the temperature of the hydraulic fluid is below 60°F. The HYDRAULIC FLUID COLD light on the control panel will be on if fluid temperature is below 60°F. Also check gage on reservoir.



MODEL 416  
VIBRATORY  
DRIVER/EXTRACTOR

# OPERATING INSTRUCTIONS

## III. OPERATING INSTRUCTIONS

### D. WARMING HYDRAULIC FLUID (CONTINUED)

2. If temperature of the hydraulic fluid is below 60°F, set the diesel engine at 1500 RPM and run the vibrator until the temperature of the hydraulic fluid exceeds 60°F. The Hydraulic Fluid Warning light will then go off.
3. When the engine is warmed up and hydraulic fluid temperature is at least 60°F, full speed operation may begin. Adjust the throttle so the engine is running at 2800 RPM. The engine should maintain about 2600 RPM under load.

CAUTION: Do not operate the vibrator if hydraulic fluid temperature exceeds 160°F as this may damage hydraulic components.

### E. OPERATION OF REMOTE-CONTROL PENDANT

1. The operation of the vibratory driver is controlled by the remote-control pendant. The pendant is connected to the control cabinet with 50 feet of electrical cable to permit operation from any advantageous position near the vibrator.
2. The pendant has two two-way switches and an indicator light.

a. To Clamp to Pile:

Position vibratory driver on pile. Turn the clamp switch on the pendant to CLOSE. The CLAMP light on the pendant will come on when the hydraulic clamp has achieved adequate pressure to permit vibration to begin. The light should normally come on in a few seconds.

b. To Start Vibration:

Turn the vibrator switch to FORWARD.

NOTE: The vibrator switch reads FORWARD/REVERSE instead of START/STOP because the Model 250 power unit also operates ICE earth augers.

CAUTION: Do not turn the switch to FORWARD until the CLAMP light in the pendant comes on indicating adequate clamping pressure.





MODEL 416  
VIBRATORY  
DRIVER/EXTRACTOR

# OPERATING INSTRUCTIONS

## III. OPERATING INSTRUCTIONS

### E. OPERATION OF REMOTE-CONTROL PENDANT (CONTINUED)

#### c. To Stop Vibration:

Turn the vibrator switch to REVERSE. When the vibration stops, turn the switch to OFF.

#### d. To Unclamp from Pile:

Turn the CLAMP switch to OPEN to release the hydraulic clamp so that the vibrator can be removed from the pile.

CAUTION: Do not turn the switch to OPEN until a visual check indicates that vibration has stopped.

### F. CHANGING FREQUENCY

1. In order to provide maximum flexibility in achieving optimum pile penetration and extraction rates, the frequency of the vibratory driver is adjustable.
2. The frequency can be varied from 400 to 1500 vibrations per minute by changing engine speed. Engine speed is changed with the ENGINE THROTTLE on the control panel. Vibrator frequency corresponds to engine speed according to the table shown below:

<u>ENGINE RPM</u>	<u>VIBRATOR VPM</u>
2600	1500
2400	1384
2000	1153
1800	1037
1400	805
1000	574
700	400



**MODEL 416  
VIBRATORY  
DRIVER/EXTRACTOR**

# **OPERATING INSTRUCTIONS**

## **III. OPERATING INSTRUCTIONS**

### **G. SHUTDOWN**

1. Stop the vibrator.
2. Allow the diesel engine to run for five minutes at 1500 RPM.
3. Reduce speed to low idle for about thirty seconds.
4. Stop the engine by turning the ENGINE START switch to OFF.

**CAUTION:** If the diesel engine is shut down while the vibrator is clamped to a pile, the clamp check valve will keep the vibrator clamped to the pile. However, system leakage could result in a loss of clamp pressure. Therefore, it is not recommended to leave the vibrator clamped to a pile when the diesel engine is not running.

### **H. EXTRACTING LINE PULL LOAD INDICATOR**

1. Extracting line pull load may be read on all units which have the load indicator (Fig. 4). As the line pull increases, more of the indicator will be visible from under the suppressor housing. When the black zone is entirely visible, the line pull is approximately 10 tons. When both the black and the yellow zones are visible, the line pull is approximately 20 tons, etc.

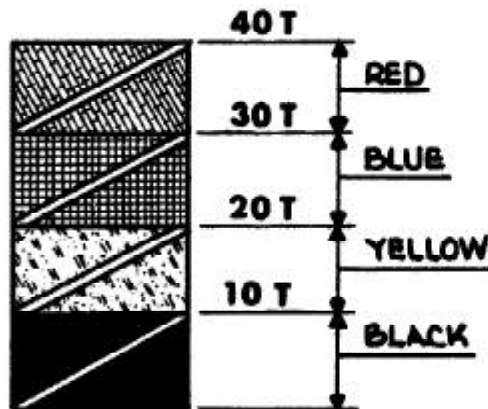

**FIG. 4**



MODEL 416  
VIBRATORY  
DRIVER/EXTRACTOR

# OPERATING INSTRUCTIONS

## IV. MAINTENANCE AND ADJUSTMENTS

### A. GENERAL

Preventive maintenance includes normal servicing that will keep the engine, vibratory driver and power unit in peak operating condition and prevent unnecessary trouble from developing. This servicing consists of periodic lubrication and inspection of the moving parts and accessories of the unit.

Lubrication is an essential part of protective maintenance, controlling to a great extent the useful life of the unit. Different lubricants are needed and some components in the unit require more frequent lubrication than others. Therefore, it is important that the instructions regarding types of lubricants and frequency of their applications be closely followed.

To prevent minor irregularities from developing into serious conditions that might involve shut-down and major repair, several other services or inspections are recommended for the same intervals as the periodic lubrications. The purpose of these services or inspections is to assure the uninterrupted operation of the unit.

Thoroughly clean all lubrication fittings, caps, filler and level plugs and their surrounding surfaces before servicing. Prevent dirt from entering with lubricants and coolants. The intervals given in the schedule are based on normal operation. Perform these services, inspections, etc., more often as needed for operation under abnormal or severe conditions.

### B. DAILY

1. Check the entire unit prior to and during start-up each day or at the beginning of each shift.



MODEL 416  
VIBRATORY  
DRIVER/EXTRACTOR

# OPERATING INSTRUCTIONS

## IV. MAINTENANCE AND ADJUSTMENTS

### B. DAILY (CONTINUED)

2. Prior to starting the diesel engine at each shift, check the following items:

- a. Visibly inspect all bolts, nuts and screws including the bolts fastening the hydraulic clamp to the vibration case to insure they are tight.
- b. Tighten bolts holding gripping jaws in hydraulic clamp.
- c. Grease plunger in hydraulic clamp with any good multi-purpose grease.
- d. Check the oil level in the vibration case and add oil if required. The oil level should be in the middle of the sight glass. Change oil if milky or black.
- e. Check the fluid level in the hydraulic reservoir and refill if necessary.

**CAUTION:** It is absolutely imperative that no dirt or other impurities be permitted to contaminate the hydraulic fluid. Any contamination will drastically shorten the life of the high-pressure hydraulic system.

- f. Visually check all hoses for signs of damage or cuts that might cause hose failure during operation. Be sure all connections are tight, especially the quick-disconnect couplers.
  - g. Visually inspect all suppressor elastomers.
  - h. Electrical components need no maintenance except periodic wiping with a clean, dry, lint-free cloth to remove dust.
  - i. Perform all daily maintenance checks and lubrication indicated in the CATERPILLAR OPERATION GUIDE.
3. After start-up, check the following:
- a. Check all hydraulic hoses for leaks. Make sure they hang freely with no kinks.
  - b. Check pump and all hydraulic manifolds for leaks.
  - c. Check the filter indicators. The filter on the vibrator may be checked at any time. The return filter on the power pack must be checked with the diesel engine running.



MODEL 416  
VIBRATORY  
DRIVER/EXTRACTOR

# OPERATING INSTRUCTIONS

## V. MAINTENANCE AND ADJUSTMENTS

### C. 100 HOURS, 150 HOURS AND OTHER

1. At 100 hours, drain and add new lubricant in the vibration case.
2. Perform all maintenance checks and lubrication indicated in the CATERPILLAR OPERATION GUIDE.

### D. ANNUALLY

Have the hydraulic fluid tested by a local hydraulic service center. Replace if required.

NOTE: The frequency with which hydraulic fluid requires changing depends both on the condition of the fluid and the operating conditions involved. The most accurate method for determining when or how often fluid should be changed is to have a laboratory fluid analysis done periodically.

### E. SEVERE CONDITIONS

1. The servicing intervals specified are based on normal operating conditions. Operation under unusual conditions require some adjustments in servicing intervals.
2. When the average temperature is above 80°F or below -10°F, reduce service time intervals by one-half of those specified above.
3. When operating in the presence of dust or sand, reduce service time intervals by one-half of those specified.
4. When operating in excess of twelve hours per day, reduce service time intervals by one-half of those specified.
5. When operating in air with high salt or moisture, the servicing intervals need not usually be changed. However, the unit should be inspected weekly to determine if additional servicing might be required.
6. For extended inactive periods, the engine should be started at least once a week and run until thoroughly warm. Servicing time intervals may be extended from those specified, but for actual time intervals, contact your local Caterpillar dealer, especially during lengthy storage periods.



MODEL 416  
VIBRATORY  
DRIVER/EXTRACTOR

# OPERATING INSTRUCTIONS

## IV. MAINTENANCE AND ADJUSTMENTS

### F. LUBRICATION

#### 1. Crankcase (Diesel Engine)

- a. Follow the engine manufacturer's maintenance schedule and the lubricating oil specifications outlined in the CATERPILLAR OPERATION GUIDE.
- b. The lubricant shall meet the performance requirements of API Service Classifications CD or MIL-L-2104C.
- c. New engines are shipped with MOBIL DELVAC SUPER 15W-40, but the following multi-grade crankcase oils are recommended for use or replacement in normal operation (10°F to 90°F) (-12°C to 32°C).

AMOCO	- 15W-40	300
ARCO	- 15W-40	Fleet S3 Plus
BORON (BP)	- 15W-40	Vanellus C Extra
CHEVRON	- 15W-40	Delo 400
CITGO	- 15W-40	C500 Plus
CONOCO	- 15W-40	Fleet Supreme
EXXON	- 15W-40	XD3
GULF	- 15W-40	Super Duty Plus
MOBIL	- 15W-40	Delvac Super
PHILLIPS	- 15W-40	Super HD II
SHELL	- 15W-40	Rotella T
SUN	- 15W-40	Sunfleet Super C
TEXACO	- 15W-40	Ursa Super Plus
UNION	- 15W-40	Guardol
VALVOLINE	- 15W-40	All Fleet

- d. For operation in extreme sub-zero climate, refer to the CATERPILLAR OPERATION GUIDE - Crankcase Lubricating Oils or contact the nearest Caterpillar representative.

#### 2. Hydraulic System

To maintain the maximum operating efficiency in the precision parts of the hydraulic system, it is extremely important to eliminate factors which can cause breakdowns or unsatisfactory performance in the system. Among the most common of these factors are rust, corrosion, contamination and products of oil deterioration. Most problems can be minimized or avoided simply by maintaining a disciplined preventive maintenance program.



MODEL 416  
VIBRATORY  
DRIVER/EXTRACTOR

# OPERATING INSTRUCTIONS

## IV. MAINTENANCE AND ADJUSTMENTS

### F. LUBRICATION (CONTINUED)

Some simple steps to follow as part of that program are:

- a. Keep stored oil dry and clean at all times and always store in clean containers.
- b. Always clean tools, spouts, lids, funnels, etc. when used in conjunction with the transfer of oil.
- c. Never put dirty oil into the hydraulic system. Use only clean, uncontaminated oil of the types recommended below. Never return to the system any fluid which has leaked out.

NOTE: Foreign material in the hydraulic system can drastically effect the life and operation of many hydraulic component parts.

- d. Clean or replace filter elements at the first indication that they are dirty or ineffective.

Mixing of different manufacturers' hydraulic fluid is not recommended. However, it can be done if the fluids are miscible (contain the same base and additive). It may be necessary to contact an oil supplier to determine this.

New power units are shipped with MOBIL DTE-15 hydraulic oil. The following recommended fluids may be used when replacing fluid in the hydraulic system.

#### FIRST Preference Group:

MOBIL	DTE-15
SUN	2105

#### SECOND Preference Group:

AMOCO	Rykon MV
ARCO	Duro AW32
CHEVRON	Hydraulic AW32
PHILLIPS	Magnus A32
SHELL	Tellus 32

#### THIRD Preference Group:

BORON	Energol HLP32
CITGO	All-Temp HD
CONOCO	Super 32
EXXON	Nuto H32
GULF	Harmony 32AW
SUN	Sunvis 805 MG
TEXACO	Rando HD AZ32
UNION	Unax AW32



MODEL 416  
VIBRATORY  
DRIVER/EXTRACTOR

# OPERATING INSTRUCTIONS

## IV. MAINTENANCE AND ADJUSTMENTS

### F. LUBRICATION (CONTINUED)

Whenever fluids from the second preference group are used, it is necessary to test the oil more often to insure that viscosity remains within recommended limits while in service. Using fluids from the third preference group requires even a more discerning inspection than use of fluids from the second group.

The recommended fluids were chosen based on the hydraulic system operating temperature range being 5°F (-15°C) (cold [ambient] start-up) to 160°F (71°C) (maximum operating).

When operating in arctic conditions, it is recommended to use an immersion heater to pre-heat the oil prior to starting. It may also be necessary in extremely cold or hot climates to use a different viscosity oil which is better adapted to adverse conditions. Contact the nearest oil supply representative for suggested procedures.

MOBIL DTE-15 hydraulic fluid is available from ICE in five gallon cans. See SECTION VIII - ORDERING PARTS, page VIII-44.

#### 3. Vibration Case

The fluid level is easily read through the sight glass located at the lower center of the vibration case wall, opposite the motor side. Lubricating oil may be added when necessary, through either of the holes in the vibration case top plate after removing the 1" pipe plugs. The oil may be drained by removing either of the 3/4" pipe plugs in the vibration case base plate at the ends of the case and tilting the unit.

The most preferred lubricating oil is a synthetic lubricant, since synthetics were designed for applications where service conditions are more severe due to high operating temperatures and they have good oxidation stability. Synthetics also provide much longer service life than natural petroleum based lubricants consequently resulting in fewer maintenance hours spent on the mechanical service of the unit. Therefore, whenever the first preferred oil is not available, or desired, and the choice is to change to an oil from the second or third preferred group (natural petroleum base) the need to test the oil oftener becomes more essential.





MODEL 416  
VIBRATORY  
DRIVER/EXTRACTOR

# OPERATING INSTRUCTIONS

## IV. MAINTENANCE AND ADJUSTMENTS

### F. LUBRICATION (CONTINUED)

- a. The vibration case lubricant installed at the factory is MOBIL SHC-634 (a synthetic) but any of the following recommended gear lubes may be used when changing lubricants:

FIRST Preference Group (Synthetic):  
MOBIL SHC-634

SECOND Preference Group (Natural Petroleum Base):

BORON	Gearep 140
CHEVRON	Gear Comp. NL460
CITGO	Premium MP 85W-140
CITGO	Standard MP 85W-140
GULF	Lub 85W-140
PHILLIPS	SMP 85W-140
SHELL	Omala 460
SUN	Sunep 1110

THIRD Preference Group (Natural Petroleum Base):

AMOCO	Perma Gear EP140
ARCO	Pennant NL 460
CONOCO	EP 460
EXXON	Spartan EP 460
PHILLIPS	AP 140
TEXACO	Meropa 460
UNION	MP 85W-140
VALVOLINE	Gear Lub 85W-140

MOBIL SHC-634 lubricant is available from ICE in five gallon cans. See SECTION VIII - ORDERING PARTS, page VIII-44.

### G. CAPACITIES

1. Diesel Engine Crankcase	14	Quarts
2. Hydraulic System (Reservoir)	270	Gallons
3. Vibration Case	2.5	Gallons
4. Fuel Tank Sub-Base (Diesel)	110	Gallons
5. Engine Cooling System	40	Quarts

### H. DRAINING AND FILLING HYDRAULIC FLUID RESERVOIR

1. The hydraulic reservoir is drained by removing a plug on the bottom of the reservoir.
2. The hydraulic reservoir is filled by the manual pump mounted on the back (engine side) of the reservoir. All fluid is pumped to the reservoir through the return filter (F2) to insure no dirt enters the hydraulic system.



MODEL 416  
VIBRATORY  
DRIVER/EXTRACTOR

# OPERATING INSTRUCTIONS

## IV. MAINTENANCE AND ADJUSTMENTS

### I. CLEANING HYDRAULIC PICK-UP FILTER

1. Drain hydraulic reservoir (See Section H, previous page).
2. Remove the top cover of the reservoir.

CAUTION: It is absolutely imperative that no dirt or other impurities be permitted to contaminate the hydraulic fluid. Any contamination will drastically shorten the life of the high-pressure hydraulic system.

3. The pick-up filter is connected to the input pipe for the hydraulic drive pump. Remove the entire filter assembly by unscrewing from inner wall of reservoir.
4. Disassemble and clean entire filter in clean solvent or diesel fuel.
5. Replace filter. Carefully replace top cover of reservoir after cleaning so that no dirt is allowed to fall into reservoir opening. Refill reservoir with recommended hydraulic fluid.

### J. CHANGING HYDRAULIC RETURN FILTER ELEMENT

1. The return filter is located in the hydraulic reservoir below the hand pump.
2. To remove elements, remove the four hex-head screws and remove the cover assembly. Screw driver slots are provided at the bottom to aid in removing the filter cover.
3. Remove the bypass valve and spring assembly from filter housing. Remove the two filter elements.
4. Clean filter housing interior and all component parts with a lint-free rag.
5. Check O-ring for damage. Lubricate with multi-purpose grease.
6. Install two new elements.
7. Replace bypass valve and spring assembly into housing.
8. Replace filter cover and tighten four hex screws.



MODEL 416  
VIBRATORY  
DRIVER/EXTRACTOR

# OPERATING INSTRUCTIONS

## IV. MAINTENANCE AND ADJUSTMENTS

### K. CHANGING HYDRAULIC VIBRATOR FILTER ELEMENT

1. The vibrator filter is located behind the hose guard at the end of the vibration suppressor.
2. Remove the two screws at the bottom of the hose guard and rotate the guard upward to expose the filter.
3. Unscrew the filter can. It should be firmly hand tight.
4. Remove the old filter element and insert the new element.
5. Remove the O-ring and check it for cuts and nicks. Replace if damaged. Lubricate with multi-purpose grease.
6. Screw in the filter can with the new element until it is firmly hand tight.
7. Replace the hose guard.

### L. BOLT TORQUE INFORMATION

Torque, in foot-pounds, is determined by the length of the wrench handle (in feet) multiplied by the weight (or force in pounds) applied at the end of the handle. For example, if the wrench is one foot long and five pounds of force is applied at the end of the handle, the total torque applied would be five foot pounds. A six inch wrench would require ten pounds of force to obtain five foot pounds of torque.

Proper use of the torque wrench is important. To obtain the listed torques, a steady pull should be exerted to the handle until the desired torque is reached.



MODEL 416  
VIBRATORY  
DRIVER/EXTRACTOR

# OPERATING INSTRUCTIONS

## IV. MAINTENANCE AND ADJUSTMENTS

### L. BOLT TORQUE INFORMATION (CONTINUED)

The following torque specifications apply to the bolts from the component assemblies listed. Whenever any of these bolts are replaced, the given torque specifications should be adhered to.

<u>VIBRATION SUPPRESSOR</u>		<u>Page VIII-6</u>
Item 10, 28, 63	3/8"-16	41 Ft/Lbs
Item 6, 14, 26, 50, 60	1/2"-13	119 Ft/Lbs
Item 12	1/2"-13	71 Ft/Lbs
Item 3, 40, 43, 48, 67	5/8"-11	233 Ft/Lbs
Item 36	3/4"-10	417 Ft/Lbs

<u>VIBRATION CASE</u>		<u>Page VIII-10</u>
Item 4, 16	1/2"-13	119 Ft/Lbs
Item 8	5/8"-11	233 Ft/Lbs



MODEL 416  
VIBRATORY  
DRIVER/EXTRACTOR

# OPERATING INSTRUCTIONS

## V. HYDRAULIC CIRCUITRY (REFERENCE:HYDRAULIC SCHEMATIC PG V-4)

### A. HYDRAULIC CLAMP

With the diesel engine running, hydraulic fluid is taken from the reservoir by the clamp pump (P2). The clamp pump flow returns to the reservoir if the clamp switch on the pendant has not been moved.

Turning the clamp switch on the control pendant to CLOSE activates the CLAMP CONTROL VALVE (V1). Hydraulic fluid is directed to the CLOSE CLAMP side of the hydraulic CYLINDER (CYL) in the hydraulic clamp. The clamp closes. Clamping pressure is indicated by the clamp pressure gage (GA-1) in the CLOSE position. When clamping pressure reaches approximately 4000 PSI, the CLAMP PRESSURE SWITCH (PS-1) deactivates the CLAMP CONTROL VALVE (V1), which directs the flow from the clamp pump to the reservoir. Pressure at the clamp is maintained by the CLAMP CHECK VALVE (CV5). If clamping pressure falls below 4000 PSI, the CLAMP PRESSURE SWITCH activates the CLAMP CONTROL VALVE to restore pressure.

Turning the clamp switch on the control pendant to OPEN activates the CLAMP CONTROL VALVE (V1). Hydraulic fluid is directed to the OPEN CLAMP side of the hydraulic cylinder. The pressure in the OPEN CLAMP line opens the CLAMP CHECK VALVE (CV5). The clamp opens. Pressure in the OPEN CLAMP line is indicated by the clamp pressure gage (GA-1) in the OPEN position.

Pressure in the clamping circuit is limited to 4300 PSI by the clamp relief valve (RV2). The quick-disconnect couplers (QD3 & QD4) permit decoupling of the clamp hoses at the power unit.

### B. VIBRATOR DRIVE

With the diesel engine running, hydraulic fluid is taken from the reservoir by the DRIVE PUMP (P1). Prior to entering the drive pump, the fluid is filtered by the PICK-UP FILTER (F1). The pressure opens all the cartridges (A1, A2, B1-B4) and vents the hydraulic fluid back to the reservoir through the RETURN FILTER (F2). if the vibrator switch on the pendant has not been moved.



MODEL 416  
VIBRATORY  
DRIVER/EXTRACTOR

# OPERATING INSTRUCTIONS

## V. HYDRAULIC CIRCUITRY

### B. VIBRATOR DRIVE (CONTINUED)

Turning the vibrator switch, on the control pendant, to FORWARD activates the FORWARD SOLENOID on the CONTROL VALVE (V2). By blocking the pilot flow from cartridges (A1 and B3), the CONTROL VALVE (V2) causes these cartridges to close, thus directing pump flow to the VIBRATOR MOTORS (M).

Full motor speed is reached within a few seconds and the motor drive pressure is indicated by the PRESSURE MULTI-GAGE (GA-1) in the DRIVE position. Maximum drive pressure is limited to approximately 4500 PSI by the START RELIEF VALVE (RV1). The START RELIEF VALVE (RV1), when opened by pressure, permits a small pilot flow from cartridges (A1 and B3). This pilot flow causes cartridges (A1 and B3) to partially open and allows some or all of the pump flow to return to the reservoir. Flow to the motors is filtered by the vibrator FILTER (F3). Case drain fluid from the motors returns to the reservoir. Case drain pressure is limited to 50 PSI by the case drain RELIEF VALVE (RV3).

Turning the vibrator switch, on the control pendant, to REVERSE activates the REVERSE SOLENOID on the CONTROL VALVE (V2) which releases cartridges (A1 and B3) and then closes cartridges A2 and B2 by blocking their pilot flow. Cartridges A2 and B2 direct pump flow toward the reverse side of the hydraulic motors (M) causing the motors to stop within a few seconds. Reverse pressure is limited to 500 PSI by the BRAKE RELIEF VALVE (RV4) by limiting the pressure of pilot flow from cartridges A2 and B2. Brake pressure is indicated by the PRESSURE MULTI-GAGE (GA-1) in the BRAKE position.

Hydraulic fluid returns to the reservoir by one of two paths. When the fluid temperature is below 100°F, the COOLER SOLENOID VALVE (V3) closes cartridge (B1) by blocking its pilot flow. Return fluid is then forced through cartridge B4, which opens at 65 PSI, and goes directly to the reservoir through filter F2. The opening pressure of cartridge B4 is controlled by CHECK VALVE (CV2). When fluid temperature exceeds 100°F, the COOLER SOLENOID VALVE (V3) opens cartridge B1, permitting fluid to return to the reservoir through the HEAT EXCHANGER (HE) and FILTER (F2) without pressure loss. If the HEAT EXCHANGER (HE) would become clogged, excessive pressure would be prevented by cartridge B4, bypassing excess flow and limiting pressure to 65 PSI.



MODEL 416  
VIBRATORY  
DRIVER/EXTRACTOR

# OPERATING INSTRUCTIONS

## V. HYDRAULIC CIRCUITRY

### B. VIBRATOR DRIVE (CONTINUED)

The quick-disconnect couplers (QD1, QD2 and QD5) permit decoupling of the drive and case drain hoses at the power unit.

### C. OTHER

Returning fluid is filtered by the RETURN FILTER (F2). The return FILTER CHECK VALVE (CV1) prevents fluid loss from the reservoir when the filter elements are removed.

A manual PUMP (MP) is provided to fill the hydraulic reservoir. A CHECK VALVE (CV4) prevents loss of fluid from the reservoir back through the pump.

A TEMPERATURE SWITCH (TS) located in the reservoir operates the hydraulic fluid cold light and the oil cooler valve (V3).

The HEAT EXCHANGER (HE) cools the hydraulic fluid returning from the vibrator.

Motor cavitation is prevented in the braking operation by the CHECK VALVE (CV6).



MODEL 416  
VIBRATORY  
DRIVER/EXTRACTOR

# OPERATING INSTRUCTIONS

## V. HYDRAULIC CIRCUITRY

HYDRAULIC SCHEMATIC - 250

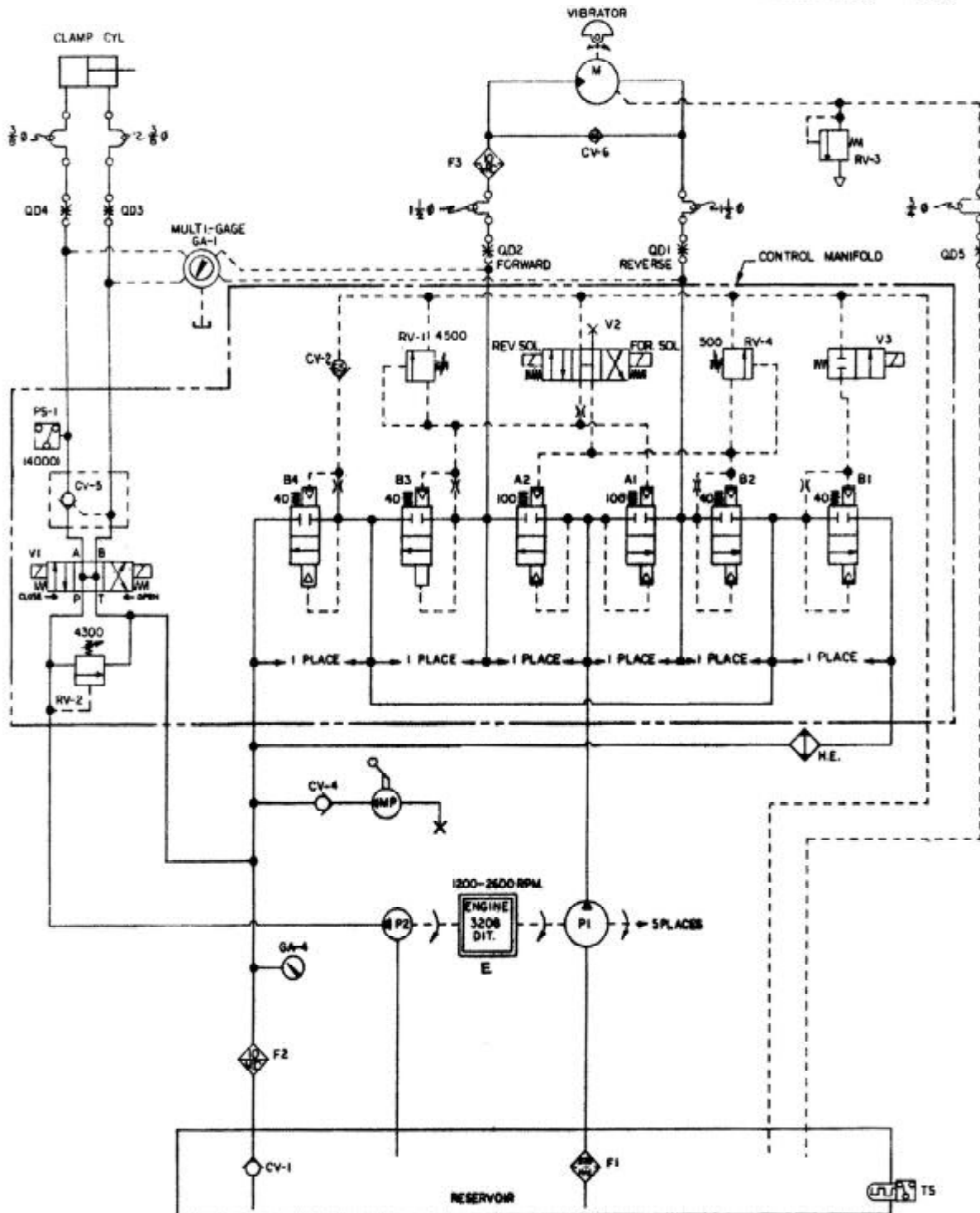





MODEL 416  
VIBRATORY  
DRIVER/EXTRACTOR

# OPERATING INSTRUCTIONS

## V. HYDRAULIC CIRCUITRY

### D. HYDRAULIC COMPONENTS LIST

<u>Notation</u>	<u>Description</u>	<u>Part Number</u>	<u>Page Ref.</u>
CV2	Check Valve	140135	VIII-31
CV4	Manual Pump Check Valve	100451	VIII-23
CV5	Clamp Check Valve	110149	VIII-31
CV6	Check Valve - Vibrator	110731	VIII- 9
E	Diesel Engine	100944	VIII-19
F1	Pick-Up Filter	400087	VIII-19
F2	Return Filter	100583	VIII-19
	CV1 Return Filter Check Valve		
F3	Vibrator Filter	100971	VIII- 7
GA-1	Pressure Gage	100925	VIII-27
GA-4	Indicator Gage	100775	VIII-24
HE	Heat Exchanger	400099	VIII-19
M	Motor	100779	VIII-11
MP	Manual Pump	100447	VIII-23
P1	Drive Pump	100894	VIII-19
P2	Clamp Pump	100892	VIII-19
PS-1	Clamp Pressure Switch	810033	VIII-31
QD1	Vibrator Return Disconnect	100891	VIII-21
QD2	Vibrator Pressure Disconnect	110692	VIII-21
QD3	Clamp Open Disconnect	100777	VIII-21
QD4	Clamp Close Disconnect	100245	VIII-21
QD5	Case Drain Disconnect	400095	VIII-21
RV1	Relief Valve	140131	VIII-31
RV2	Clamp Relief Valve	100898	VIII-31
RV3	Case Drain Relief Valve	100032	VIII- 7
RV4	Brake Valve	140133	VIII-31
TS	Temperature Switch	400115	VIII-24
V1	Control Valve	130033	VIII-31
V2	Start Valve	130033	VIII-31
V3	Cooler Valve	100872	VIII-31
CYL	Hydraulic Clamp Cylinder		



**MODEL 416  
VIBRATORY  
DRIVER/EXTRACTOR**

# **OPERATING INSTRUCTIONS**

**VI. ELECTRICAL CIRCUITRY (REFERENCE: ELECTRICAL SCHEMATIC PG VI-3)**

**A. DIESEL ENGINE**

The BATTERY provides 12-volt current to start the diesel engine. In order to start the diesel engine, the circuit breaker (MAIN POWER) switch should be ON and the vibrator switch on the remote control pendant should be in the neutral position. This insures that the vibrator will not start when the engine begins. Turning the ENGINE START SWITCH to START energizes the START RELAY which energizes the START MOTOR and turns over the diesel engine. If fuel is available, the diesel engine will start. In order for fuel to be available to the engine, the SAFETY SWITCH must be closed to energize the FUEL SOLENOID. The FUEL SOLENOID opens the fuel valve and allows fuel to flow to the engine. With the diesel engine running, the AMMETER indicates charging amperes. The HOUR METER indicates engine operating hours.

A system of safety controls shuts off the fuel supply, which stops the diesel engine in the event that engine water temperature is too high or engine oil pressure is too low. The heart of the safety system is the SAFETY SWITCH which is normally closed, thereby providing current to operate the HOUR METER and to energize the FUEL SOLENOID. Energizing the fuel solenoid opens the fuel valve and allows fuel to flow to the diesel engine. The SAFETY SWITCH must remain closed so that fuel continues to flow to the diesel engine.

If the timing delay coil in the SAFETY SWITCH is energized, the SAFETY SWITCH will open shutting off the fuel to the diesel engine. The engine will stop. The time delay coil may be energized by either of the following devices:

1. ENGINE OIL PRESSURE GAGE - If oil pressure is below 15 PSI, the contacts of the gage will be closed providing current to energize the time delay coil. On start-up, the reset button of the SAFETY SWITCH (on the control panel) must be held until oil pressure exceeds 30 PSI.
2. ENGINE WATER TEMPERATURE GAGE - If water temperature exceeds 210°F, the contacts of the gage will close energizing the time delay coil.

The diesel engine is stopped by turning the ENGINE START SWITCH to OFF. This will de-energize the FUEL SOLENOID shutting off fuel to the engine.



**MODEL 416  
VIBRATORY  
DRIVER/EXTRACTOR**

# **OPERATING INSTRUCTIONS**

## **VI. ELECTRICAL CIRCUITRY**

### **B. HYDRAULIC CLAMP**

With the diesel engine running, turning the clamp switch (OPEN-CLOSE) on the control pendant to CLOSE energizes the close-clamp solenoid (CLOSE SOL.). This operates the clamp hydraulic valve and closes the clamp.

When the pressure in the close-clamp hydraulic circuit reaches 4000 PSI, the pressure switch (PS-1) opens and de-energizes the close-clamp solenoid and turns on the CLAMP LIGHT on the control pendant. If close-clamp pressure falls below 4000 PSI, the pressure switch closes and re-energizes the close-clamp solenoid to rebuild pressure. The CLAMP LIGHT on the pendant goes out. When pressure returns to 4000 PSI, the pressure switch opens de-energizing the close-clamp solenoid and turns on the CLAMP LIGHT.

With the diesel engine running, turning the clamp switch (OPEN-CLOSE) to OPEN energizes the open-clamp solenoid (OPEN SOL.). The clamp opens.

### **C. VIBRATOR**

With the diesel engine running, turning the vibrator switch on the control pendant to the FORWARD position energizes the START SOLENOID on the start valve. The start valve directs hydraulic fluid to the motors and the motors start.

With the diesel engine running, turning the vibrator switch on the control pendant to the REVERSE position de-energizes the START SOLENOID. Fluid no longer is directed to the motors and they stop.

### **D. OTHER**

With the MAIN POWER switch ON, the TEMPERATURE SWITCH turns on the HYDRAULIC FLUID COLD LIGHT if the temperature of the hydraulic fluid in the reservoir is below 60°F. At 60°F or above, the TEMPERATURE SWITCH turns off the HYDRAULIC FLUID COLD LIGHT and energizes the COOLER VALVE solenoid. The cooler valve directs hydraulic fluid through the oil cooler.



**MODEL 416  
VIBRATORY  
DRIVER/EXTRACTOR**

# OPERATING INSTRUCTIONS

VI. ELECTRICAL CIRCUITRY

ELECTRICAL SCHEMATIC - 250

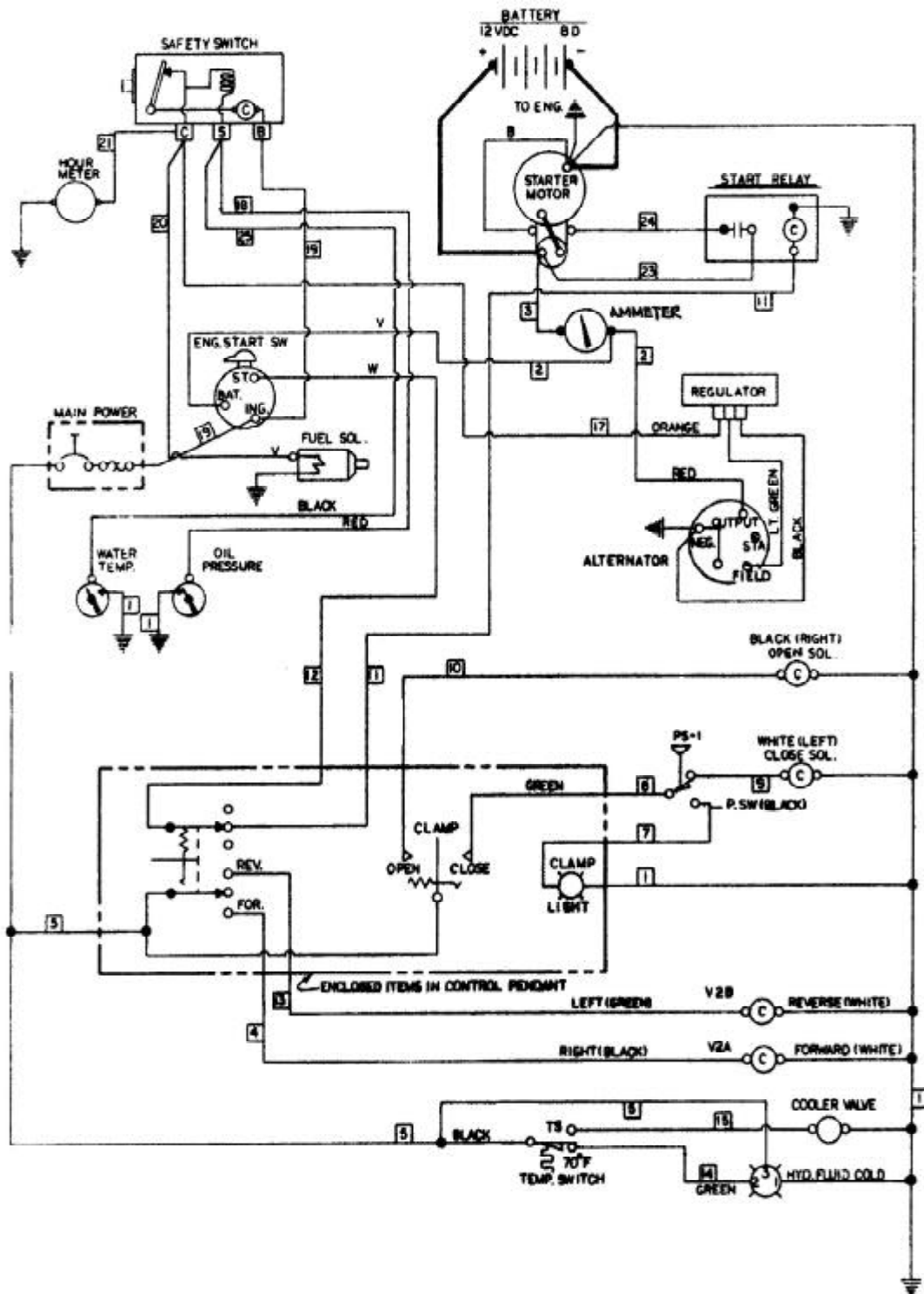



MODEL 416  
VIBRATORY  
DRIVER/EXTRACTOR

# OPERATING INSTRUCTIONS

## VI. ELECTRICAL CIRCUITRY

### E. ELECTRICAL COMPONENTS LIST

Notation	Reference	Part Number	Page Ref.
AMMETER	Ammeter	110371	VII-27
BATTERY	12-Volt Battery	100529	VII-19
CLAMP LIGHT	Clamp Light	130085	VII-27
CLOSE SOL.	Close-Clamp Solenoid (Valve)	130033	VII-31
COOLER VALVE	Cooler Valve	100872	VII-31
ENG. START SW.	Engine Start Switch	130259	VII-27
FOR/REV	Vibrator Switch (FORWARD/REVERSE)	130155	VII-27
FUEL SOL.	Fuel Solenoid Valve	See Caterpillar	Parts Book
HOUR METER	Hour Meter	100343	VII-29
HYD. FLUID COLD	Hydraulic Fluid Warning Light	100355	VII-27
MAIN POWER	Main Power Circuit Breaker	400141	VII-27
OIL PRESSURE	Oil Pressure Gage	100329	VII-27
OPEN/CLOSE	Clamp Switch	130155	VII-27
OPEN SOL.	Open-Clamp Solenoid (Valve)	130033	VII-31
PS-1	Pressure Switch	810033	VII-31
REGULATOR	Regulator	See Caterpillar	Parts Book
SAFETY SWITCH	Safety Switch (Reset)	130257	VII-27
START	Vibrator Start Solenoid	130095	VII-25
STARTER MOTOR	Engine Starter	See Caterpillar	Parts Book
START RELAY	Engine Start Switch	See Caterpillar	Parts Book
TEMP. SWITCH	Temperature Switch	400115	VII-24
WATER TEMP.	Water Temperature Gage	130251	VII-27



**MODEL 416  
VIBRATORY  
DRIVER/EXTRACTOR**

**OPERATING  
INSTRUCTIONS**

VI. ELECTRICAL CIRCUITRY

ELECTRICAL DIAGRAM - 250

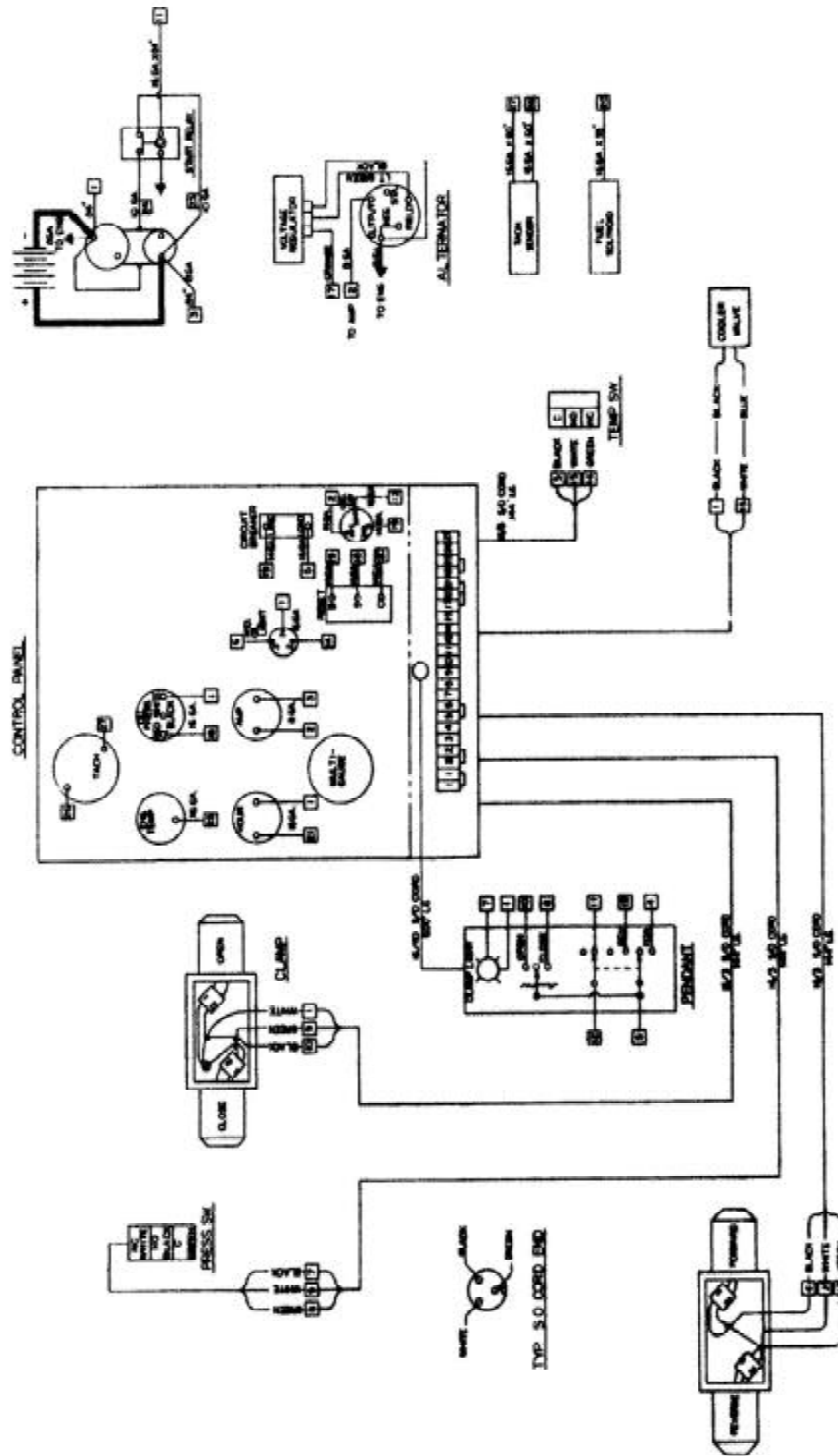



MODEL 416  
VIBRATORY  
DRIVER/EXTRACTOR

# PARTS LIST

## VII. GENERAL DATA

### A. ABBREVIATIONS

The abbreviations shown below are used throughout the parts lists and various other parts of the manual.

Assy.	Assembly
BHCS	Button Head Cap Screw
Cyl.	Cylinder
DC	Direct Current
FHCS	Flat Head Cap Screw
FLCS	Flanged Head Cap Screw
HC	High Collar
HHCS	Hex Head Cap Screw
HHPP	Hex Head Pipe Plug
HSSS	Hex Socket Set Screw
Hyd.	Hydraulic
Lg.	Long
mm	Millimeter
Mtg.	Mounting
NPT	National Pipe Thread
PHMS	Phillips Head Machine Screw
P/N	Part Number
Qty.	Quantity
RHMS	Round Head Machine Screw
Sch.	Schedule
SHCS	Socket Head Cap Screw
SHPP	Socket Head Pipe Plug
SHSS	Socket Head Shoulder Screw
S/N	Serial Number
Sol.	Solenoid

### B. SCREWS AND BOLTS

1. Practically all connections on the unit are made with socket head (Allen) cap screws. These high-strength screws are available at most industrial supply houses.
2. Screws and bolts are designated in the PARTS LIST in abbreviated form. (Refer to sub-section A, above for specific abbreviations). The information, in parenthesis, immediately following the bolt or screw designation shows the size as follows:

(1/2 - 13 x 1-1/2)	1/2" Diameter
	13 Threads Per Inch
	1-1/2" Length

3. Some screws or bolts require a specific torque when replacing. For identification of these bolts and a more thorough understanding of torque, refer to SECTION IV - BOLT TORQUE INFORMATION.



MODEL 416  
VIBRATORY  
DRIVER/EXTRACTOR

# PARTS LIST

## VII. GENERAL DATA

### C. SERIAL NUMBER LOCATIONS

1. The following ICE vibratory units are serial numbered separately:
  - a. vibrator
  - b. power unit
  - c. clamp heads
  - d. caisson beams
  - e. 90° clamp adapter
  
2. In addition to the serial number plate itself (on vibrators, power units and clamps), the serial number is stamped into each unit in one or more places as follows:
  - a. Vibrator stamped twice - once on top right side of suppressor housing, once on bottom lip of vibration case on right side of motors' side.
  - b. Power unit stamped twice - once on control panel side of unit at right corner of reservoir, once on subbase inside door below hex-key rack.
  - c. Model 125 universal clamp stamped twice - once between cylinder guard and pile guide, once above bolts for key.
  - d. Model 127 Z-Pile clamp stamped twice - once in front of cylinder guard, once in back opening of pile guide.
  - e. Model 80 caisson clamp stamped twice - once by the lifting eye, once by the adjusting screw.
  - f. Caisson beams stamped twice - once on top center, once in center of both sides of flange.
  - g. 90° clamp plate stamped twice - once on top center, once on side.





MODEL 416  
VIBRATORY  
DRIVER/EXTRACTOR

# PARTS LIST

## VIII. ORDERING PARTS

### A. PROCEDURE

1. When ordering parts, be sure to include the model and serial number of the unit or component. The serial number may be located by referring to SECTION VII, SERIAL NUMBER LOCATIONS. Confirm all telephone orders immediately to avoid duplicating shipment.
2. ORIGINAL EQUIPMENT; Where serial numbers are given, these apply only to equipment and components originally furnished with the unit. Where equipment has been changed or added to, these numbers may not necessarily apply.
3. SHIPMENT; State to whom shipment is to be made and method of shipment desired, otherwise our own judgment will be used.
4. SHORTAGES; Claims for shortages or errors should be made immediately upon receipt of parts. No responsibility will be assumed for delay, damage or loss of material while in transit. Broken, damaged or lost material should be refused or a full description made of damage or loss to the carrier agent on the freight or express bill.
5. RETURN OF PARTS; If for any reason you desire to return parts to the factory or to any distributor from whom these parts were obtained, you must first secure permission to return the parts. Shipping instructions will be given along with this permission. A ten percent handling charge must be assessed against the returned shipment unless an error is made by the factory or by the distributor when filling your order.



**MODEL 416  
VIBRATORY  
DRIVER/EXTRACTOR**

# PARTS LIST

## VIII. ORDERING PARTS

### B. FITTING DESCRIPTION KEY

**F I T T 2 L - 1 6 M 1 2 J 0 0 0 - 0 0 L 0 0 0 1**

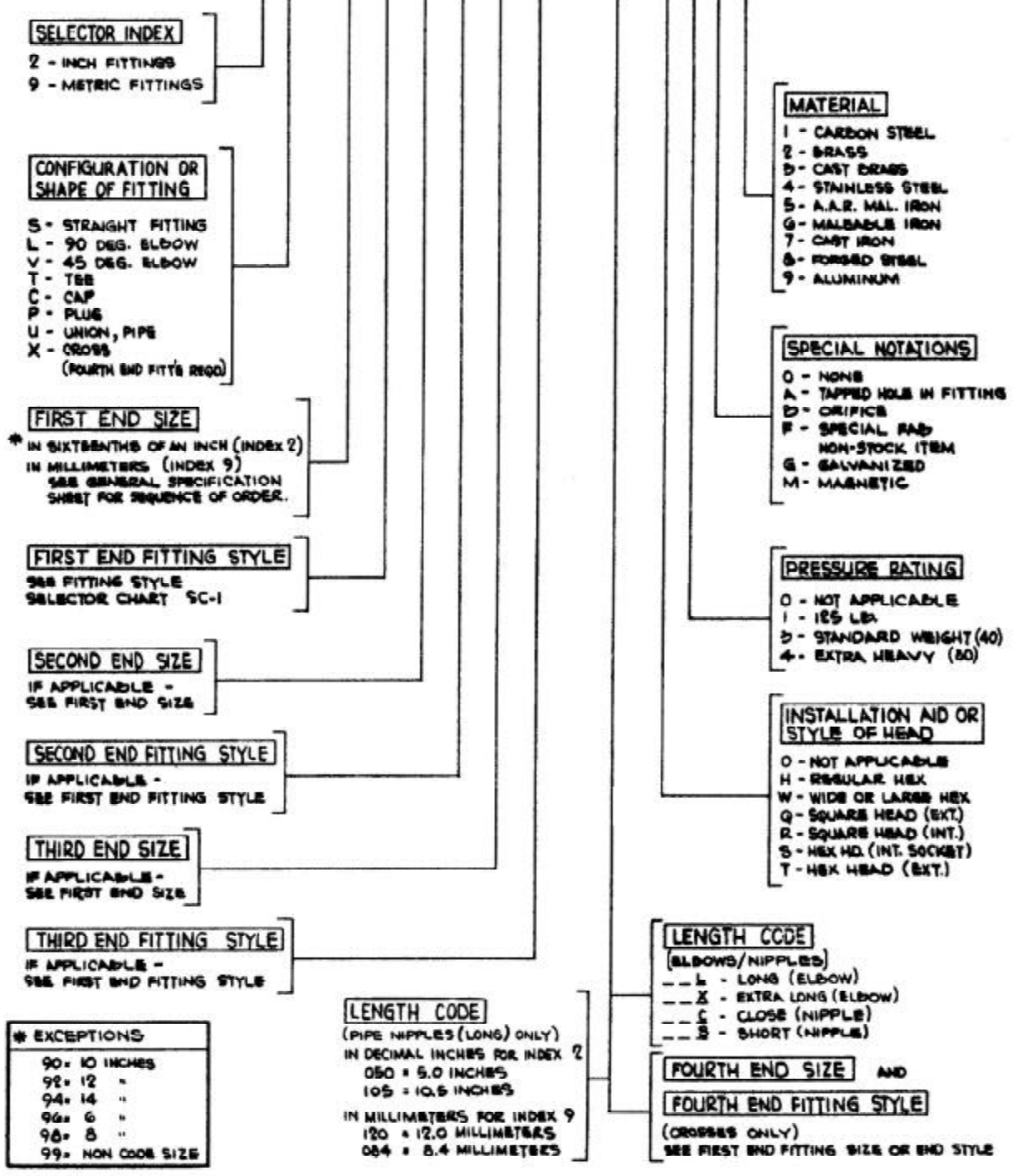



MODEL 416  
VIBRATORY  
DRIVER/EXTRACTOR

# PARTS LIST















VIII. ORDERING PARTS

B. FITTING DESCRIPTION KEY (CONTINUED)

## FITTING STYLE SELECTOR CHART

SC-1

FOR END FITTING STYLE SELECTION

M		JIC MALE 37° FLARE	J		JIC FEMALE 37° FLARE ( $\Phi$ SWIVEL)
P		MALE PIPE NPTF	Q		FEMALE PIPE NPTF
R		S.A.E. MALE O-RING ( $\Phi$ ADJUSTABLE)	K		S.A.E. FEMALE O-RING
B		JIC MALE 37° FLARE BULKHEAD	N		FEMALE PIPE NPSM - SWIVEL
D		MALE PIPE NPTF - SWIVEL	E		COMPRESSION FITTING FLARELESS (WEATHERHEAD)
S		B.S.P. MALE PIPE	I		COMPRESSION FITTING FLARELESS (IMPERIAL EASTMAN)
F		SPLIT FLANGE STANDARD PRESSURE CODE 01			
H		SPLIT FLANGE HI PRESSURE CODE 02			



**MODEL 416  
VIBRATORY  
DRIVER/EXTRACTOR**

# PARTS LIST

VIII. ORDERING PARTS

C. HOSE DESCRIPTION CODE

The HOSE DESCRIPTION CODE is a 24 digit number enabling easier and quicker identification whenever a hose replacement is desired. The key below explains the structure of the coded number in detail.

**HOSE 125 R11 F9 24 P0 20 L0395 S**

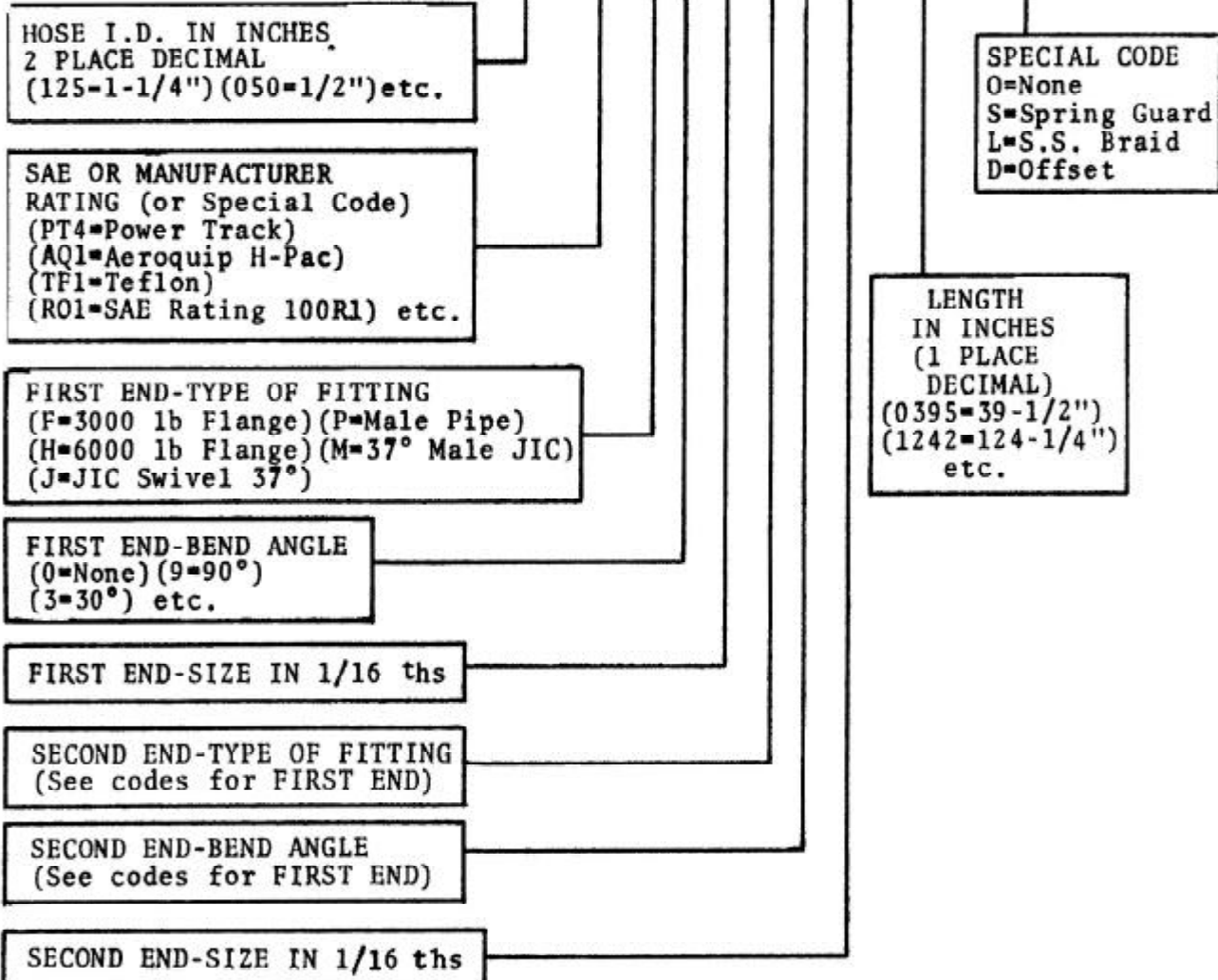



**MODEL 416  
VIBRATORY  
DRIVER/EXTRACTOR**

# **PARTS LIST**

## VIII. ORDERING PARTS

### D. PARTS IDENTIFICATION

1. Parts lists and drawings are included on the following pages for the equipment components shown below:

a.	VIBRATION SUPPRESSOR	800027
b.	VIBRATION CASE	810037
c.	HOSE ASSEMBLIES - INTERCONNECTING	800029
d.	DISTRIBUTION BLOCK	810041
e.	POWER UNIT - ENCLOSURE	800249
f.	POWER UNIT - INTERNAL	800239
g.	CONTROL BOX	810345
h.	CONTROL MANIFOLD ASSEMBLY	810353
i.	MODEL 125 UNIVERSAL CLAMP	800039
j.	POWER UNIT - SILENCER GROUP	800251
k.	MODEL 127 Z-PILE CLAMP	800041
l.	MODEL 80 CAISSON CLAMP	800047
m.	CAISSON BEAM - 7 FOOT	800045
n.	CLAMP EXTENSION - 8 FOOT	800063
o.	90° CLAMP ADAPTER	800049

2. The spare parts list SECTION VIII - RECOMMENDED SPARE PARTS contains spare parts which may be very useful in keeping down-time to a minimum, especially in remote or secluded jobsites where unforeseen communication problems could cause delay of the delivery of an awaited part.

These RECOMMENDED SPARE PARTS may be ordered beforehand, individually or as a package group as shown in the PARTS LIST.



MODEL 416  
VIBRATORY  
DRIVER/EXTRACTOR

# PARTS LIST

VIBRATION SUPPRESSOR

800027

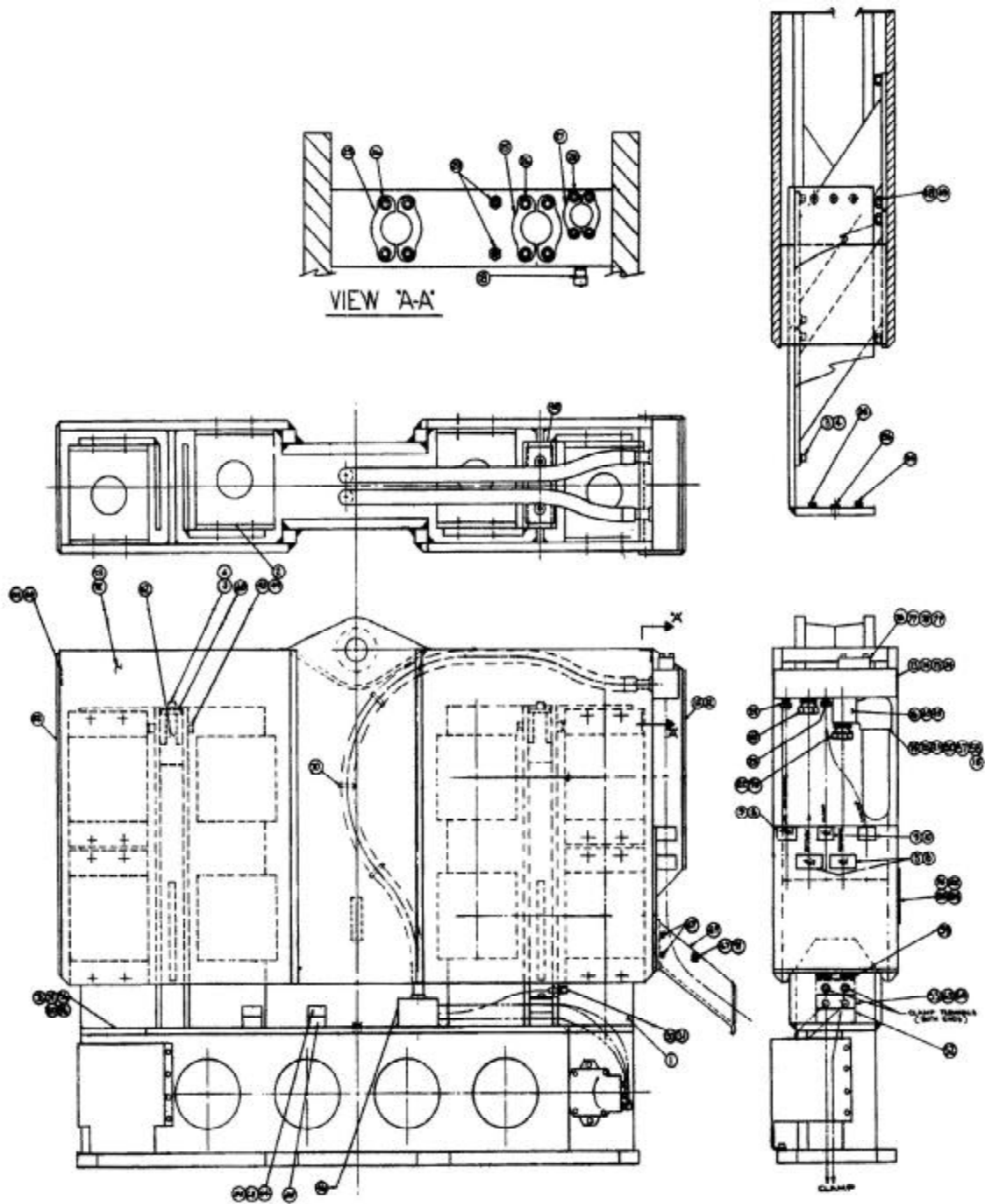



MODEL 416  
VIBRATORY  
DRIVER/EXTRACTOR

# PARTS LIST

VIBRATION SUPPRESSOR

800027

Item	Part Number	Qty.	Description
1	100002	1	Transmission Case Adapter
2	100003	8	Elastomer
3	100005	42	SHCS (5/8-11 x 1-3/4)
4	100007	58	Lockwasher (5/8)
5	100009	2	Hose Clamp
6	100011	6	SHCS (1/2-13 x 2)
7	100013	1	Hose Clamp
9	100015	2	Hose Clamp
10	100017	4	SHCS (3/8-16 x 2)
11	100019	1	Coupler Guard
12	100021	4	FHCS (1/2-13 x 1-1/2)
13	100789	1	Terminal Manifold Note 1
	110283	1	Terminal Manifold Note 2
	110733	1	Terminal Manifold Note 3
14	100025	4	SHCS (1/2-13 x 4-1/2)
15	100027	12	Lockwasher (1/2 High Collar)
16	110273	1	Manifold Block
18	100032	1	Relief Valve (RV3)
19	100971	1	Filter (F3)
20	100035	1	Extra Element
21	100037	2	O-Ring (#222)
22	100039	1	FITT2S-20P20N000-000H001
23	100041	2	FITT2S-06P06N000-000H001
24	100043	1	FITT2S-12P12N000-000H001
25	100596	4	Split Flange Half
26	100119	8	SHCS (1/2-13 x 1-1/4)
27	100049	2	Split Flange Half
28	100051	4	SHCS (3/8-16 x 1)
29	100053	2	FITT2S-06M06R000-000H001
30	100055	4	FITT2S-06M06B000-000H001
31	100057	4	FITT2C-06J000000-000H001
32	100059	1	Suppressor Housing
34	100063	3	FITT2P-16P000000-000S007
36	100067	14	SHCS (3/4-10 x 2-1/2)
37	100069	14	Lockwasher (3/4)
40	100071	22	SHCS (5/8-11 x 2-1/2)

Note 1: Required on units with S/N up to 170723.

Note 2: Required on units with S/N 170724 up to and including 180730.

Note 3: Required on units with S/N 180731 and above.



MODEL 416  
VIBRATORY  
DRIVER/EXTRACTOR

# PARTS LIST

VIBRATION SUPPRESSOR (CONTINUED)

800027

Item	Part Number	Qty.	Description
42	100074	2	Stop Block
43	100773	6	SHCS (5/8-11 x 4-1/4)
46	810041	1	Distribution Block
48	100085	32	SHCS (5/8-11 x 2-1/4)
49	100086	38	Hex Nut (5/8 - 11 ESNA)
50	100084	4	SHCS (1/2-13 x 5)
52	100817	2	Double Hose Clamp
53	100819	2	Adapter Bracket
54	100821	2	Gang Hose Clamp
55	100823	2	Adapter Bracket
57	110215	1	O-Ring (#239)
58	110217	1	Back-Up Ring (#239)
59	100905	1	Label Group
60	100829	4	SHCS (1/2-13 x 3-1/2)
63	100827	10	SHCS (3/8-16 x 3-1/2)
64	400149	10	Lockwasher (3/8)
65	110115	1	FITT2S-24P24N000-000H001
67	100575	6	SHCS (5/8-11 x 1-1/4)
68	100915	4	Stop Block Plate
69	110381	1	Hose Guide
70	130243	11	Hose Tie-Down
71	110383	1	Hose Guide Rod
74	400277	2	Logo Plate
75	400159	1	FITT2S-24P20Q000-000H001
76	110723	1	Check Body
77	110731	1	Check Valve (CV6)
78	100735	4	SHCS (1/2-13 x 2-1/2)
79	100097	2	O-Ring (#214)
82	110745	2	"4" Logo Plate
83	100629	2	"1" Logo Plate
84	100747	2	"6" Logo Plate
85	130381	8	Rivet
86	100423	1	FITT2P-08P000000-000S007





**MODEL 416  
VIBRATORY  
DRIVER/EXTRACTOR**

# PARTS LIST

VIBRATION CASE

810037

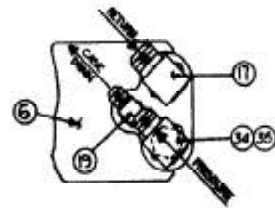

VIEW A-A

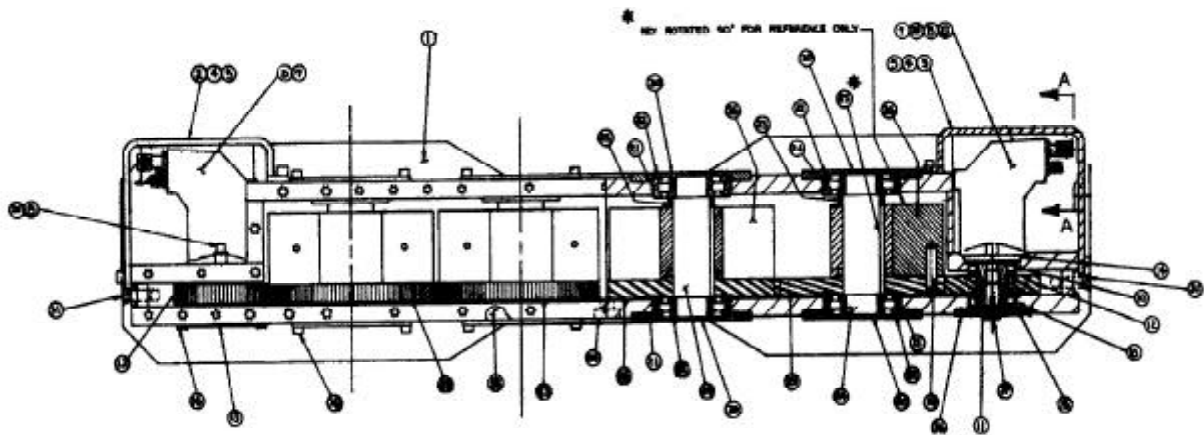

**\* Item 25 (Key) is required only on units  
with S/N up to and including 180797.**



MODEL 416  
VIBRATORY  
DRIVER/EXTRACTOR

# PARTS LIST

VIBRATION CASE

810037

Item	Number	Qty.	Description
1	810051	1	Vibration Case Frame
2	100763	1	Motor Guard - Right
3	100765	1	Motor Guard - Left
4	100119	68	SHCS (1/2-13 x 1-1/4)
5	100121	20	Lockwasher (1/2)
6	100779	2	Motor (M)
7	100903	2	O-Ring Plug (#8)
8	100005	4	SHCS (5/8-11 x 1-3/4)
10	100161	4	Roller Bearing
11	100755	2	Motor Gear Shaft
12	100739	2	Motor Gear
13	100757	1	Bearing Housing
14	110197	2	Motor O-Ring (#159)
15	100781	2	Bearing O-Ring (#156)
16	100445	8	SHCS (1/2 - 13 x 1)
17	100783	2	FITT2L-16M16R000-000H001
19	100787	2	FITT2L-08M08R000-000H001
20	100165	8	Bearing Cover
21	100167	8	O-Ring (#266)
22	100169	8	Roller Bearing
23	100171	4	Spacer
24	150003	4	Eccentric Shaft (Note 1)
	100173	4	Eccentric Shaft (Note 2)
25	100177	4	Key (Note 3)
26	100175	4	Eccentric
27	150005	2	Drive Gear (Note 1)
	100741	2	Drive Gear (Note 2)
28	150007	2	Drive Gear (Note 1)
	100759	2	Drive Gear (Note 2)
30	100185	1	Sight Gauge
31	100187	2	FITT2P-12P000000-000SOM7
32	100720	1	Gasket
34	100769	2	FITT2L-12M12J000-000H001
35	100847	2	FITT2S-16R12M000-000H001
36	100985	1	Bearing Housing
37	810229	1	Centrifugal Breather
38	150173	4	Drive Pin
39	130261	4	5/8 Hi-Collar Lockwasher

Note 1 - Required on units with serial number 180798 and above.

Note 2 - Required on units with serial number up to and including 180797.

Note 3 - Required on units with serial number up to and including 180797 only. Not used after that.



**MODEL 416  
VIBRATORY  
DRIVER/EXTRACTOR**

# PARTS LIST

**HOSE ASSEMBLIES - INTERCONNECTING**

**800029**

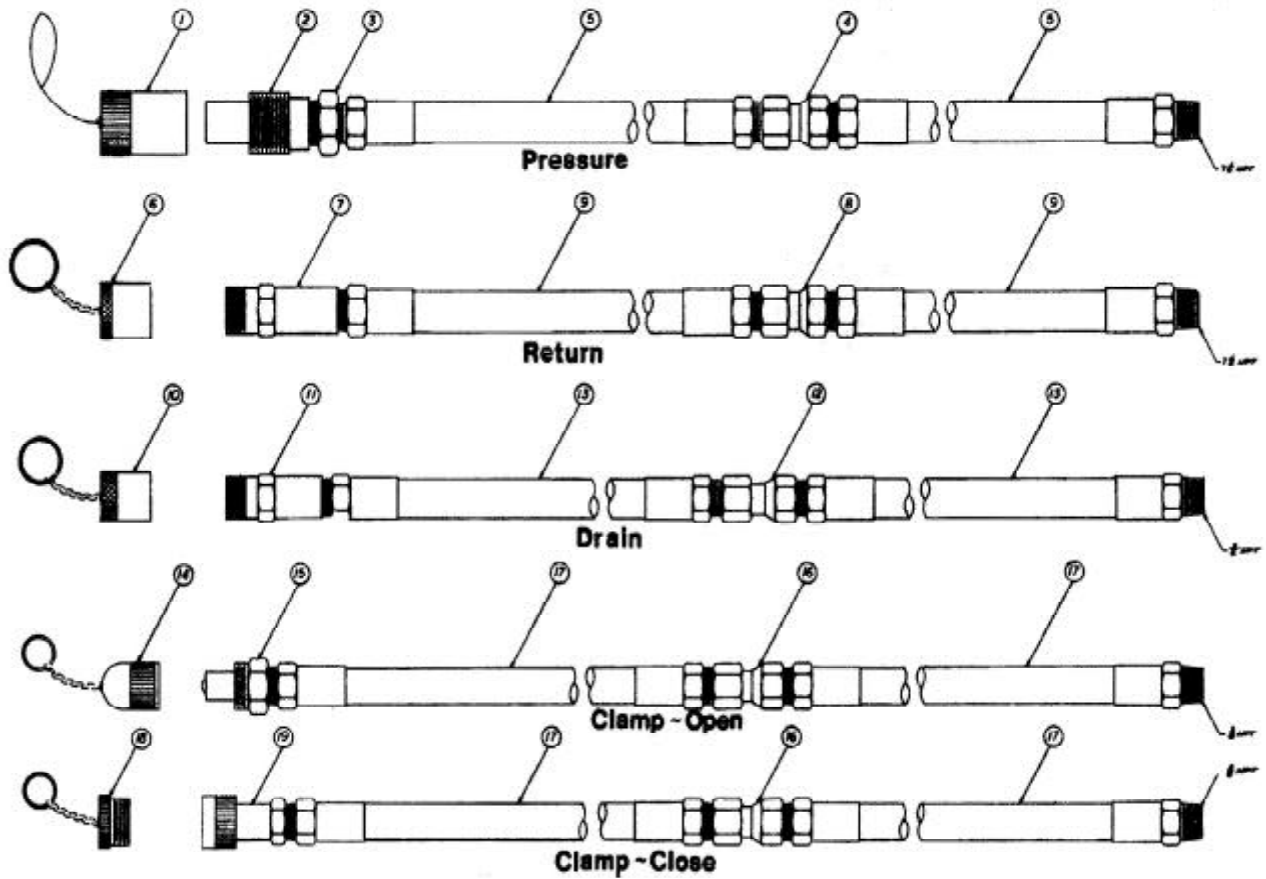



MODEL 416  
VIBRATORY  
DRIVER/EXTRACTOR

# PARTS LIST

HOSE ASSEMBLIES - INTERCONNECTING

800029

Item	Part Number	Qty.	Description
1	110955	1	Dust Cap (1-1/2)
2	110690	1	Male Disconnect (1-1/2) Note 1
	110951	1	Male Disconnect (1-1/2) Note 2
3	400159	1	FITT2S-24P20Q000-000H001
4	100235	1	FITT2S-20Q20N000-000H001
5	100233	2	HOSE125R10P020P020L60000
6	100893	1	Dust Cap (1-1/2)
7	100897	1	Male Disconnect (1-1/2)
8	110139	1	FITT2S-24Q24N000-000H001
9	100911	2	HOSE150R02P024P024L60000
10	400253	1	Dust Cap (3/4)
11	400251	1	Male Disconnect (3/4)
12	100243	1	FITT2S-12Q12N000-000H001
13	100241	2	HOSE075R02P012P012L62000
14	100257	1	Dust Cap (3/8)
15	100245	1	Male Disconnect (3/8)
16	100249	2	FITT2S-06Q06N000-000H001
17	100247	4	HOSE038R02P006P006L62000
18	100737	1	Dust Plug (3/8)
19	100777	1	Female Disconnect (3/8)
	130243	10	Rubber Tie Down

Note 1: Required on units with serial number 182800 and above.

Note 2: Required on units with serial number up to and including 182799. Check valve replacement kit part number 850067 is offered to convert existing units to accept newer design coupler on power unit. See page VIII-46.



**MODEL 416  
VIBRATORY  
DRIVER/EXTRACTOR**

# PARTS LIST

**DISTRIBUTION BLOCK**

**810041**

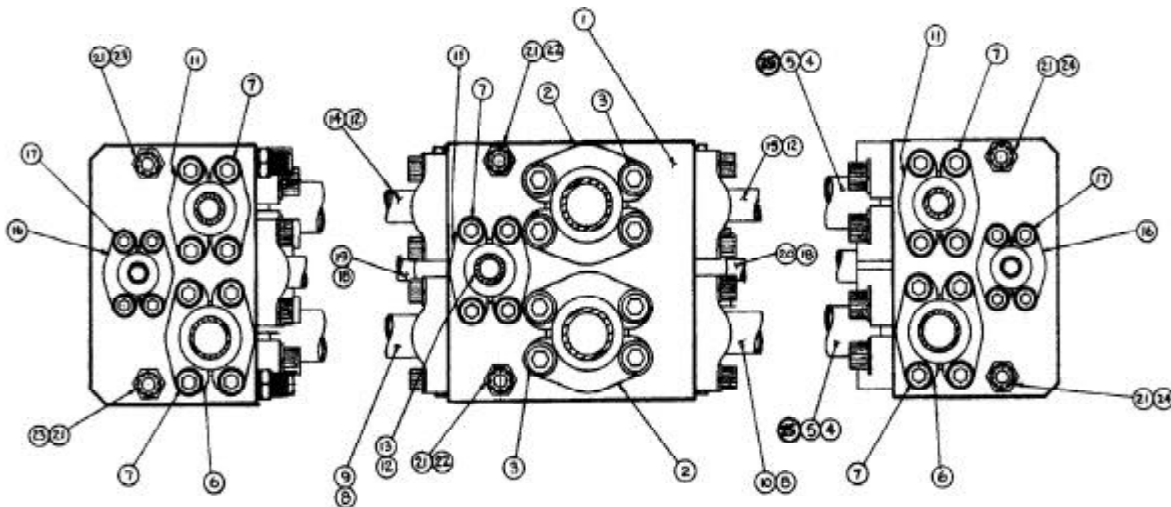

LEFT

TOP

RIGHT

**VIEWED FROM MOTOR SIDE OF VIBRATOR**



MODEL 416  
VIBRATORY  
DRIVER/EXTRACTOR

# PARTS LIST

DISTRIBUTION BLOCK

810041

Item	Part Number	Qty.	Description
1	100081	1	Distribution Manifold
2	100045	4	Split Flange Half (1-1/4)
3	100047	8	SHCS (7/16 - 14 x 1)
4	100037	2	O-Ring (#222)
5	100969	2	HOSE125R10F020F024L0875S
6	100089	4	Split Flange Half (1)
7	100051	20	SHCS (3/8 - 16 x 1)
8	100091	2	O-Ring (#219)
9	100843	1	HOSE100R01J016F016L0545S
10	100841	1	HOSE100R01J016F016L0370S
11	100049	6	Split Flange Half (3/4)
12	100097	3	O-Ring (#214)
13	100099	1	HOSE075R02F012F012L0880S
14	100839	1	HOSE075R10J012F012L0580S
15	100837	1	HOSE075R10J012F012L0400S
16	100103	4	Split Flange Half (1/2)
17	100105	8	SHCS (5/16 - 18 x 1)
18	100107	2	O-Ring (#210)
19	100835	1	HOSE050R01J008F008L0525S
20	100833	1	HOSE050R01J008F008L0350S
21	100053	6	FITT2S-06M06R000-000H001
22	100111	2	HOSE038R02J006J006L0875S
23	110633	2	HOSE038R02J006J006L0370S
24	100108	2	HOSE038R02J006J006L0200S
25	100119	2	O-Ring (#225)



MODEL 416  
VIBRATORY  
DRIVER/EXTRACTOR

# PARTS LIST

POWER UNIT - ENCLOSURE - 250

800249

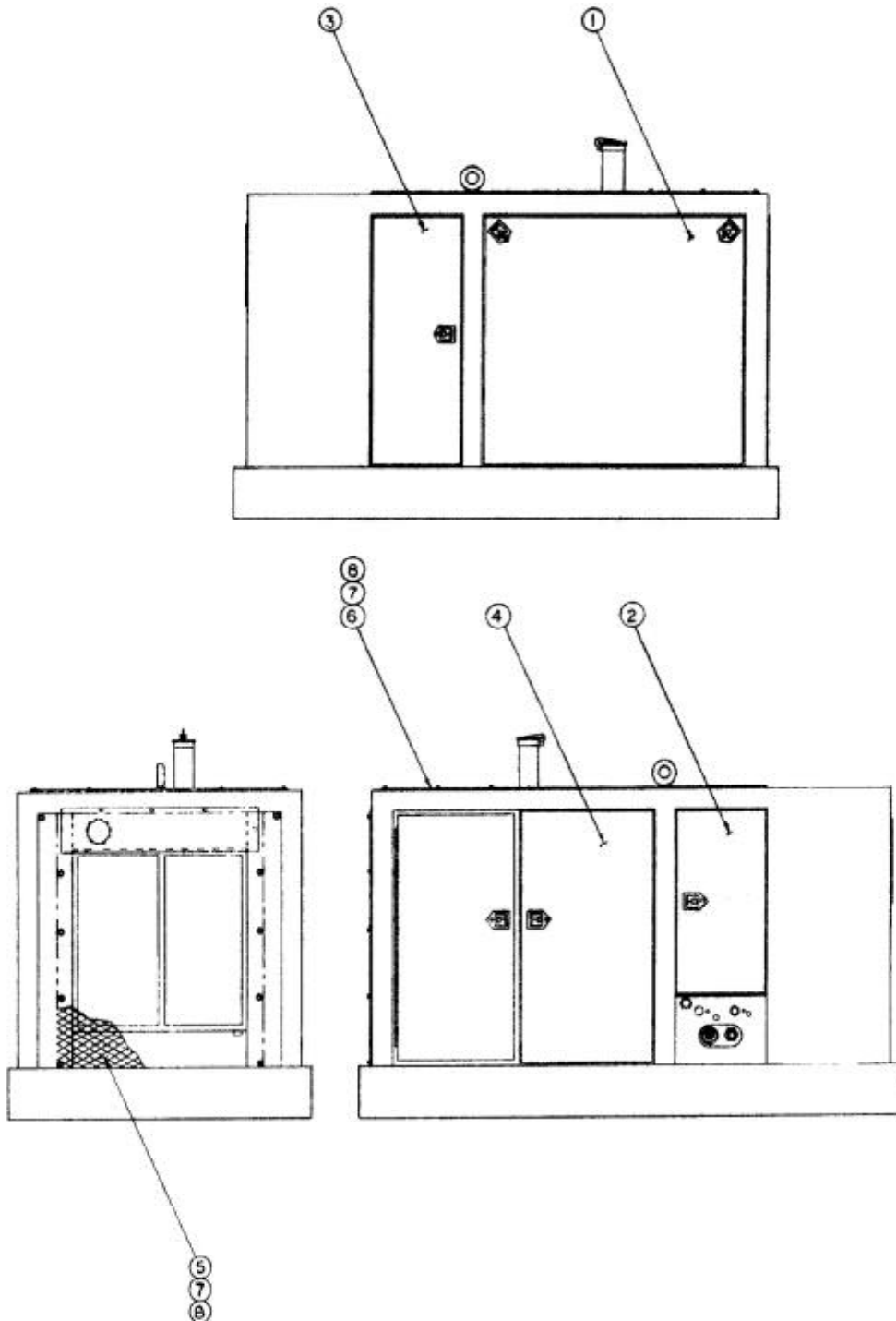



MODEL 416  
VIBRATORY  
DRIVER/EXTRACTOR

# PARTS LIST

POWER UNIT - ENCLOSURE

800249

<u>Item</u>	<u>Part Number</u>	<u>Qty.</u>	<u>Description</u>
1	100901	1	Cover Door
2	100896	1	Cover Door
3	100867	1	Cover Door
4	100869	1	Cover Door
5	810333	1	Intake Grill
6	810331	1	Exhaust Grill
7	130209	27	Hex Screw (1/4 x 5/8)
8	130227	27	Fender Washer (1/4")





**MODEL 416  
VIBRATORY  
DRIVER/EXTRACTOR**

# PARTS LIST

250 POWER UNIT - INTERNAL

800239

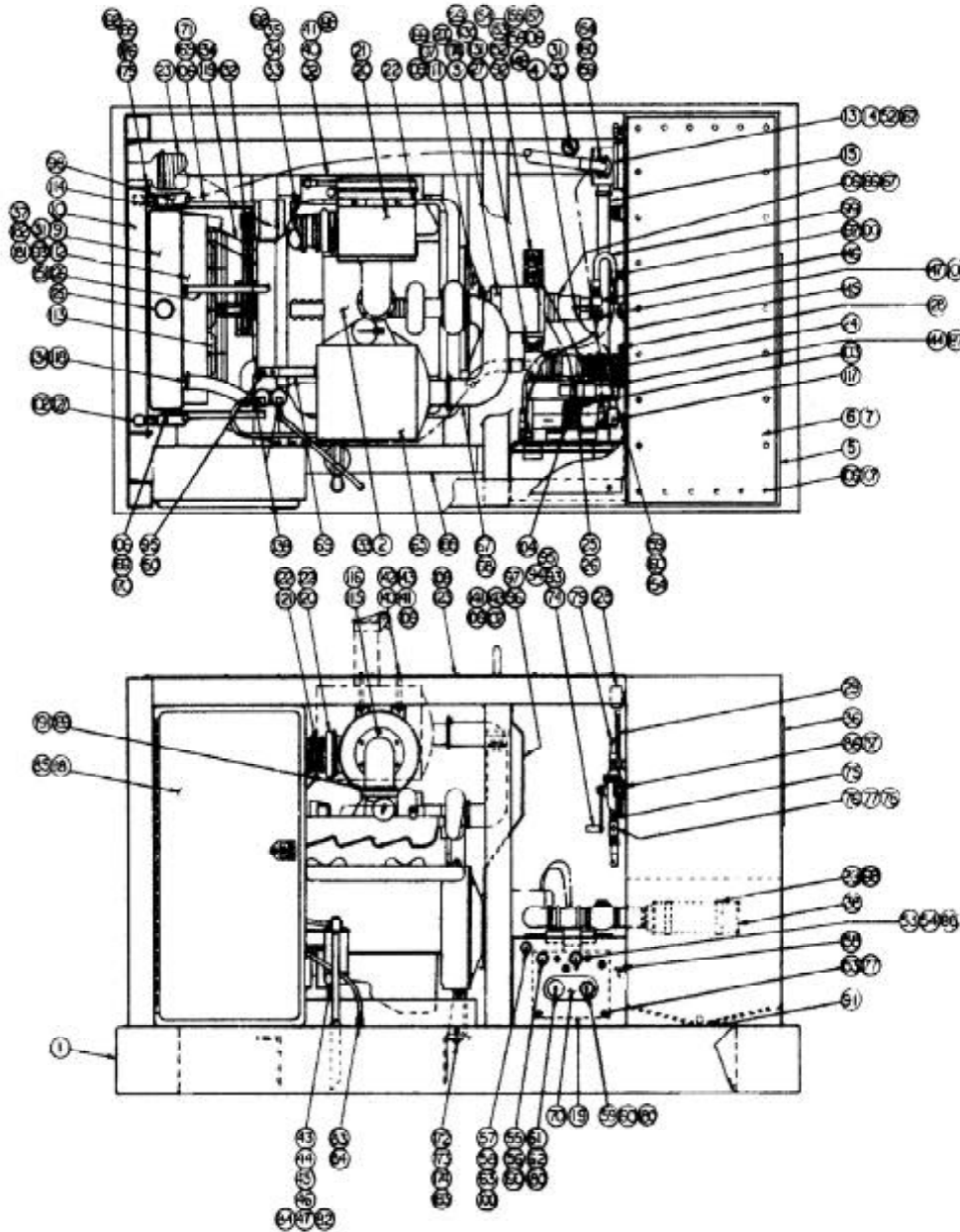

For view of power unit front elevation  
and return filter detail see page VIII-21.



**MODEL 416  
VIBRATORY  
DRIVER/EXTRACTOR**

# PARTS LIST

250 POWER UNIT - INTERNAL

800239

Item	Part Number	Qty.	Description
1	810341	1	Sub-base Assembly
2	100944	1	Diesel Engine (E)
3	100894	1	Drive Pump (P1)
4	100892	1	Clamp Pump (P2)
5	130109	1	Reservoir
6	400129	1	Reservoir Cover
7	400225	1	Reservoir Cover Gasket
8	100984	1	Radiator Support
9	100956	1	Radiator
10	400099	1	Heat Exchanger (HE)
11	100873	1	Cooler Bracket R. H.
12	100979	1	Cooler Bracket L. H.
13	100583	1	Return Filter (F2, CV3)
14	810117	2	Filter Element (K10)
15	100918	27	1-1/2 Steel Tube
16	100952	1	1-1/2 Flex Master - 90°
18	810345	1	Control Box
19	100992	1	Coupler Panel
20	100950	1	Filter Assembly
21	100912	1	Air Cleaner Element
22	100948	1	Air Cleaner Bracket
23	100951	1	Flexhaust
24	400117	1	2-1/2 Stop Cock
25	100709	1	Flex Master - 2-1/2"
26	100888	2	FITT2S-40P40P000-0370306
27	100962	1	FITT2L-32P32Q000-0000306
28	100455	1	Breather
29	130179	1	Sight Gage/Thermometer
30	100417	1	FITT2C-48Q000000-0000306
31	100419	2	Fuel Vent
32	100529	1	Battery
33	810167	1	Battery Hold-Down
34	400231	2	Hold-Down Stud
35	100831	2	Wing-Nut (5/16)
36	400277	1	Logo Plate
37	100916	8	Rivnuts
38	400087	1	Pick-Up Filter (F1)
39	400445	2	Flex-Wrap Magnet
40	100537	1	Battery Cable - 23
41	110755	1	Battery Cable - 15
42	100981	1	Top Cooler Guard
43	120423	1	Water Separator
44	120425	1	FITT2S-16P16P000-1000301
45	100715	1	FITT2S-16P06Q000-000H001



**MODEL 416  
VIBRATORY  
DRIVER/EXTRACTOR**

**PARTS LIST**

250 POWER UNIT - INTERNAL

800239

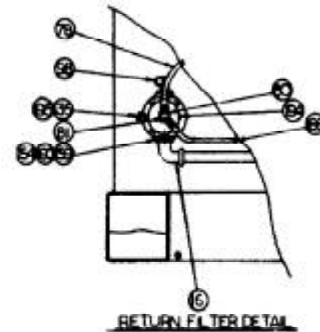
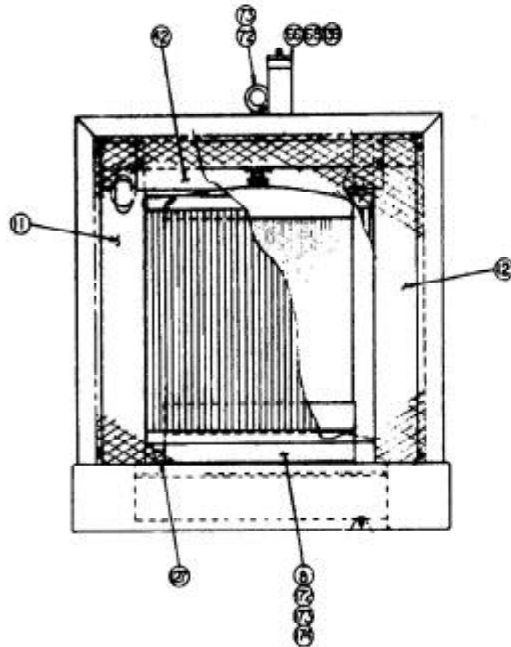

For side elevation and top view of power unit, see page VIII-18.

Item	Part Number	Qty.	Description
46	400227	1	FITT2L-06M06P000-0000001
47	110377	1	FITT2L-16P16Q000-0000306
52	110511	4	Seal Washer
53	100777	1	Female Disconnect (3/8) QD3
54	100737	1	Dust Plug (3/8)
55	100245	1	Male Disconnect (3/8) QD4
56	100257	1	Dust Cap (3/8)
57	400095	1	Female Disconnect (3/4) QD5
58	400121	1	Dust Plug (3/4)
59	100891	1	Female Disconnect (1-1/2) QD1
60	100895	1	Dust Plug (1-1/2)
61	110692	1	Female Disconnect (1-1/2) QD2 Note 1
	110953	1	Female Disconnect (1-1/2) QD2 Note 2
62	100895	1	Dust Plug (1-1/2)
63	100387	1	FITT2S-12P12B000-000H001

Note 1: Required on units with serial number 182800 and above.

Note 2: Required on units with S/N up to and including 182799. Check valve replacement kit P/N 850067 is offered to convert P/N 110953 to accept new coupler on interconnecting hose. See pg VIII-46.



MODEL 416  
VIBRATORY  
DRIVER/EXTRACTOR

# PARTS LIST

250 POWER UNIT - INTERNAL

800239

Item	Part Number	Qty.	Description
65	100964	1	Spiral Silencer
66	100958	1	Exhaust Extension
67	100940	1	Exhaust Elbow
68	400267	2	Exhaust Clamps
69	100942	1	Silencer Bracket
70	810353	1	Control Manifold Assembly
72	100460	1	Eye Bolt with Nut
73	100722	1	Roll Pin
74	100447	1	Manual Pump (MP)
75	100449	1	FITT2S-16P16P000-000H001
76	100451	1	Check Valve (CV4)
77	100453	1	FITT2S-16P12Q000-000H001
78	400217	1	HOSE075R01P012J012L01800
79	400215	1	HOSE100R01P016P016L08400
80	100771	1	FITT2T-12M12R12M-000H001
81	100769	1	FITT2L-12M12J000-000H001
82	110819	1	Suction Filter Tube
83	110171	1	FITT2S-08P06M000-000H001
84	130389	2	Fuel Suction Line
85	100651	1	Test Light
86	810045	1	Hex Key Group
87	100600	1	Hex Key Rack
88	130203	1	FITT2S-06P06P000-0300401
91	100423	4	FITT2P-08P000000-000S007
92	100999	1	Port Adapter
93	100439	2	SHCS (7/16 - 14 x 1-3/4)
94	400153	2	Flatwasher (7/16)
95	100443	4	Lockwasher (7/16)
96	100988	1	Baffle L. H.
97	100986	1	Baffle R. H.
98	100947	1	HOSE150P01P024F924L07700
99	100932	1	HOSE100R01J016J016L05500
100	300115	1	HOSE075R01J012J012L02600
101	100928	1	HOSE050R09J008J008L02200
102	100926	1	HOSE150R02P024F924L09300
103	100924	1	HOSE100PT4F016F016L06000
104	100922	1	HOSE100PT4F016F016L04700
106	400149	42	Lockwasher (3/8)
107	100648	28	SHCS (3/8 - 16 x 7/8)
108	130209	31	Hex Tek (1/4 - 14 x 5/8)



**MODEL 416  
VIBRATORY  
DRIVER/EXTRACTOR**

# PARTS LIST

250 POWER UNIT - INTERNAL

800239

Item	Part Number	Qty.	Description
109	130227	15	Fender Washer (1/4)
110	100875	1	Intake Grill
111	810343	1	Pump Drive Assembly
112	100842	1	Fan Shroud
113	100953	1	Fan
114	100840	1	Fan Cage
115	100968	1	Intake Elbow
116	100970	1	Intake Flange
117	400115	1	Temperature Switch (TS)
118	150117	1	Top Radiator Hose
119	100955	1	Lower Radiator Hose
120	100904	1	Air Duct Reducer
121	100886	1	Sleeve
122	130237	4	Hose Clamp
123	100906	1	Top Unit Cover
125	100884	1	Radiator Cap
126	100882	1	Shunt Line Hose
127	400147	2	FITT2L-24P24Q000-0000406
128	100183	1	FITT2P-12P000000-000S007
129	100946	1	MFP Flange
130	100513	8	SHCS (1/2 - 13 x 1-1/2)
131	100027	4	Lockwasher (1/2) H. C.
132	810301	1	Tachometer Transmitter
133	130309	1	Throttle Bracket
134	110963	6	Radiator Hose Clamp
135	100775	1	Indicator Gage (GA4)
138	300197	2	FITT2L-04P04Q000-0000306
139	100890	1	Rain Cap
140	100227	2	SHCS (3/8 - 16 x 2-1/4)
141	100535	4	Hex Nut (3/8 - 16)
142	100880	2	Pipe (3/8" x 1-1/2)
143	400151	4	Flatwasher (3/8)
144	100717	1	FITT2L-06P04M000-0000001
145	120055	1	FITT2L-16M16P000-0000001
146	100938	1	FITT2L-16M12R000-000H001
147	110211	1	FITT2L-12R08M000-000H001
148	100936	1	FITT2S-06M04R000-000H001
149	100489	1	FITT2L-12M12P000-0000001
150	100851	2	SHCS (7/16 - 14 x 1-1/4)
151	100876	2	Hose Clamps



**MODEL 416  
VIBRATORY  
DRIVER/EXTRACTOR**

# PARTS LIST

250 POWER UNIT - INTERNAL

800239

Item	Part Number	Qty.	Description
152	100874	4	SHCS (1/2 - 13 x 5-3/4)
153	100121	16	Lockwasher (1/2)
154	110119	4	O-Ring (#225)
155	100051	8	SHCS (3/8 - 16 x 1)
156	100091	2	O-Ring (#219)
157	100089	4	Split Flange (#16)
158	100601	1	FITT2T-04M04P04M-0000001
159	100596	6	Split Flange (#24)
160	100445	12	SHCS (1/2 - 13 x 1)
166	100870	1	Clamp Pump Gasket
167	130117	6	SHCS (3/8 - 16 x 1-1/2)
169	400155	2	BHCS (3/8 - 16 x 3/4)
170	100910	1	Radiator Brace L. H.
171	100908	1	Radiator Brace R. H.
172	100273	6	Hex Nut (5/8 - 11)
173	130141	6	Flatwasher (5/8)
174	100007	6	Lockwasher (5/8)
175	100105	26	SHCS (5/16 - 18 x 1)
176	100287	26	Lockwasher (5/16)
177	100119	4	SHCS (1/2 - 13 x 1-1/4)
180	110037	2	FITT2S-24P24P000-000H001
181	100557	8	SHCS (1/4 - 20 x 3/4)
182	100559	8	Lockwasher (1/4)
183	130135	4	SHCS (5/8 - 11 x 3-1/2)
185	100289	14	Hex Nut (5/16 - 18)
186	100941	1	HOSE075R01J012J012L04400
187	100149	2	HOSE025R02J004J004L01900
188	400245	9	Wire Bundle Bracket
189	100866	1	Air Intake Adapter
190	110794	1	FITT2S-06P06P000-000H001
191	130407	1	Gasket - Air Intake
192	100293	22	Flatwasher (5/16)
193	100597	8	Flatwasher (1/4)
194	100646	1	FITT2P-02P000000-000S007
195	100825	1	FITT2S-04Q02P000-000W001
196	130095	1	Start Solenoid
197	400187	1	FITT2S-12M12P000-000H001
198	400173	1	FITT2S-48P40Q000-000H306
199	100143	12	SHCS (3/8 - 16 x 1-1/4)
200	100575	2	SHCS (5/8 - 11 x 1-1/4)



**MODEL 416  
VIBRATORY  
DRIVER/EXTRACTOR**

# PARTS LIST

CONTROL BOX - 250

810345

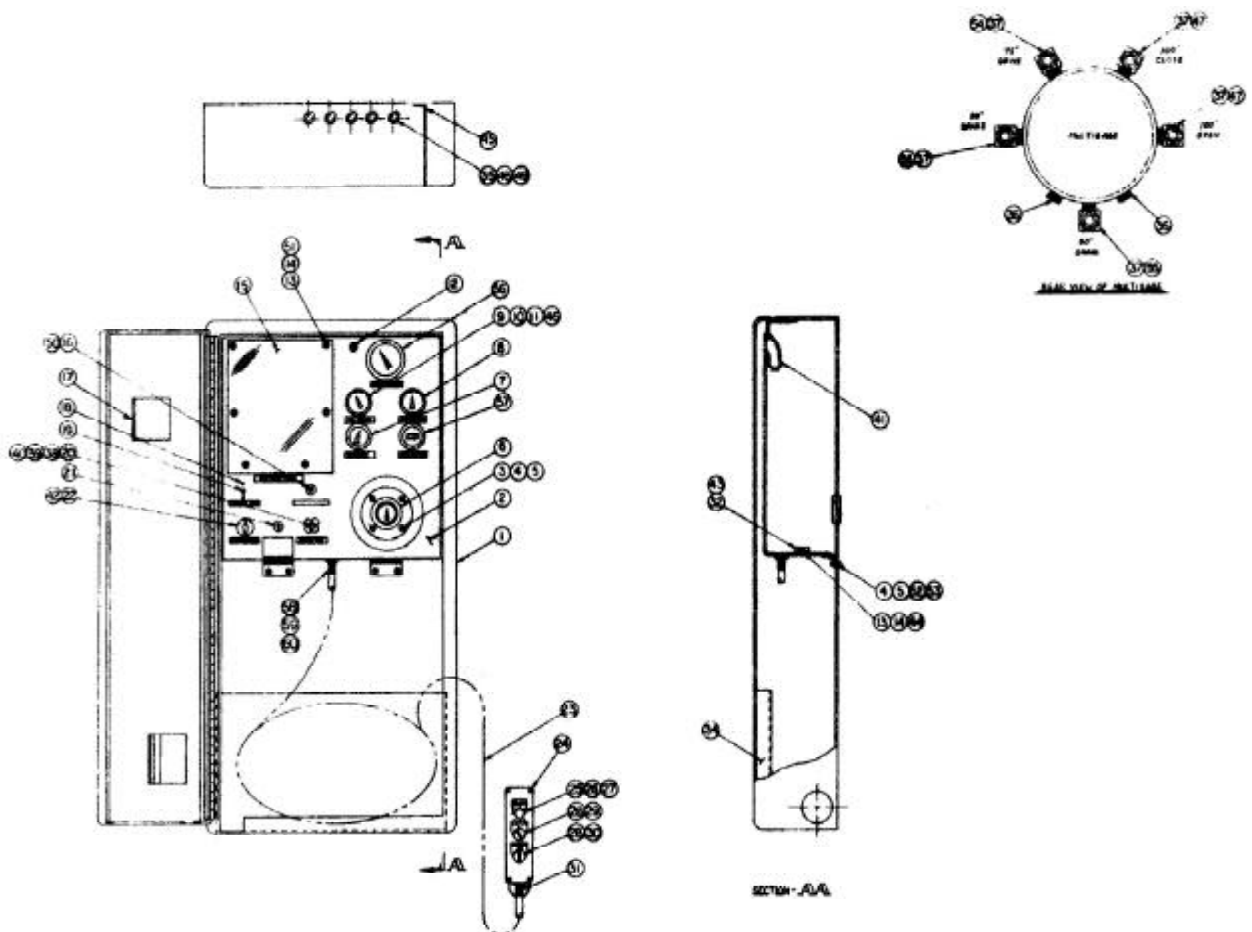



MODEL 416  
VIBRATORY  
DRIVER/EXTRACTOR

# PARTS LIST

CONTROL BOX

810345

Item	Part Number	Qty.	Description
1	130151	1	Enclosure
2	130245	1	Control Panel
3	100557	4	SHCS (1/4 - 20 x 3/4)
4	100559	8	Lockwasher (1/4)
5	100598	8	Hex Nut (1/4 - 20)
6	100925	1	Multi-Gage (GA-1)
7	110371	1	Ammeter
8	130251	1	Water Temperature Gage
9	100329	1	Oil Pressure Gage
10	100333	1	FITT2L-04E02Q000-000H002
11	110415	1	Oil Pressure Hose
12	110321	1	Panel Latch
13	400161	8	Lockwasher (#10)
14	400163	8	Hex Nut (#10 - 32)
15	100311	1	Instruction Frame
16	100355	1	Warning Light
17	100858	1	Label Group
18	100331	2	BHCS (#6 - 32 x 1/4)
19	400141	1	Circuit Breaker
20	130255	1	Engine Throttle
21	130257	1	Reset Button
22	130259	1	Start Switch
23	130365	1	Pendant Cable
24	130153	1	Pendant Enclosure
25	130085	1	Clamp Light
26	100361	1	Clear Lens
27	100403	1	"CLAMP" Nameplate
28	130155	2	Selector Switch
29	100401	1	"OPEN-CLOSE" Nameplate
30	100864	1	"FORW/REVERSE" Nameplate
31	100371	1	Strain Relief
32	110567	12	Terminal Block
34	130149	1	Box Panel





**MODEL 416  
VIBRATORY  
DRIVER/EXTRACTOR**

**PARTS LIST**

CONTROL BOX (CONTINUED)

810345

Item	Part Number	Qty.	Description
35	100853	5	90° Cord Adapter
36	100845	2	FITT2P-04P000000-000S007
37	100145	5	FITT2L-04M04P000-0000001
38	100429	1	Throttle Cable Seal
39	100431	1	Throttle Cable Pivot
40	100577	1	Throttle Cable Clamp
41	110481	1	Chain
42	130273	1	"START" Switch Nameplate
43	110569	1	Terminal Mounting Channel
44	110649	2	PHMS (#10 - 32 x 3/8")
45	130387	1	Hose Bracket
46	100338	1	FITT2L-04P04E000-000H002
47	130207	2	HOSE019R01J004J004L10000
48	110841	5	1/2 Bushing
49	110843	5	1/2 Locknut
50	130377	1	Bulb - 12VDC
51	130061	6	BHCS (#10 - 32 x 1/2")
52	100597	4	Flatwasher (1/4")
53	100576	4	SHCS (1/4 - 20 x 5/8)
54	110409	1	HOSE019R01J004J004L07500
55	130205	2	HOSE019R01J004J004L09000
56	100993	1	Tachometer
	140397	1	Tachometer
	100327	1	Tachometer
57	100343	1	Hourmeter
58	130411	1	Bushing (3/4")
59	100371	1	Strain Relief
60	130409	1	Locknut (3/4")

NOTE 1: Direct replacement - obtain manufacturer from part and indicate when ordering.



MODEL 416  
VIBRATORY  
DRIVER/EXTRACTOR

# PARTS LIST

CONTROL MANIFOLD ASSEMBLY - 250

810353

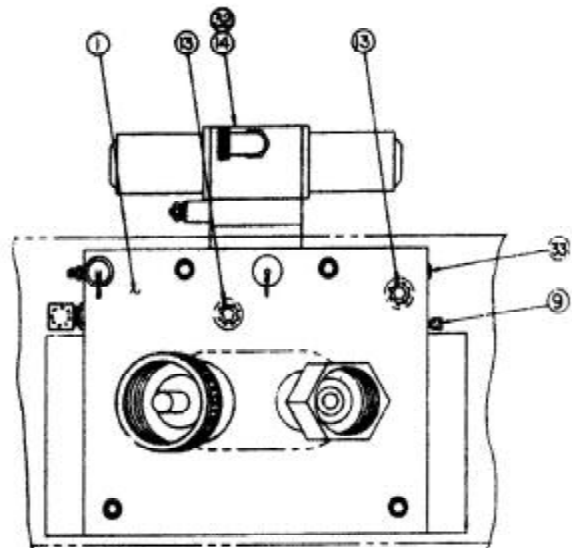
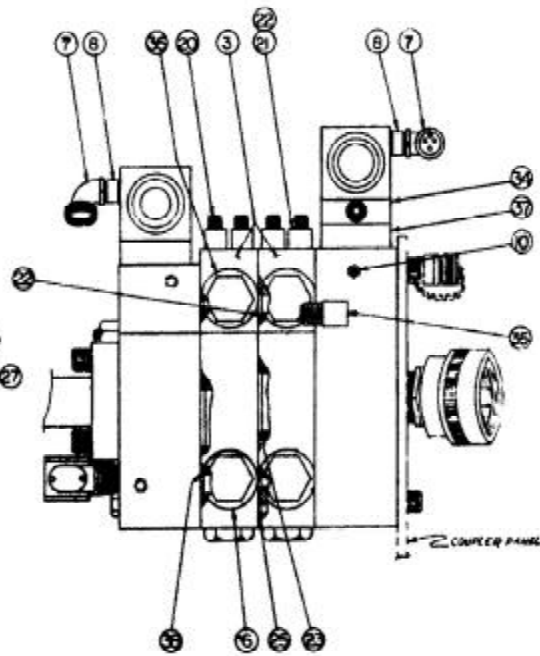
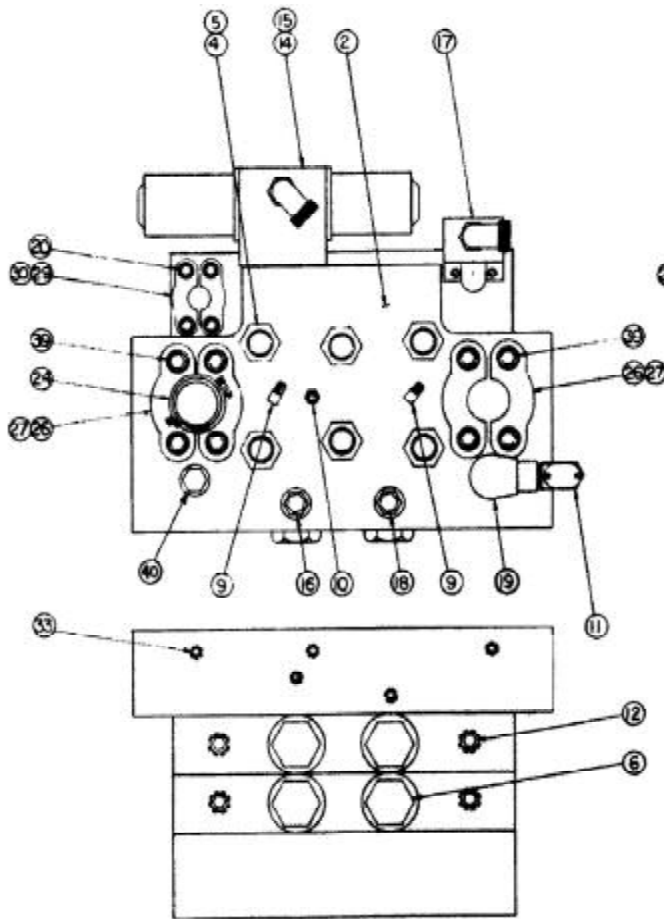



**MODEL 416  
VIBRATORY  
DRIVER/EXTRACTOR**

**PARTS LIST**

CONTROL MANIFOLD ASSEMBLY - 250

810353

Item	Part Number	Qty.	Description
	810377	1	Control Manifold (Includes Items Below:)
1	100996		(1) Port End Plate
2	100998		(1) Control End Plate
3	140247		(2) Valve Block
4	100994		(6) Tie Rod
5	140257		(6) ESNA Nut (7/8-14) UNF
6	140249		(8) Pilot Cartridge (B40)
8	110885		(2) Conduit Adapter
12	100423		(4) FITT2P-08P000000-000S007
13	400213		(2) FITT2P-06P000000-000S007
14	130033		(2) Control Valve (V1) (V2)
15	100631		(4) SHCS (1/4-20 x 2)
16	140133		(1) Relief Valve - 500 (RV4)
18	140131		(1) Relief Valve - 4500 (RV1)
19	100872		(1) Cooler Valve (V3)
23	140253		(12) O-Ring (#330)
25	140255		(18) O-Ring (#113)
32	100900		(4) SHCS (1/4-20 x 6)
33	100646		(9) FITT2P-02P000000-000S007
34	100898		(1) Relief Valve (RV2)
36	140251		(4) Pilot Cartridge (A-100)
37	110149		(1) Check Valve (CV5)
38	110631		(3) O-Ring (#117)
7	110235	2	S/O Cord Adapter - 90°
9	140539	3	FITT2L-04M02P000-0000001
10	140267	2	FITT2S-04M02P000-000H001
11	100868	1	Conduit Adapter - 90°
17	810033	1	Pressure Switch Assembly (PS-1)
20	100143	12	SHCS (3/8 - 16 x 1-1/4)
21	140101	4	Split Flange Half (Special)
22	100091	5	O-Ring (#219)
24	100954	1	Flex Master - 1-1/2
26	100596	4	Split Flange Half (#24)
27	110119	2	O-Ring (#225)
29	100049	2	Split Flange Half (#12)
30	100097	1	O-Ring (#214)
35	110211	1	FITT2L-12R08M000-000H001
39	100119	8	SHCS (1/2 - 13 x 1-1/4)
40	140135	1	Check Valve (CV2)



**MODEL 416  
VIBRATORY  
DRIVER/EXTRACTOR**

# PARTS LIST

**MODEL 125 UNIVERSAL CLAMP**

800039

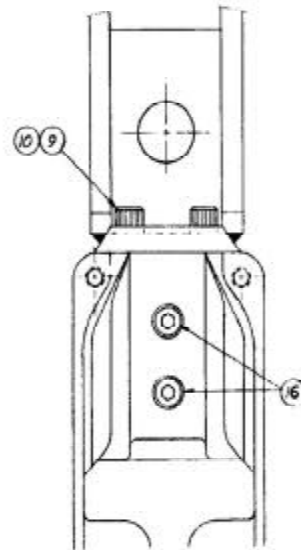
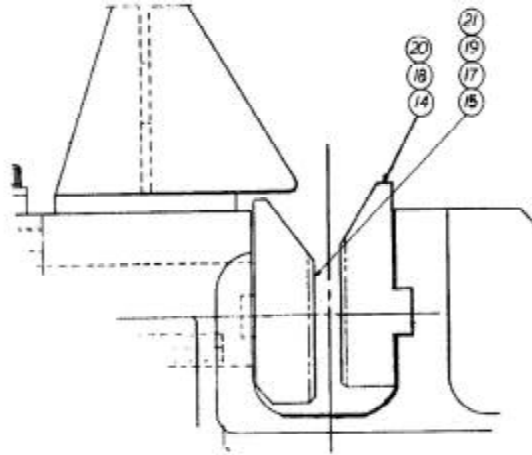

**Figure 2  
S/N up to 250744 incl.**

SECTION A-A

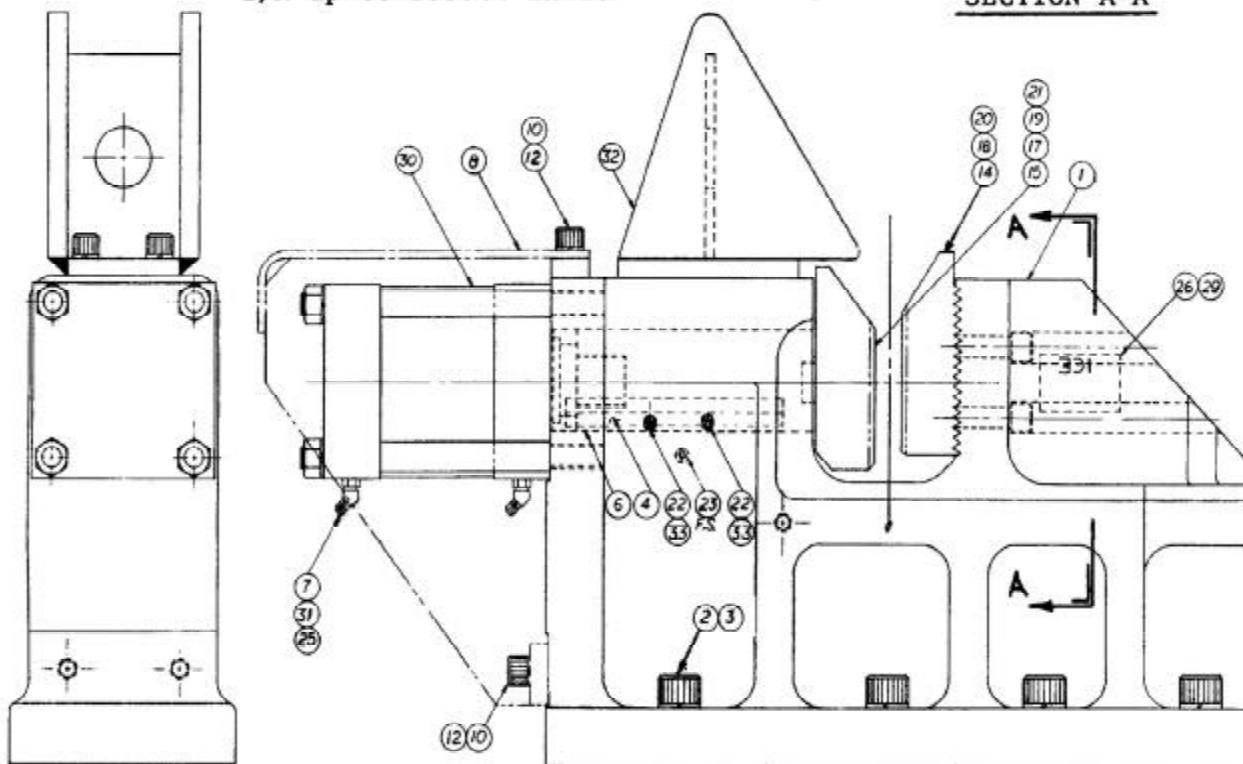

**Figure 1  
S/N 250745 and above**



**MODEL 416  
VIBRATORY  
DRIVER/EXTRACTOR**

**PARTS LIST**

MODEL 125 UNIVERSAL CLAMP

800039

Item	Part Number	Qty.	Description
1	810057	1	Clamp Body
2	100193	8	SHCS (1-1/2-6 x 5)
3	100195	8	Lockwasher (1-1/2 Heavy)
4	100197	1	Key
6	100201	1	Plunger
7	100203	2	FITT2V-06M06R000-000H001
8	100205	1	Cylinder Cover
9	100207	4	SHCS (1 - 8 x 3)
10	100209	8	Lockwasher (1)
12	100213	4	SHCS (1 - 8 x 2-1/2)
14	100215	1	Universal Jaw - Fixed (Keyed Back) <span style="float:right">Note 1</span>
	110515	1	Universal Jaw - Fixed (Saw Tooth Back) <span style="float:right">Note 2</span>
15	100217	1	Universal Jaw - Moveable
16	100212	2	SHCS (1 - 8 x 4)
17	100214	2	Jaw Bolt - Moveable
18	100219	1	Double Sheeting Jaw - Fixed (Keyed Back) <span style="float:right">Note 1</span>
	110419	1	Double Sheeting Jaw - Fixed (Saw Tooth Back) <span style="float:right">Note 2</span>
19	100221	1	Double Sheeting Jaw - Moveable
20	100223	1	H-Beam Jaw - Fixed (Keyed Back) <span style="float:right">Note 1</span>
	100541	1	H-Beam Jaw - Fixed (Saw Tooth Back) <span style="float:right">Note 2</span>
21	100225	1	H-Beam Jaw - Moveable
22	100227	2	SHCS (3/8 - 16 x 2-1/4)
23	100229	1	Grease Fitting (1/8" NPT)
25	100230	2	Hose Plug
26	100791	1	Serial Number Plate
29	130381	4	Rivet
30	810189	1	Cylinder (CYL)
	810121	1	Seal Kit
	810129	1	Seal Kit
	810211	1	Seal Kit <span style="float:right">Note 3</span>
31	100228	2	HOSE038R02J006J006L0610S
32	100983	1	Pile Feed Guide
33	400149	2	Lockwasher (3/8)

Note 1: Required on universal clamps with serial numbers up to and including 250744 (Figure 2).

Note 2: Required on universal clamps with serial number above 250745 only. (Figure 1).

Note 3: To determine correct kit number - check Universal Clamp S/N and then consult SEAL KIT REORDER CHART. page VIII-47.



**MODEL 416  
VIBRATORY  
DRIVER/EXTRACTOR**

# PARTS LIST

POWER UNIT - SILENCER GROUP - 250

800251

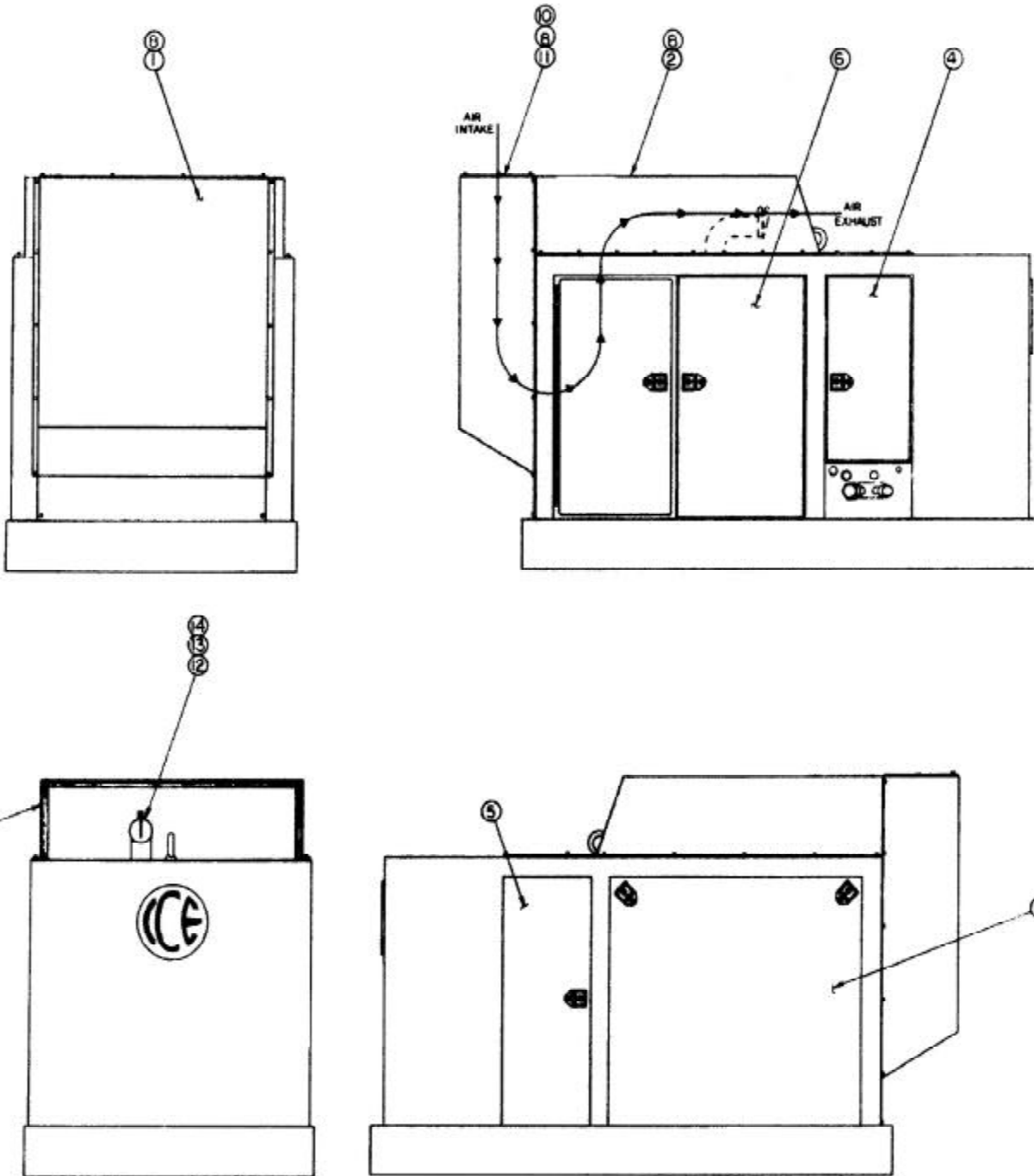



**MODEL 416  
VIBRATORY  
DRIVER/EXTRACTOR**

# PARTS LIST

POWER UNIT - SILENCER GROUP (OPTIONAL)

800251

<u>Item</u>	<u>Part Number</u>	<u>Qty.</u>	<u>Description</u>
1	130159	1	Intake Silencer
2	130161	1	Exhaust Silencer
3	100901	1	Cover Door
4	100896	1	Cover Door
5	100867	1	Cover Door
6	100869	1	Cover Door
7	100859	1	Acoustical Padding
8	130209	32	Hex Teks (1/4-14 x 5/8)
10	130227	10	Fender Washer (1/4)
11	810335	1	Intake Silencer Grill
12	100902	1	Exhaust Clamp
13	100960	1	Exhaust Elbow
14	100890	1	Rain Cap



**MODEL 416  
VIBRATORY  
DRIVER/EXTRACTOR**

# PARTS LIST

MODEL 127 Z-PILE CLAMP (OPTIONAL)

800041

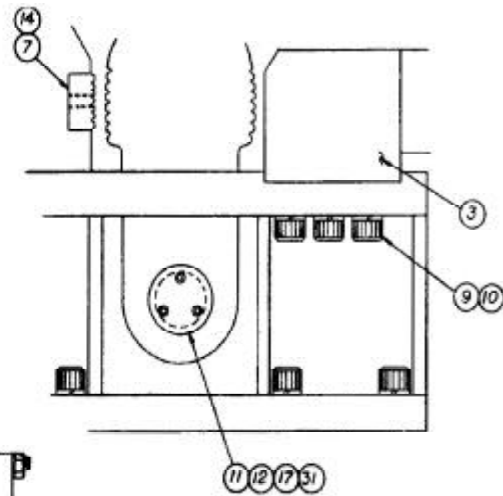

**Figure 2**

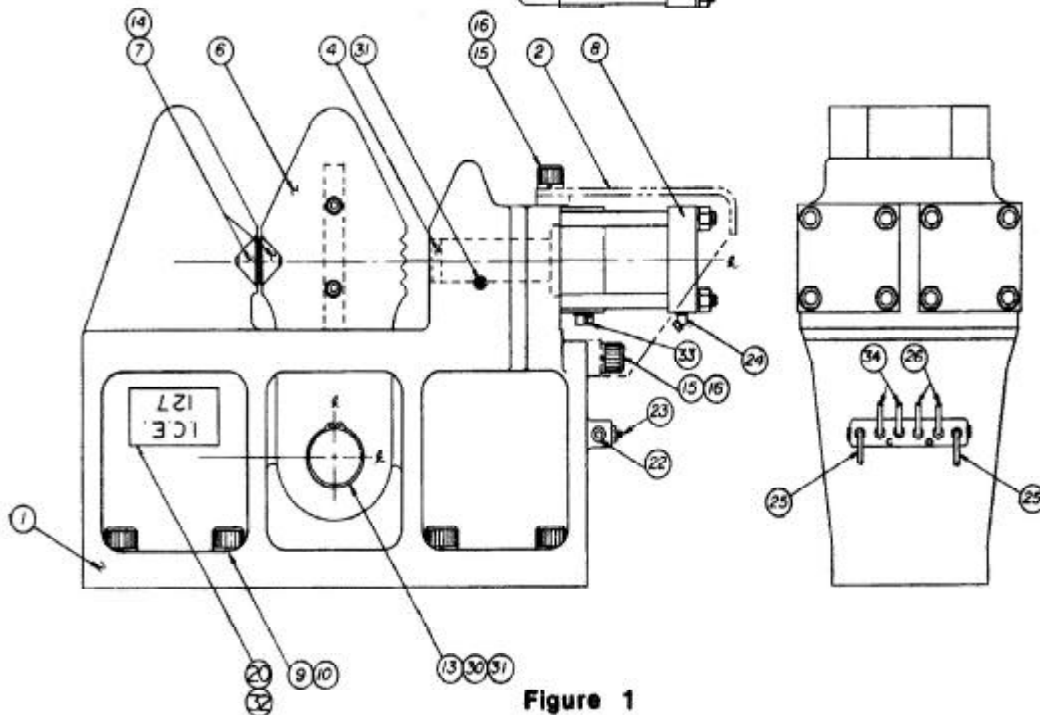
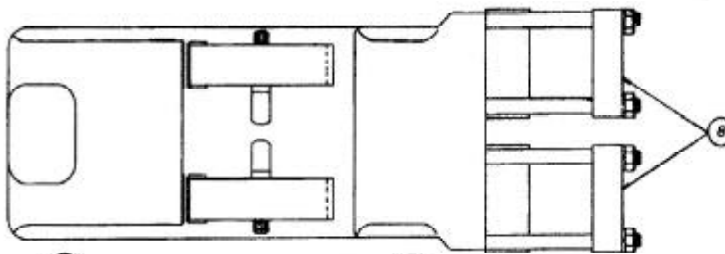

**Figure 1**





**MODEL 416  
VIBRATORY  
DRIVER/EXTRACTOR**

**PARTS LIST**

MODEL 127 Z-PILE CLAMP (OPTIONAL)

800041

Item	Part Number	Qty.	Description
1	810059	1	Clamp Body
2	120137	1	Cylinder Guard
3	120139	2	Guide Block Note 2
4	810193	2	Cylinder Rod Assembly } Note 4
	810195	2	Cylinder Rod Assembly }
	810197	2	Cylinder Rod Assembly }
6	800123	1	PZ-27 Swivel Insert Jaw
	800139	1	Multi-Grip Inserts
7	120187	2	Jaw Insert Note 3
	120149	2	Jaw Insert Note 2
8	810175	2	Cylinder (CYL)
	810123	2	Seal Kit } Note 1
	810131	2	Seal Kit }
	810003	2	Seal Kit }
	810029	2	Seal Kit }
9	100193	8	SHCS (1 - 1/2 - 6 x 5)
10	100195	8	Lockwasher (1-1/2)
11	120153	2	Retainer Plate Note 2
12	120121	6	Lockwasher (1/2) Note 2
13	120155	1	Shaft
14	100163	2	SHCS (1/2-13 x 1-3/4) Note 3
	300043	2	SHCS (1 - 8 x 8) Note 2
15	100213	4	SHCS (1-8 x 2-1/2)
16	100209	4	Lockwasher (1")
17	100513	6	SHCS (1/2-13 x 1-1/2) Note 2
20	120181	1	Serial Number Name Plate
22	400213	2	FITT2P-06P000000-000S007
23	400203	6	FITT2S-06M06P000-000H001
24	100203	2	FITT2V-06M06R000-000H001
25	100111	2	HOSE038R02J006J006L0875S
26	120177	2	HOSE025R02J006J006L01400
30	120191	2	Retaining Ring
31	100229	4	Grease Fitting
32	130381	4	Rivet
33	130057	2	FITT2L-06M06R000-000H001
34	120179	2	HOSE025R02J006J006L02000

Note 1: To determine correct seal kit P/N, check Z-Clamp serial number on unit and then consult SEAL KIT REORDER CHART, page VIII-47 for model 127 cylinder.

Note 2: Required on clamp heads as shown in Figure 2.

Note 3: Required on clamp heads as shown in Figure 1.

Note 4: To determine correct cylinder rod assembly P/N, check Z-Clamp serial number on unit and then consult SEAL KIT REORDER CHART, page VIII-47 for model 127 cylinder. Read column on right of chart for "CYLINDER ROD ASSEMBLY".



**MODEL 416  
VIBRATORY  
DRIVER/EXTRACTOR**

# PARTS LIST

MODEL 80 CAISSON CLAMP (OPTIONAL)

800047

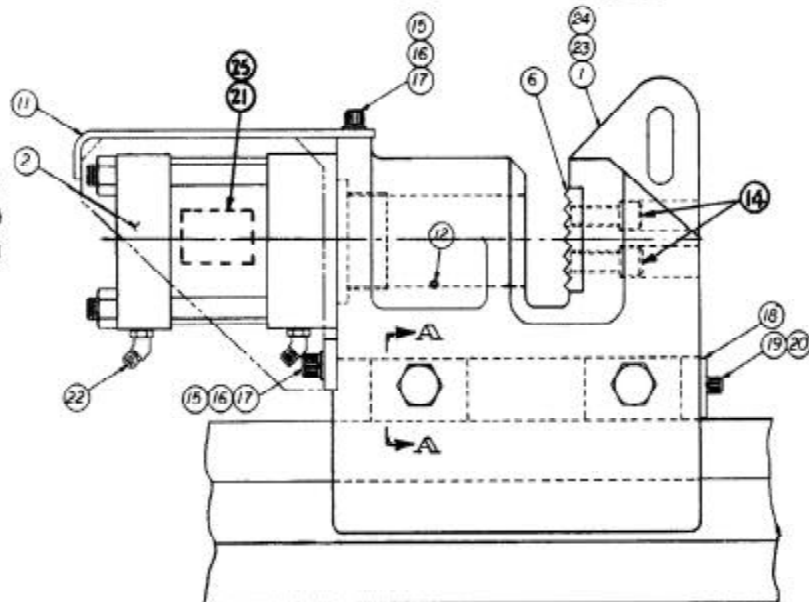
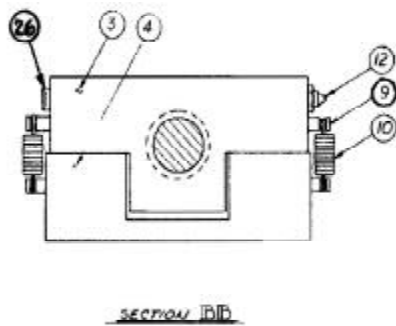
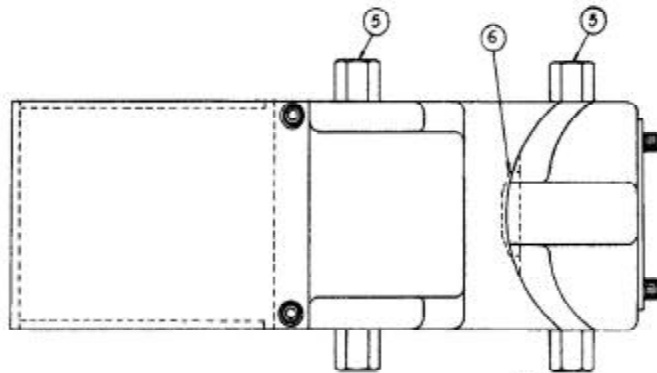
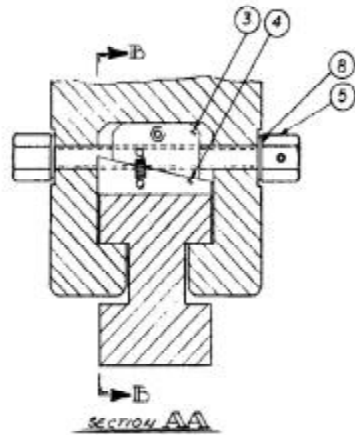

**Fig. 1  
Integral Jaw**

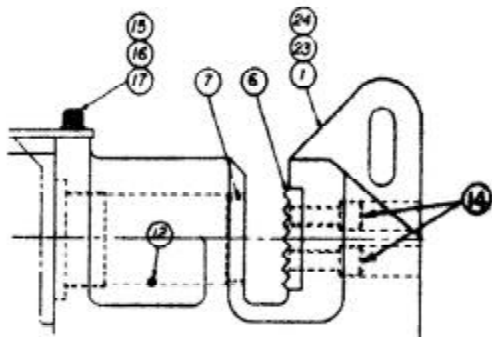

**Fig. 2  
Threaded Jaw**



**MODEL 416  
VIBRATORY  
DRIVER/EXTRACTOR**

# PARTS LIST

MODEL 80 CAISSON CLAMP (OPTIONAL)

800047

Item	Number	Qty.	Description
1	810061	1	Clamp Body
2	810221	1	Cylinder
	810125	1	Seal Kit
	810133	1	Seal Kit
	810227	1	Seal Kit
3	120101	2	Wedge
4	120103	2	Lock
5	810109	2	Screw Assembly
6	120107	1	Fixed Jaw
7	120109	1	Moveable Jaw (See Note 2)
8	120111	4	Washer
9	120113	8	Drive Pin
10	120115	4	Spring
11	120117	1	Cylinder Guard
12	100229	3	Grease Fitting
14	400157	2	SHCS (5/8 - 11 x 2-3/4)
15	400069	4	SHCS (3/4 - 10 x 2)
16	100069	4	Lockwasher (3/4)
17	100589	2	Flatwasher (3/4)
18	120119	1	Wedge Guard
19	100119	2	SHCS (1/2 - 13 x 1-1/4)
20	100121	2	Lockwasher (1/2)
21	120159	1	Clamp Label
22	130057	2	FITT2L-06M06R000-000H001
25	130381	4	Rivet
26	100646	2	FITT2P-02P000000-000S007

Note 1: To determine correct seal kit part number, check caisson clamp serial number on unit and then consult SEAL KIT REORDER CHART, page VIII-47 for model 80 cylinder.

Note 2: Item available only on models with threaded jaws, otherwise, this jaw is integral with the cylinder rod and item 7 is not applicable (Figures 1 and 2).



**MODEL 416  
VIBRATORY  
DRIVER/EXTRACTOR**

# PARTS LIST

CAISSON BEAM (7 FOOT) - OPTIONAL

800045

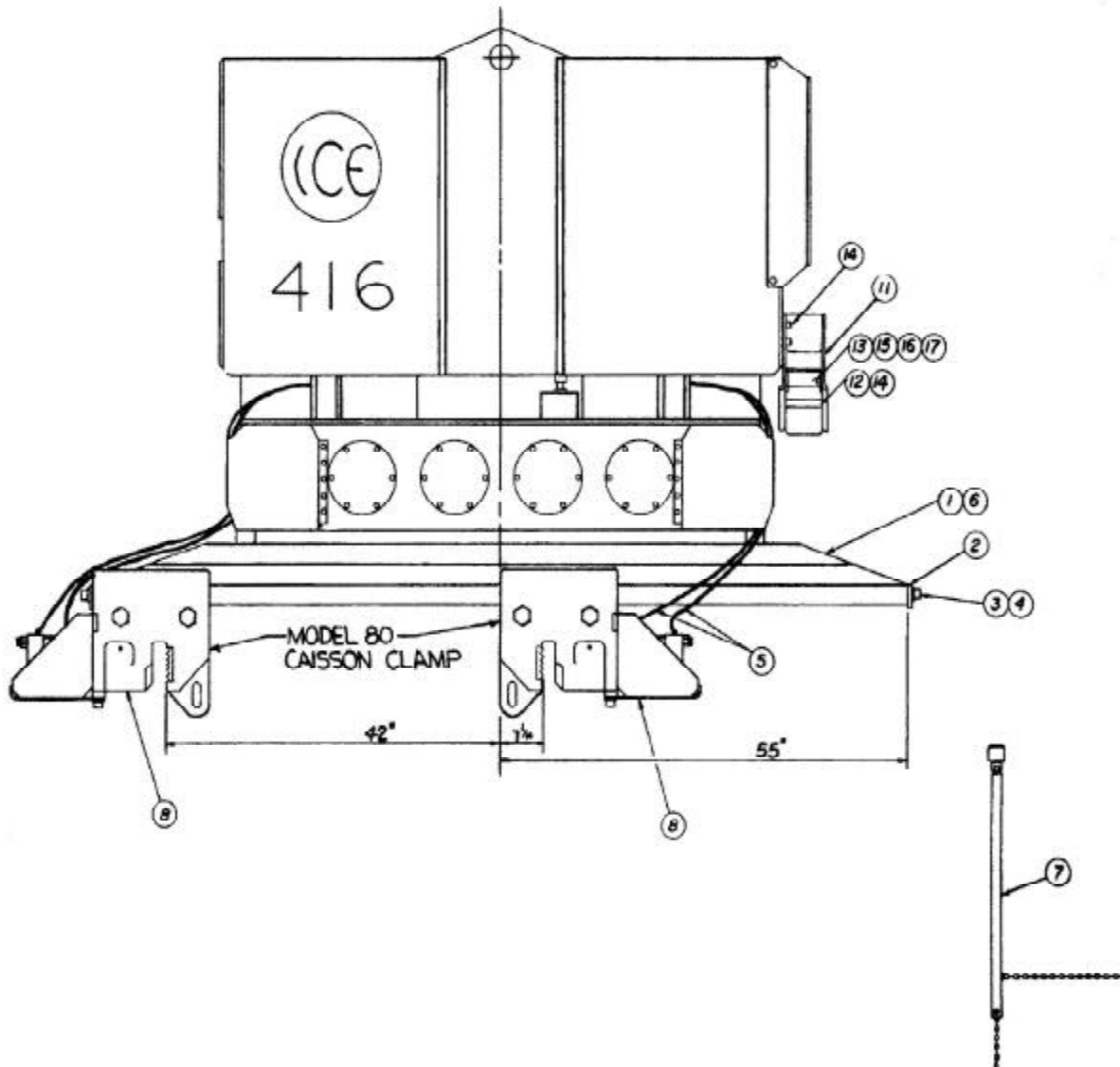



MODEL 416  
VIBRATORY  
DRIVER/EXTRACTOR

# PARTS LIST

CAISSON BEAM - (7 FOOT) OPTIONAL

800045

Item	Part Number	Qty.	Description
1	120001	1	7' Caisson Beam
2	120011	2	Clamp Stop
3	400069	4	SHCS (3/4 - 10 x 2)
4	100069	4	Lockwasher (3/4)
5	120009	4	HOSE038R02J006J006L0960S
6	120007	15	SHCS (1 - 1/2 - 6 x 8)
7	810173	1	Adjustment Tool
8	800047	2	Caisson Clamp - Model 80
11	110517	1	Caisson Hose Guide
12	110519	1	Hose Guide Rod
13	110521	1	Hose Guide Bracket
14	100575	6	SHCS (5/8 - 11 x 1-1/4)
15	100513	4	SHCS (1/2 - 13 x 1-1/2)
16	100485	4	Hex Nut (1/2 - 13)
17	100121	4	Lockwasher (1/2)



MODEL 416  
VIBRATORY  
DRIVER/EXTRACTOR

# PARTS LIST

CLAMP EXTENSION - 8 FOOT (OPTIONAL)

800063

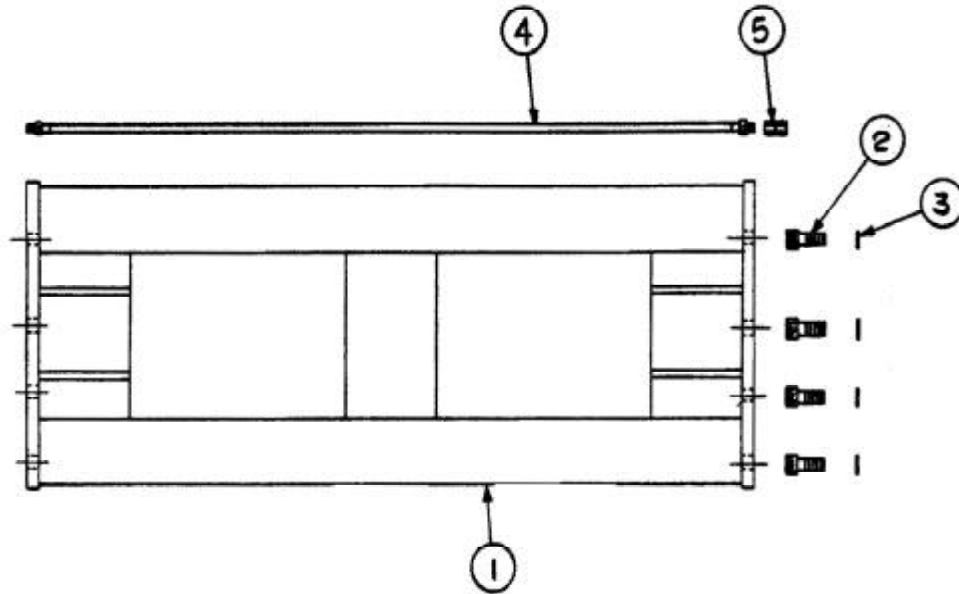

90° CLAMP ADAPTER (OPTIONAL)

800049

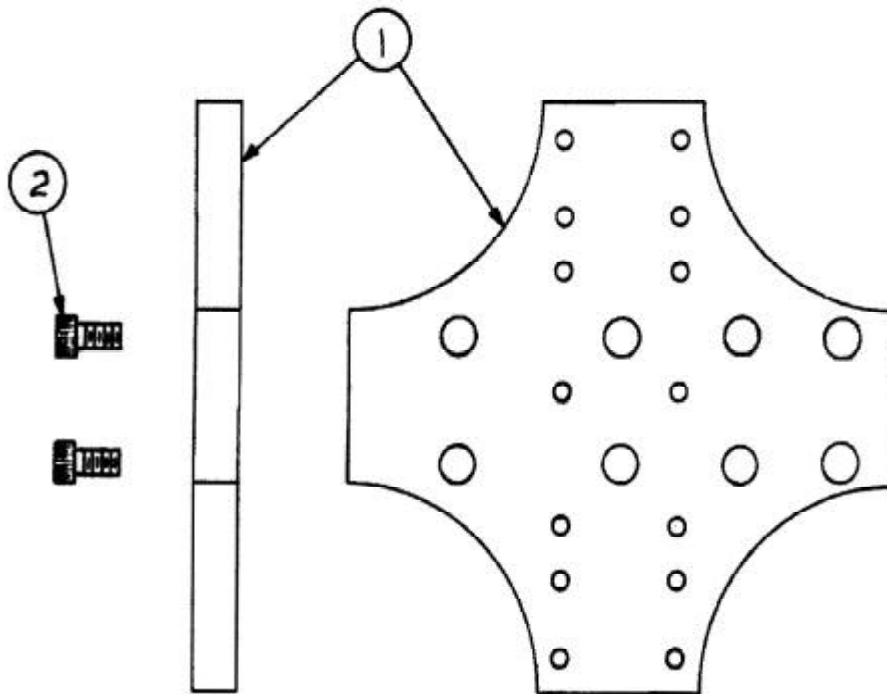



MODEL 416  
VIBRATORY  
DRIVER/EXTRACTOR

# PARTS LIST

CLAMP EXTENSION - (8 FOOT) OPTIONAL

800063

<u>Item</u>	<u>Part Number</u>	<u>Qty.</u>	<u>Description</u>
1	810237	1	8' Extension
2	100193	10	SHCS (1-1/2 - 6 x 5)
3	100195	10	Lockwasher (1-1/2)
4	120009	2	HOSE038R02J006J006L0960S
5	120081	2	FITT2S-06M06M000-000H001

90° CLAMP ADAPTER (OPTIONAL)

800049

<u>Item</u>	<u>Part Number</u>	<u>Qty.</u>	<u>Description</u>
1	120083	1	90° Clamp Adapter
2	120157	8	SHCS (1-1/2 - 6 x 3)



**MODEL 416  
VIBRATORY  
DRIVER/EXTRACTOR**

# PARTS LIST

## VIII. ORDERING PARTS

### E. MISCELLANEOUS ACCESSORIES

#### 1. TOOLS

Part Number	Qty.	Description
100651	1	24-Volt Test Light
100653	1	Set of Allen Wrenches - Includes All Wrenches Shown Below:
100655		(1) 1/16" Allen Wrench - Long Arm
100691		(1) 5/64" Allen Wrench - Long Arm
100569		(1) 3/32" Allen Wrench - Long Arm
100661		(1) 7/64" Allen Wrench - Long Arm
100663		(1) 1/ 8" Allen Wrench - Long Arm
100665		(1) 9/64" Allen Wrench - Long Arm
100667		(1) 5/32" Allen Wrench - Long Arm
100669		(1) 3/16" Allen Wrench - Long Arm
100671		(1) 7/32" Allen Wrench - Long Arm
100673		(1) 1/ 4" Allen Wrench - Long Arm
100657		(1) 5/16" Allen Wrench - Long Arm
100675		(1) 3/ 8" Allen Wrench - Long Arm
100677		(1) 7/16" Allen Wrench - Long Arm
100679		(1) 1/ 2" Allen Wrench - Long Arm
100681		(1) 9/16" Allen Wrench - Long Arm
100683		(1) 5/ 8" Allen Wrench - Long Arm
100685		(1) 3/ 4" Allen Wrench - Long Arm
100687		(1) 7/ 8" Allen Wrench - Short Arm
100689		(1) 1" Allen Wrench - Short Arm

#### 2. BULK

Part Number	Qty.	Description
810013	5 GAL	Hydraulic Fluid
810011	5 GAL	Vibration Case Lubricant
100726	1 GAL	Coolant/Anti-Freeze
100298	1 GAL	I C E Green Paint
100299	1 GAL	Primer





**MODEL 416  
VIBRATORY  
DRIVER/EXTRACTOR**

# PARTS LIST

## VIII. ORDERING PARTS

### E. MISCELLANEOUS ACCESSORIES (CONTINUED)

#### 3. 416 HOSE GROUP KIT - INTERNAL 850033

<u>Item</u>	<u>P/N</u>	<u>Qty.</u>	<u>Description</u>	<u>Page Reference</u>
5	100969	2	HOSE125R10F020F024L0875S	VIII- 14
9	100843	1	HOSE100R01J016F016L0545S	VIII- 14
10	100841	1	HOSE100R01J016F016L0370S	VIII- 14
13	100099	1	HOSE075R02F012F012L0880S	VIII- 14
14	100839	1	HOSE075R10J012F012L0580S	VIII- 14
15	100837	1	HOSE075R10J012F012L0400S	VIII- 14
19	100835	1	HOSE050R01J008F008L0525S	VIII- 14
20	100833	1	HOSE050R01J008F008L0350S	VIII- 14
22	100111	2	HOSE038R02J006J006L0875S	VIII- 14
23	110633	2	HOSE038R02J006J006L0370S	VIII- 14
24	100108	2	HOSE038R02J006J006L0200S	VIII- 14
31	100228	2	HOSE038R02J006J006L0610S	VIII- 33

#### 4. 250 HOSE GROUP KIT - INTERNAL 850061

<u>Item</u>	<u>P/N</u>	<u>Qty.</u>	<u>Description</u>	<u>Page Reference</u>
78	400217	1	HOSE075R01P012J012L01800	VIII- 21
79	400215	1	HOSE100R01P016P016L08400	VIII- 18
98	100947	1	HOSE150R01P024F924L07700	VIII- 21
99	100932	1	HOSE100R01J016J016L05500	VIII- 18
100	300115	1	HOSE075R01J012J012L02600	VIII- 18
101	100928	1	HOSE050R09J008J008L02200	VIII- 18
102	100926	1	HOSE150R02P024F924L09300	VIII- 18
103	100924	1	HOSE100PT4F016F016L06000	VIII- 18
104	100922	1	HOSE100PT4F016F016L04000	VIII- 18
186	100941	1	HOSE075R01J012J012L04400	VIII- 21
187	100149	2	HOSE025R02J004J004L01900	VIII- 18
47	130207	2	HOSE019R01J004J004L10000	VIII- 26
54	110409	1	HOSE019R01J004J004L07500	VIII- 26
55	130205	2	HOSE019R01J004J004L09000	VIII- 26



**MODEL 416  
VIBRATORY  
DRIVER/EXTRACTOR**

# PARTS LIST

## VIII. ORDERING PARTS

### E. MISCELLANEOUS ACCESSORIES (CONTINUED)

5. 416/250 O-RING KIT 850063

<u>P/N</u>	<u>Qty.</u>	<u>Description</u>
110217	2	Back-Up Ring (#239)
110215	5	O-Ring (#239)
110197	6	O-Ring (#159)
100781	6	O-Ring (#156)
100167	16	O-Ring (#266)
100037	10	O-Ring (#222)
100091	15	O-Ring (#219)
100097	10	O-Ring (#214)
100107	10	O-Ring (#210)
110119	16	O-Ring (#225)
140253	24	O-Ring (#330)
140255	36	O-Ring (#113)
110631	6	O-Ring (#117)

6. QUICK DISCONNECT REBUILD KIT 850067

<u>Qty.</u>	<u>Description</u>
1	Male Check Poppet Valve
1	Female Check Poppet Valve
2	Snap-Lock Ring
1	Snap-Ring Pliers



**MODEL 416  
VIBRATORY  
DRIVER/EXTRACTOR**

**PARTS LIST**

VIII. ORDERING PARTS

E. MISCELLANEOUS ACCESSORIES (CONTINUED)

6. CYLINDER SEAL KIT REORDER CHARTS

MODEL 125 UNIVERSAL CLAMP CYLINDER

PG. VIII-32

Cylinder Seal Kit		Item 30
Unit S/N	Kit P/N	Make of cyl.
241201 thru 250607 250708 thru 250749	810121	S. P.
250750 thru 250794	810129	SHEFFER
250795 and above	810211	J M

MODEL 127 Z-PILE CLAMP CYLINDER

PG. VIII-36

Cylinder Seal Kit		Item 8 & Rod Ass'y - Item 4	
Unit S/N	Kit P/N	ITEM 8 Make of cyl.	ITEM 4 Rod Ass'y
254701 thru 254707 and 254709	810123	S. P.	810193
254708 and 254712 thru 254714 254716 thru 254717 254722 thru 254725	810131	SHEFFER	810195
254710 and 254711	810003	J M-1	810197
254715 and 254718 thru 254721	810029	J M-2	

MODEL 80 CAISSON CLAMP CYLINDER

PG. VIII-38

Cylinder Seal Kit		Item 2
Unit S/N	Kit P/N	Make of cyl.
252701 thru 252720 252731 thru 252736	810125	S. P.
252721 thru 252730	810133	SHEFFER
252737 and above	810227	J M



**MODEL 416  
VIBRATORY  
DRIVER/EXTRACTOR**

**PARTS LIST**

VIII. ORDERING PARTS

F. RECOMMENDED SPARE PARTS

VIBRATION SUPPRESSOR 800027 Refer to page VIII- 6

Item	P/N	Qty.	Description
2	100003	1	Elastomer
20	100035	1	Filter Element
21	100037	2	O-Ring (#223)
57	110215	1	O-Ring (#239)
58	110217	1	Back-Up Ring (#239)
79	100097	2	O-Ring (#214)

VIBRATION CASE 810037 Refer to page VIII-10

Item	P/N	Qty.	Description
14	110197	2	Motor O-Ring (#159)
15	100781	2	Bearing O-Ring (#156)
21	100167	8	O-Ring (#266)
--	110607	2	Motor Shaft Seal
30	100185	1	Sight Gauge

HOSE ASSEMBLIES-INTERCONNECTING 800029 Refer to page VIII-12

Item	P/N	Qty.	Description
5	100233	1	HOSE125R10P020P020L60000
9	100911	1	HOSE150R02P024P024L60000
13	100241	1	HOSE075R02P012P012L62000
17	100247	2	HOSE038R02P006P006L62000

DISTRIBUTION BLOCK 810041 Refer to page VIII-14

Item	P/N	Qty.	Description
4	100037	2	O-Ring (#222)
8	100091	2	O-Ring (#219)
12	100097	4	O-Ring (#214)
18	100107	2	O-Ring (#210)
25	110119	2	O-Ring (#225)



**MODEL 416  
VIBRATORY  
DRIVER/EXTRACTOR**

**PARTS LIST**

VIII. ORDERING PARTS

F. RECOMMENDED SPARE PARTS (CONTINUED)

POWER UNIT - INTERNAL (250) 800239 Refer to page VIII-18/21

Item	P/N	Qty.	Description
14	810117	1	Filter Element
21	100912	1	Air Cleaner Element
100	300115	1	HOSE075R01J012J012L02600
101	100928	1	HOSE050R09J008J008L02200
103	100924	1	HOSE100PT4F016F016L06000
104	100922	1	HOSE100PT4F016F016L04100
154	110119	4	O-Ring (#225)
156	100091	2	O-Ring (#219)

CONTROL MANIFOLD ASSEMBLY (250) 810353 Refer to page VIII-30

Item	P/N	Qty.	Description
22	100091	2	O-Ring (#219)
23	140253	6	O-Ring (#330)
25	140255	9	O-Ring (#113)
27	110119	4	O-Ring (#225)
30	100097	2	O-Ring (#214)
38	110631	2	O-Ring (#117)

MODEL 125 UNIVERSAL CLAMP 800039 Refer to page VIII-32

Item	P/N	Qty.	Description
2	100193	8	SHCS (Head Bolts) 1-1/2 - 6 x 5
3	100195	8	Lockwasher, Heavy (1-1/2)
7	100203	2	FITT2V-06M06R000-000H001
14	--	1	Universal Jaw - Fixed
18	--	1	Double Sheeting Jaw - Fixed
20	--	1	H-Beam Jaw - Fixed
15	--	1	Universal Jaw - Moveable
19	--	1	Double Sheeting Jaw-Moveable
21	--	1	H-Beam Jaw - Moveable
16	100212	2	SHCS (Jaw Bolts - Fixed) 1 - 8 x 4
17	100214	2	Jaw Bolt - Moveable
30	--	1	Seal Kit for Cylinder Note 3
31	100228	2	HOSE038R02J006J006L0610S

Note 1: To determine whether keyed back or saw-tooth back is required, see Note 1 and Note 2 on page VIII-33. Then order appropriate type jaw, either Universal, Double Sheeting or H-Beam.

Note 2: Order appropriate type jaw-either Universal, Double Sheeting or H-Beam.

Note 3: To determine correct seal kit, see Note 3 on page VIII-33.



**MODEL 416  
VIBRATORY  
DRIVER/EXTRACTOR**

**PARTS LIST**

VIII. ORDERING PARTS

F. RECOMMENDED SPARE PARTS (CONTINUED)

MODEL 127 Z-PILE CLAMP                      800041                      Refer to page VIII-36

Item	P/N	Qty.	Description
9	100193	8	SHCS (Head Bolts) 1-1/2-6 x 5
10	100195	8	Lockwasher, Heavy (1-1/2)
23	400203	2	FITT2S-06M06P000-000H001
24	100203	2	FITT2V-06M06R000-000H001
25	100111	1	HOSE038R02J006J006L0875S
26	120177	1	HOSE025R02J006J006L01400
33	130057	2	FITT2L-06M06R000-000H001
34	120179	1	HOSE025R02J006J006L02000
7	120187	2	Jaw Insert    Note 1
	120149	2	Jaw Insert    Note 1
8	810123	1	Clamp Cylinder Seal Kit    Note 2
	810131	1	Clamp Cylinder Seal Kit    Note 2
	810003	1	Clamp Cylinder Seal Kit    Note 2
	810029	1	Clamp Cylinder Seal Kit    Note 2

MODEL 80 CAISSON CLAMP                      800047                      Refer to page VIII-38

Item	P/N	Qty.	Description
5	810109	1	Screw Assembly
6	120107	1	Fixed Jaw
7	120109	1	Moveable Jaw    Note 3
14	400157	2	SHCS (5/8 - 11 x 2-3/4)
22	130057	2	FITT2L-06M06R000-000H001
2	810125	1	Clamp Cylinder Seal Kit    Note 4
	810133	1	Clamp Cylinder Seal Kit    Note 4
	810227	1	Clamp Cylinder Seal Kit    Note 4

Note 1: Determine configuration of jaw by referring to page VIII-36. Order P/N 120187 for jaw in Fig. 1. Order P/N 120149 for jaw as shown in Fig. 2.

Note 2: To determine correct seal kit, see Note 1 on page VIII-37.

Note 3: Item available only on models with threaded jaws. Otherwise, this jaw is integral with the cylinder rod and not applicable.

Note 4: To determine correct seal kit, see Note 1 on page VIII-39.