

# OPERATION AND MAINTENANCE MANUAL

Covers Model 400 vibro and 1000 power unit, including applicatons when used as a single unit.

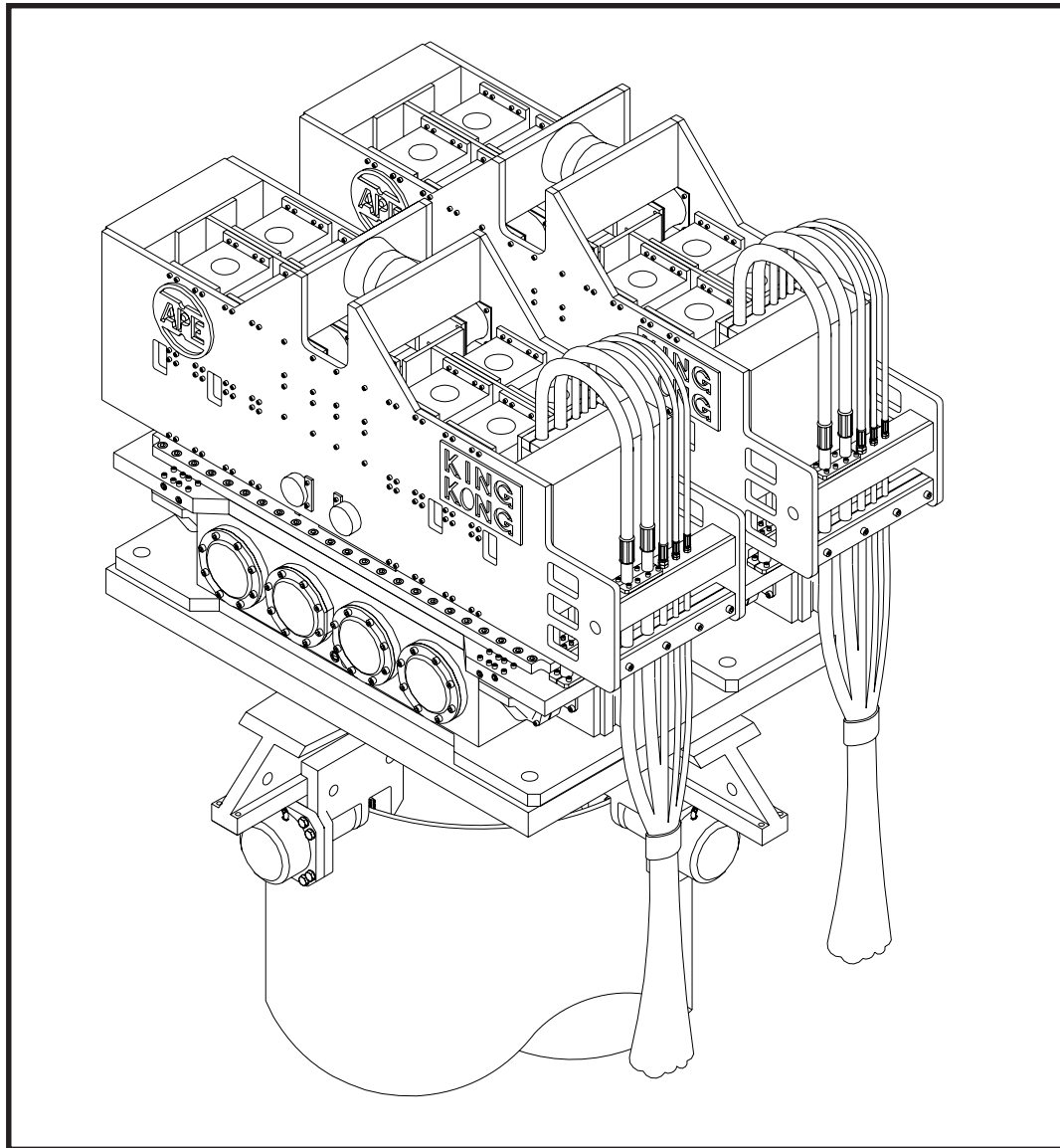

## MODEL 400 VIBRO TANDEM WITH MODEL 1000 POWER UNIT



# **OPERATION // MAINTENANCE MANUAL**

**MODEL 100 BIT AND RABBIT HAMMER WITH  
MODEL 1000 POWER UNITS**

700325 So. 196th - Kent, WA 98032 - (206) 897 2014 / Fax (206) 897 2871

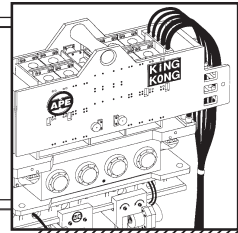

## Revision Record

Change Number	Page Number	Date	Revision Description
		10/12/04	



# **OPERATION / MAINTENANCE MANUAL**

## **MODEL 400 TANDEM VIBRATORY HAMMER WITH MODEL 1000 POWER UNITS**

7032 So. 196th - Kent, WA. 98032 - (206) 872-0141 / Fax (206) 872-8710

### **Preface**

#### **General**

This manual covers the **Model 400 Vibratory Hammer and Model 1000 Power Unit**. It has been modified to cover the use of two Model 400's mounted together for installation of large caissons. The data provided in this manual gives the necessary information to operate and maintain APE equipment. The listed procedures are to be performed by qualified personnel who have an understanding of the equipment and who follow all safety precautions.

#### **Guide to Using the Manual**

1. Refer to the Table of Contents for the page location of applicable sections.
2. All weights and measurements in this manual are in both English and Metric units.
3. The manual will be revised as necessary to reflect current information.

#### **Abbreviations**

The following are abbreviations used within this manual.

<b>lbs.</b>	= Pounds	<b>CV</b>	= Check Valve
<b>psi.</b>	= Pounds per Square Inch	<b>QD</b>	= Quick Disconnect Coupler
<b>hp.</b>	= Horse Power	<b>P/N</b>	= Part Number
<b>gpm.</b>	= Gallons Per Minute	<b>Mfg.</b>	= Manufacturer
<b>rpm.</b>	= Revolutions Per Minute	<b>Qty</b>	= Quantity
<b>eng.</b>	= Engine	<b>FWD</b>	= Forward
<b>cyl.</b>	= Cylinder	<b>REV</b>	= Reverse
<b>mm.</b>	= Millimeter		
<b>mtg.</b>	= Mounting		
<b>S/N</b>	= Serial Number		
<b>sol.</b>	= Solinoid		

#### **Serial Number Locations**

1. **VIBRATOR:** Above and in between the eccentric covers on both sides of the machine.
2. **POWER UNIT:** On back of the hydraulic tank above the APE logo.



# OPERATION / MAINTENANCE MANUAL

## MODEL 400 TANDEM VIBRATORY HAMMER WITH MODEL 1000 POWER UNITS

7032 So. 196th - Kent, WA. 98032 - (253) 872-0141 / Fax (253) 872-8710

### Table of Contents

	Page
Revision Record .....	i
Preface .....	ii
Table of Contents .....	iii
Safety Precautions .....	v
Illustration List .....	vi
Table List .....	vi
Warranty .....	vii
<b>I. GENERAL INFORMATION .....</b>	<b>1-1</b>
I-1. Machine Features .....	1-1
I-2. Machine Specifications .....	1-2
A. Model 400 Vibro .....	1-2
B. Model 1000 Power Unit .....	1-2
I-3. General Description of Model 400 Vibro .....	1-3
A. Suppressor Housing .....	1-4
B. The Vibrator Gearbox .....	1-5
C. Clamp Attachment .....	1-6
D. Optional Attachments .....	1-7
I-4. General Description of Model 1000 Power Unit .....	1-8
<b>II. MAJOR COMPONENT DEFINITION .....</b>	<b>2-1</b>
II-1. Component Identification .....	2-1
II-2. Tandem Plate w/ Caisson Beams .....	2-3
II-3. Caisson Clamp Identification .....	2-4
II-4. Hose Bundle Identification .....	2-5
II-5. Model 1000 Power Unit Skid Identification .....	2-7
II-6. Quick Disconnect Couplings .....	2-8
II-7. Tool Set Identification .....	2-9
<b>III. LOADING AND UNLOADING .....</b>	<b>3-1</b>
III-1. Model 400 Vibratory Hammer .....	3-1
III-2. Model 1000 Power Unit .....	3-1
III-3. What to do if damaged during shipment .....	3-1
<b>IV. PREPARATION AND OPERATION .....</b>	<b>4-1</b>
IV-1. Rigging of Vibratory Hammer .....	4-1
IV-2. Installing the Clamp Attachment .....	4-1
IV-3. Plumbing the Vibro Hoses to the Power Unit .....	4-2
IV-4. Filling Vibrator Pressure Hose .....	4-3
IV-5. Bleeding Clamp Attachment Hydraulic Hoses .....	4-3
IV-6. Precautions and Rules for Operation .....	4-4
IV-7. Relief Valve Settings Prior to Operation - Model 1000 .....	4-5
IV-8. Shut-down Procedures .....	4-5
IV-9. Operation of the Remote Control Pendant .....	4-6
IV-10. Normal Steps to Operate Vibrator .....	4-6
<b>V. MAINTENANCE .....</b>	<b>5-1</b>
V-1. Daily Maintenance Required Prior to Operation .....	5-1
V-2. Checklist After Power Unit Engine Has Started .....	5-1
V-3. Maintenance and Adjustments: ..... <b>(75 Hours)</b> .....	5-2
V-4. Maintenance and Adjustments: ..... <b>(Eccentric Bearings)</b> .....	5-2
V-5. Maintenance and Adjustments in Severe Conditions .....	5-2
V-6. Lubrication .....	5-2
A. Vibratory Gearbox .....	5-2
B. Clamp Attachment .....	5-2



# OPERATION / MAINTENANCE MANUAL

## MODEL 400 TANDEM VIBRATORY HAMMER WITH MODEL 1000 POWER UNITS

7032 So. 196th - Kent, WA. 98032 - (206) 872-0141 / Fax (206) 872-8710

### Table of Contents (Continued...)

#### V. MAINTENANCE (Continued...)

V-7. Power Unit .....	5-3
A. Power Unit Filters, Fluid Types and Capacities .....	5-3
B. Hydraulic Fluid .....	5-4
C. Draining and Filling Hydraulic Fluid Tank .....	5-4
D. Changing Hydraulic Return Filter Element .....	5-5
E. Steps to Remove Filter Element .....	5-5
V-8. Hydraulic Motor - Installation and Start-Up .....	5-6
V-9. Hydraulic Motor Coupling Assembly .....	5-7

#### VI. TROUBLESHOOTING: Model 400 Vibro ..... 6-1

#### VII. MODEL 1000 POWER UNIT ..... 7-1

VII-1. Power Unit Skid .....	7-1
VII-2. Power Unit Systems - General Description .....	7-1
A. Engine Systems .....	7-3
B. Valve Panel .....	7-4
C. Hydraulic Tank .....	7-5
D. Pumps & Pump Drive .....	7-6
E. Hydraulic Circuits & Manifolds .....	7-8
F. Hydraulic Components & Schematic .....	7-17
G. Control Panel & Control Instructions .....	7-19
H. Remote Control Pendant .....	7-27
VII-3. Troubleshooting: Power Unit Electrical .....	7-29
A. Engine Oil Pressure Switch .....	7-29
B. Engine Water Temperature Switch .....	7-29
C. Hydraulic Oil Level Switch .....	7-29
D. Oil Pressure Sending Unit .....	7-30
POWER UNIT ELECTRICAL SCHEMATICS .....	7-31

#### APPENDIX A - CAT 3412 Twin Turbo 1000 HP Engine

A-1. ENGINE OPERATION INSTRUCTIONS .....	A-1
A. Pre-Start Inspection and Procedures .....	A-1
B. Starting The Engine .....	A-2
C. Engine Operation .....	A-3
D. Determining Cause of Shutdown .....	A-7
A-2. MAINTENANCE RECOMMENDATIONS .....	A-9
A. Lubrication Specifications .....	A-10
B. Fuel Specifications .....	A-11
C. Coolant Specifications .....	A-11
D. Lubrication and Maintenance .....	A-12
E. Electrical System .....	A-13
A-3. ENGINE TROUBLESHOOTING .....	A-14



# **OPERATION / MAINTENANCE MANUAL**

## **MODEL 400 TANDEM VIBRATORY HAMMER WITH MODEL 1000 POWER UNITS**

7032 So. 196th - Kent, WA. 98032 - (253) 872-0141 / Fax (253) 872-8710

### **Safety Precautions**

(This list of precautions must be followed at all times to ensure personal & equipment safety.)

1. Read this manual from beginning to end before operating or working on this machine.
2. When operating in a closed area, pipe exhaust fumes outside. (**WARNING:** Breathing exhaust fumes can cause serious injury and even death.)
3. When servicing batteries, avoid any type of spark or open flame. Batteries generate explosive gases during charging. There must be proper ventilation when charging batteries.
4. Never Adjust or repair the unit while it is in operation.
5. Make sure the Control Pendant is in the "**OFF**" position before starting the unit.
6. Remove all tools and electrical cords before starting the unit.
7. Keep oily rags away from the exhaust system.
8. Never store flammable liquids near the engine.
9. Never stand under vibro at any time and keep your eyes on the vibro when it is in operation. Keep a look out for loose bolts or leaking hydraulic lines.
10. Avoid pulling on hose quick dis-connect fittings. Move power unit closer to work if hoses cannot reach. Do not use hoses as a tow line to tug the power unit! If a hose fails at the hydraulic couplers then it is a result of "hose tugging by the pile crew".
11. Avoid kinks in the hoses. Kinks will cut the hose safety factor by 50 percent.
12. Always wear eye and ear protection.
13. Avoid standing downwind of vibrating piles. Dirt and other matter may become airborne and fall into the unprotected eye.
14. Always wear a hardhat, gloves, and safety shoes.
15. Always attach safety line to pile when extracting or hoisting into position.
16. (**WARNING**) Never clamp vibro to pile and dis-connect from crane line. Lay vibro down on ground when not in use.
17. Do not truck power unit with quick disconnect caps and plugs screwed on to fittings unless the caps and plugs have wire rope safety lines attached. Store in storage box under control panel.



# **OPERATION / MAINTENANCE MANUAL**

## **MODEL 400 TANDEM VIBRATORY HAMMER WITH MODEL 1000 POWER UNITS**

7032 So. 196th - Kent, WA. 98032 - (206) 872-0141 / Fax (206) 872-8710

### **Illustration List**

<b>Figure</b>	<b>Title</b>	<b>Page</b>
1-A.	Machine Features .....	1-1
1-B.	General Description of Model 400 Vibro .....	1-3
1-C.	General Description of Suppressor Housing .....	1-4
1-D.	General Description of Vibratory Gearbox .....	1-5
1-E.	General Description of Clamp Attachment .....	1-6
1-F.	Clamp Attachment Hole Configuration .....	1-6
1-G.	Optional Attachments .....	1-7
1-H.	General Description of Model 1000 Power Unit .....	1-8
2-A.	Component Identification .....	2-1
2-B.	Tandem Plate w/ Caisson Beams .....	2-3
2-C.	Caisson Clamp Identification .....	2-4
2-D.	Hose Bundle Identification .....	2-5
2-E.	Model 1000 Power Unit Skid Identification .....	2-7
2-F.	Quick Disconnect Couplings .....	2-8
2-G.	Tool Set Identification .....	2-9
4-A.	Power Unit Coupler Layout .....	4-2
4-B.	Bleeding Clamp Attachment .....	4-3
4-C.	Setting Relief Valve .....	4-4
4-D.	Checking Clamp Pressure Switch Setting .....	4-5
5-A.	Hydraulic Motor - Installation and Start-Up .....	5-6
5-B.	Hydraulic Motor Coupling Assembly .....	5-7

(Chapter 7 List in Work)

<b>Table</b>	<b>Title</b>	<b>Page</b>
<b>Table List</b>		
1-A.	Machine Specifications - Model 400 Vibro .....	1-2
1-B.	Machine Specifications - Model 1000 Power Unit .....	1-2
2-A.	Component Identification .....	2-2
2-B.	Hose Identification .....	2-3
2-C.	Caisson Clamp Identification .....	2-4
2-D.	Model 1000 Power Unit Skid Identification .....	2-5
2-E.	Tool Set Identification .....	2-7
2-F.	Caisson Clamp Wedge Actuator .....	2-8
5-A.	Power Unit - Filters, Fluid Types and Capacities .....	5-3
6-A.	Trouble-Shooting .....	6-1

(Chapter 7 List in Work)



# **OPERATION / MAINTENANCE MANUAL**

**MODEL 400 TANDEM VIBRATORY HAMMER WITH  
MODEL 1000 POWER UNITS**

7032 So. 196th - Kent, WA. 98032 - (253) 872-0141 / Fax (253) 872-8710

## **Warranty**

### **American Piledriving Equipment, Inc. STANDARD WARRANTY**

American Piledriving Equipment, Inc. (APE) warrants new products sold by it to be free from defects in material or workmanship for a period of one year after the date of delivery to the first user and subject to the following conditions:

APE's obligation and liability under this WARRANTY is expressly limited to repairing or replacing at APE's option, any parts which appear to APE upon inspection to have been defective in material or workmanship. Such parts shall be provided at no cost to the user, at the business establishment of APE or the authorized APE distributor of the product during regular working hours. **This WARRANTY, shall not apply to component parts or accessories of products not manufactured by APE** and which carry the warranty of the manufacturer thereof, or to normal maintenance (such as engine tune-up) or normal maintenance parts (such as filters).

Replacement or repair parts installed in the product covered by this WARRANTY are warranted only for the remainder of the warranty as if such parts were original components of said product. AMERICAN PILEDIVING EQUIPMENT, INC. makes no other warranty, expressed or implied and makes no warranty of merchantability of fitness for any particular purpose.

APE's obligation under this WARRANTY shall not include any transportation charges, costs of installation, duty, taxes or any other charges whatsoever, or any liability for direct, indirect, incidental or consequential damage or delay. If requested by APE, products or parts for which a warranty claim is made are to be returned transportation prepaid to APE. Any improper use, including operation after discovery of defective or worn parts, operation beyond rated capacity, substitution of any parts whatsoever, or parts not approved by APE or any alteration or repair by others in such manner as in APE's judgment affects the product materially and adversely, shall void this warranty.

**NO EMPLOYEE OR REPRESENTATIVE IS AUTHORIZED TO CHANGE THIS WARRANTY IN ANY WAY OR GRANT ANY OTHER WARRANTY UNLESS SUCH CHANGE IS MADE IN WRITING AND SIGNED BY AN OFFICER OF APE, INC.**

**ANY TYPE OF WELDING ON EQUIPMENT  
WILL VOID THE WARRANTY**



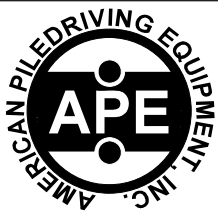

# OPERATION / MAINTENANCE MANUAL

## MODEL 400 TANDEM VIBRATORY HAMMER WITH MODEL 1000 POWER UNITS

7032 So. 196th - Kent, WA. 98032 - (206) 872-0141 / Fax (206) 872-8710

### I. GENERAL INFORMATION

#### I-1. Machine Features. - Model 400 Vibratory Hammer.

Patented breakthrough multi-stage suppressor housing allows variable suppression levels which change to match variable line pull.

The Model 400 out performs other vibros in its class. It is lighter and allows more pull and reach.

The heavy duty lifting pin allows easy rigging of the vibro and two safety lift pins ensure maximum safety.

Up to 250 Tons of line pull! More pulling ability than other comparable vibros.

Shorter overall height and a lower center of gravity.

Gearbox incorporates a machined O-ring groove to seal the top plate with no leaky gaskets.

One piece eccentric/gear design eliminates bolts, keyways, splines and pins.

Rifle bored top plate eliminates more unwanted hoses that can cause serious downtime.

Four eccentrics filled with "heavy metals" produce more amplitude with less parts.

Hydraulic motors are recessed which eliminates the need for bolted on guards. Less parts - less problems. Vertical motor mounting is approved by Rexroth.

Giant spherical bearings are five times larger than those found on other machines.

Computer designed gearbox is perfectly balanced with a very low center of gravity. Release crane line without bending piles.

Heavy clamp cylinders need no guards and all hoses are tucked out of harms way. The one piece design eliminates rear seals, tie rods & nuts.

Gear box drilled to accept attachments manufactured by APE and by other manufacturers.

High speed gear train allows the vibratory Hammer to operate off many different power units.

The 400 vibro can be shipped fully assembled on one truck.

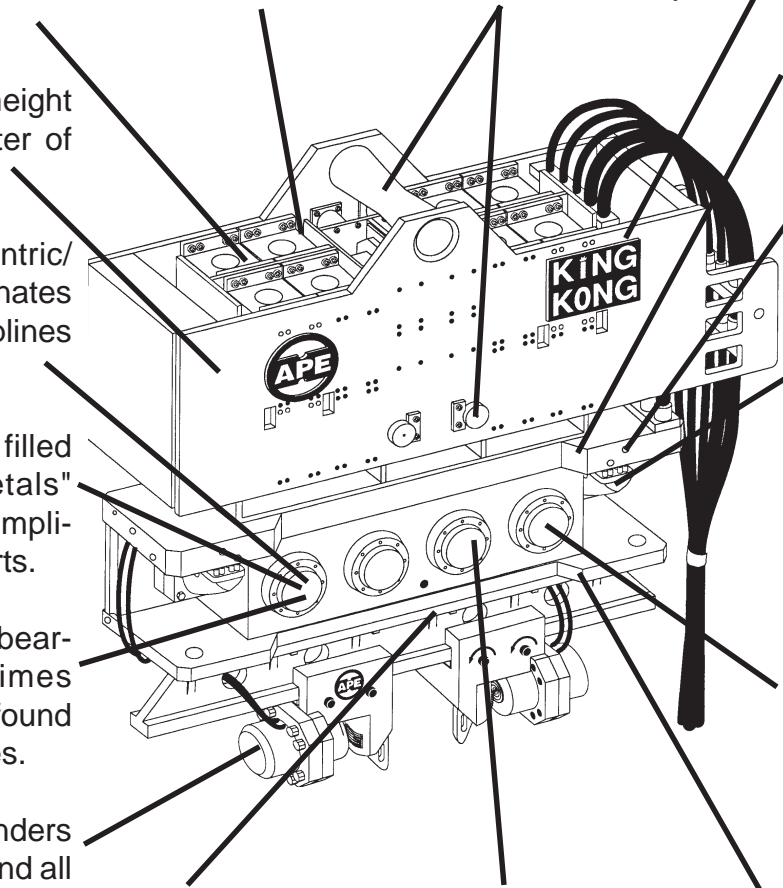

**Figure 1-A. Machine Features**



# **OPERATION / MAINTENANCE MANUAL**

## **MODEL 400 TANDEM VIBRATORY HAMMER WITH MODEL 1000 POWER UNITS**

7032 So. 196th - Kent, WA. 98032 - (253) 872-0141 / Fax (253) 872-8710

### **I. GENERAL INFORMATION (Continued...)**

#### **APE "KING KONG" MODEL 400 VIBRATORY PILE DRIVER/EXTRACTOR**

##### **I-2. Machine Specifications.**

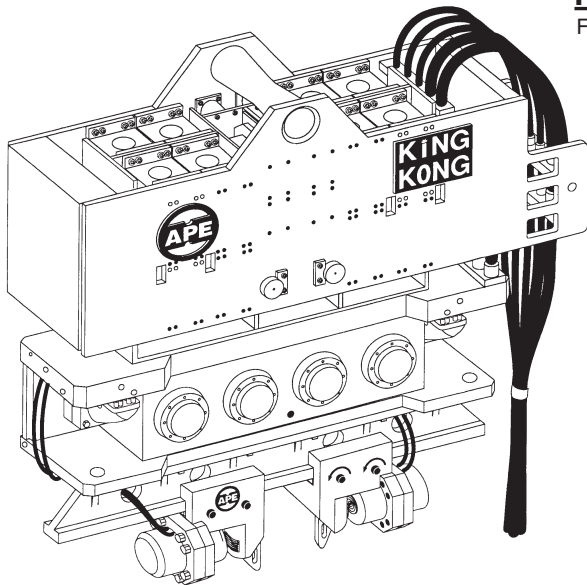

##### **I-2A. Model 400 Vibratory Hammer - (Table 1-A.)**

For driving and extracting heavy caissons, sheets or plates in clay soil conditions.

For current specifications please  
go to: [www.apevibro.com](http://www.apevibro.com)

##### **I-2B. Model 990 Hydraulic Power Unit - (Table 1-B.)**





# **OPERATION / MAINTENANCE MANUAL**

## **MODEL 400 TANDEM VIBRATORY HAMMER WITH MODEL 1000 POWER UNITS**

7032 So. 196th - Kent, WA. 98032 - (206) 872-0141 / Fax (206) 872-8710

### **I. GENERAL INFORMATION (Continued...)**

#### **I-3. General Description of Model 400 Vibro.**

The **APE Model 400** is a variable frequency vibratory pile driver/extractor designed for driving and extracting extremely large caissons, heavy plates, sheet piles, closed-ended pipe piles and concrete piles in difficult soil conditions including clay. The 400 can also be used for soil compaction and pre-boring by displacement method where contaminated soils cannot be removed.

The Model 400 operates in a frequency range of 0 to 1400 cycles per minute depending on the hydraulic flow and on the hydraulic motors fitted to the gear train.

The three major parts to the Model 400 are as follows:

- A.) The Suppressor housing.
- B.) The Gearbox.
- C.) The Clamping Attachment.

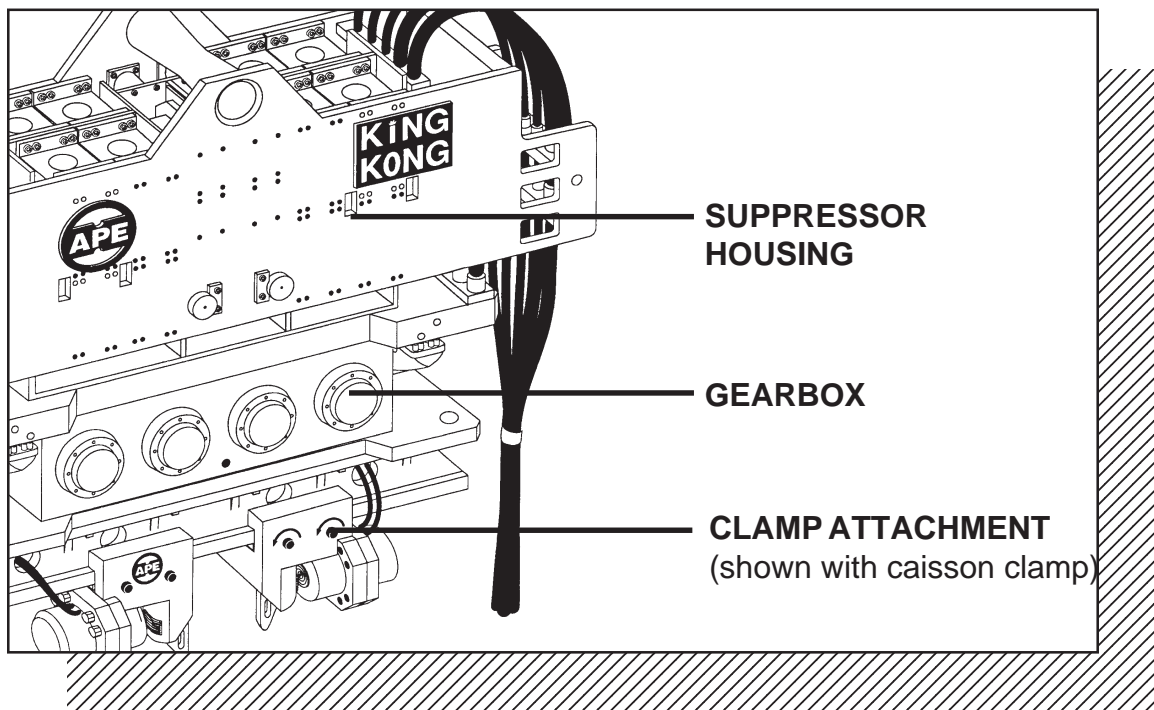

**Figure 1-B. General Description of Model 400 Vibro.**

# OPERATION / MAINTENANCE MANUAL

MODEL 400 TANDEM VIBRATORY HAMMER WITH  
MODEL 1000 POWER UNITS

7032 So. 196th - Kent, WA. 98032 - (253) 872-0141 / Fax (253) 872-8710

## I. GENERAL INFORMATION (Continued...)

### I-3A. The Suppressor Housing.

The suppressor housing of the **Model 400 APE Vibrator** is a patented multi-stage system consisting of up to sixteen large rubber elastomers and eight small elastomers. The large rubber elastomers (technically called the first stage) are used during all driving operations and light to medium extraction. The second stage is made up of eight small high capacity elastomers. During the first stage, two large safety pins travel up with the outer housing as the line pull is increased. The safety pins are then engaged by the lifting bracket which activates the second stage. **(WARNING! Hard pulling for long periods of time will heat and damage the large elastomers. The heat generated from constant heavy line pull will destroy the chemical bond between the rubber and mounting plate which will cause the large elastomer to fail.)** When engaged in hard extracting, break every 15 minutes to allow elastomers to cool.

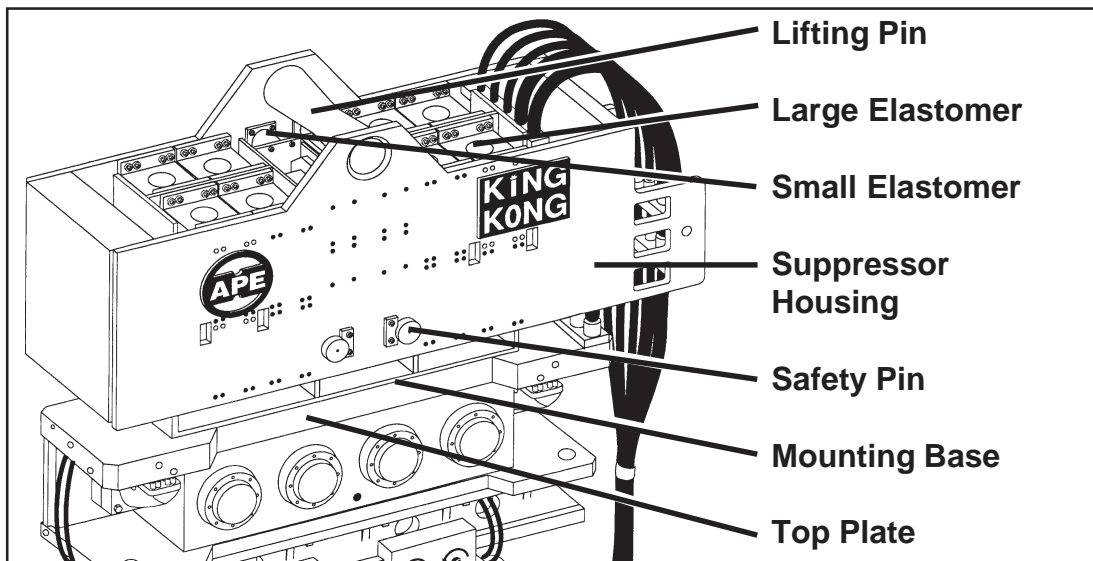

**Figure 1-C. General Description of Suppressor Housing.**

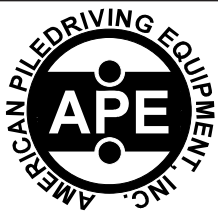

# **OPERATION / MAINTENANCE MANUAL**

**MODEL 400 TANDEM VIBRATORY HAMMER WITH  
MODEL 1000 POWER UNITS**

7032 So. 196th - Kent, WA. 98032 - (206) 872-0141 / Fax (206) 872-8710

## **I. GENERAL INFORMATION (Continued...)**

### **I-3B. The Vibrator Gearbox.**

The vibrator gearbox contains four high amplitude eccentric weights cast in one piece with the gear. This design is unique to the industry and was developed by the engineers of APE to solve a number of problems associated with other types of vibrator machines. Both the eccentric and the drive gears have been helically cut to provide high speed operation with reduced noise and wear. Vibration is caused by the vertical movement created when the eccentrics are rotated. The eccentric and drive gears are all driven in line by two Volvo motors tucked in on the outboard side of the gearbox. The motors are recessed for maximum protection. The eccentrics rotate on four shafts housed by eight giant spherical bearings. The gears and bearings receive lubrication as a result of the fluid splashing inside the gearbox when the gears are rotated. The oil level is quickly determined by looking at the site gauge. The Model 400 can be operated under water to a depth of 30 feet without modifications. (Consult factory for depths below 30 feet.)

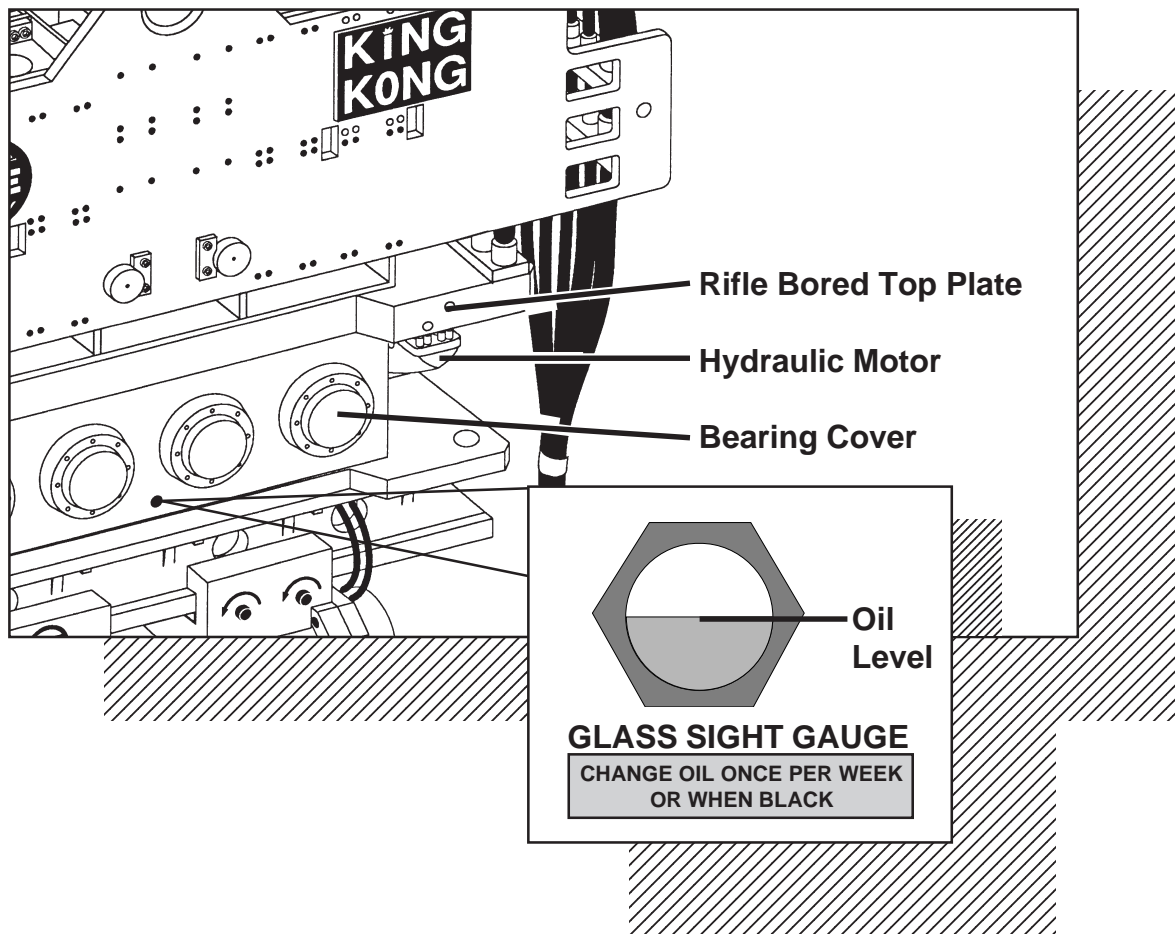

**Figure 1-D. General Description of Vibrator Gearbox.**



# OPERATION / MAINTENANCE MANUAL

## MODEL 400 TANDEM VIBRATORY HAMMER WITH MODEL 1000 POWER UNITS

7032 So. 196th - Kent, WA. 98032 - (253) 872-0141 / Fax (253) 872-8710

### I. GENERAL INFORMATION (Continued...)

#### I-3C. The Clamp Attachment.

The APE Model 400 Tandem comes with a **Tandem Plate, Caisson Beam and Caisson Clamps**. The clamps contain two gripping jaws. One is "fixed" and one is "moveable." A large hydraulic cylinder operates the moveable jaw with up to 250 tons of clamping force depending on clamp pump relief pressure. The jaws open and close by turning a switch on the remote control pendant or may be operated by turning the switch at the main control panel mounted behind one of the doors on the power unit. The valve can be manually operated with a screwdriver if all electrical fails. **The APE Caisson Clamp** can be used for driving and extracting caissons from 16 inches to 11 feet. The one piece cast beam will not bend or break and was designed to be compatible with all types of vibros. The heavy duty design of the clamp cylinders eliminates the need for cylinder guards. The clamps are held in place on the beam with a simple wedge-lock design. (Clamps can be fitted with hydraulically activated wedges for faster adjustments when driving more than one size caisson. Please call the factory for more information on clamp attachments for special pile types.)

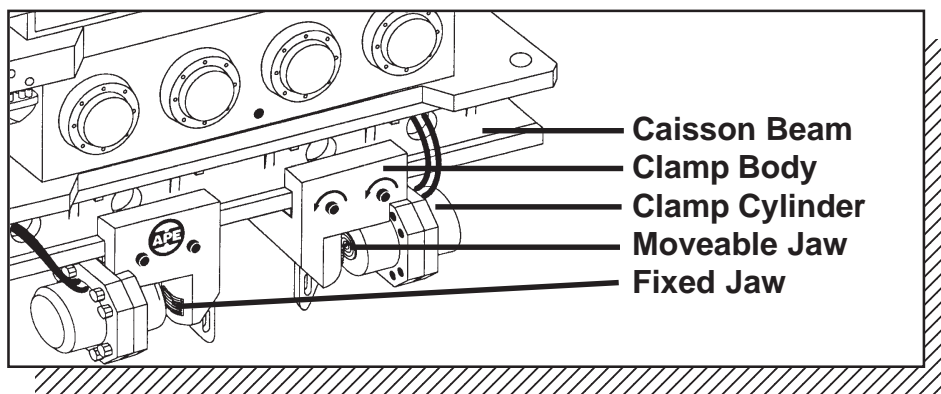

**Figure 1-E. General Description of Clamp Attachment.**

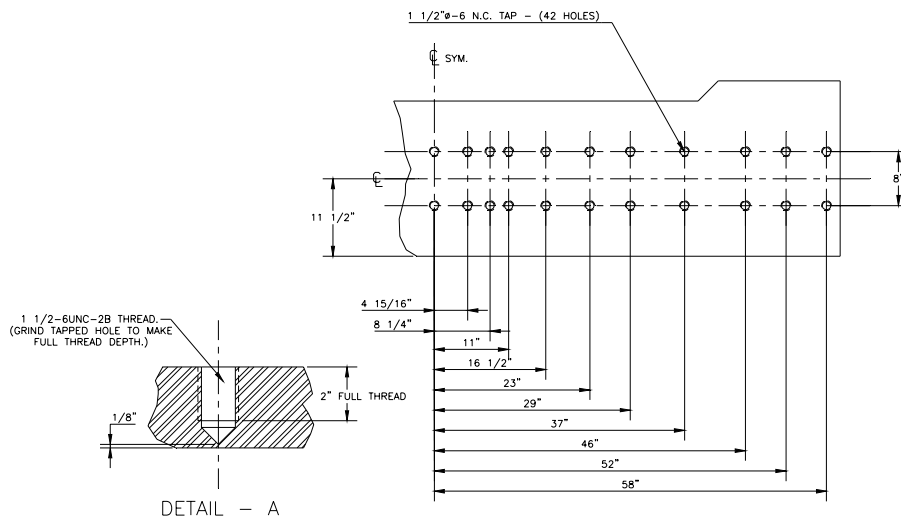

**Figure 1-F. Clamp Attachment Hole Configuration**



# OPERATION / MAINTENANCE MANUAL

MODEL 400 TANDEM VIBRATORY HAMMER WITH  
MODEL 1000 POWER UNITS

7032 So. 196th - Kent, WA. 98032 - (206) 872-0141 / Fax (206) 872-8710

## I. GENERAL INFORMATION (Continued...)

### I-3D. Optional Attachments.

The following are some of the optional attachments for the Model 400 Vibratory hammer. (Contact APE or your local APE distributor for more information about these and other available equipment.)

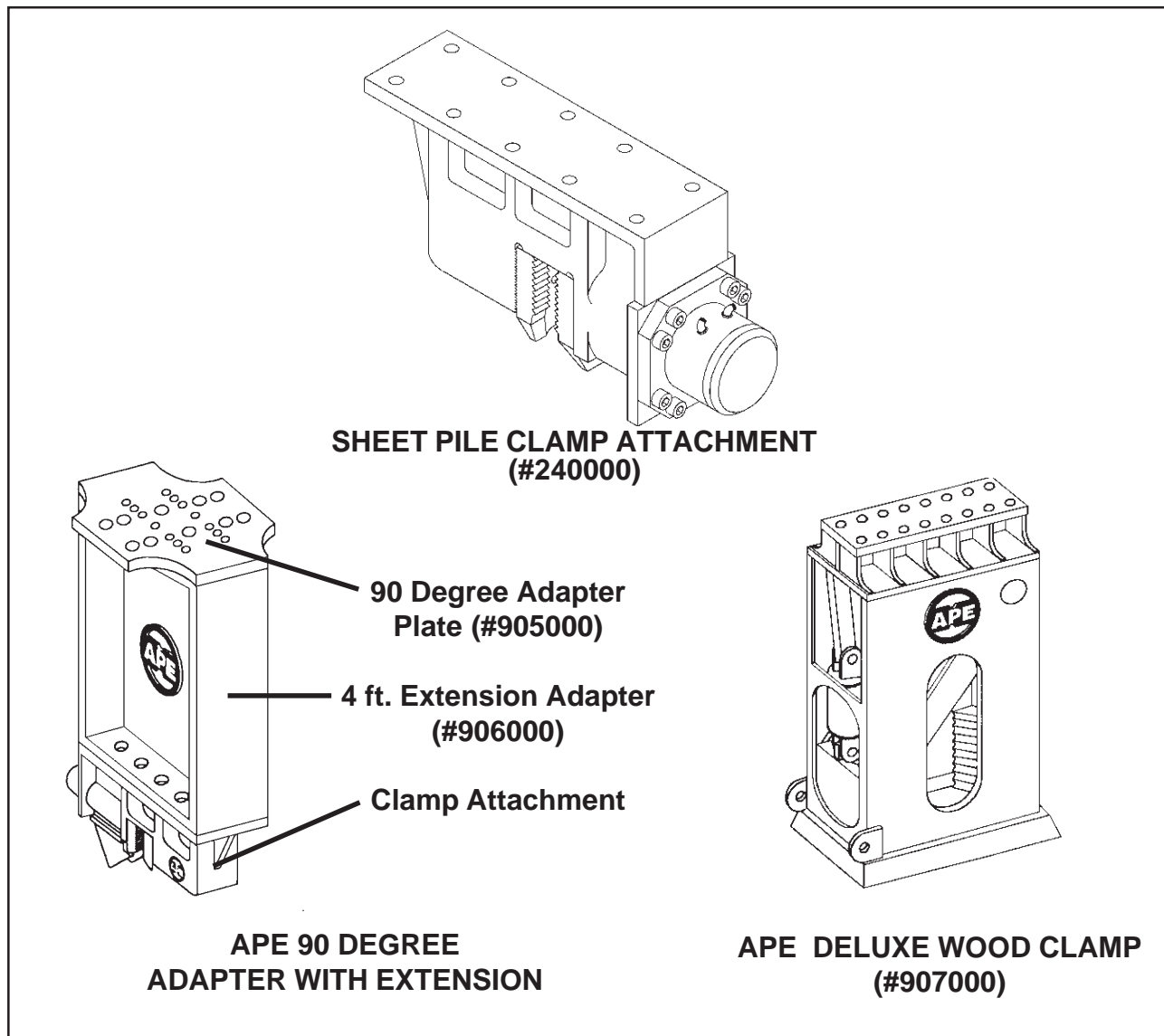

**Figure 1-G. Optional Attachments**

# OPERATION / MAINTENANCE MANUAL

## MODEL 400 TANDEM VIBRATORY HAMMER WITH MODEL 1000 POWER UNITS

7032 So. 196th - Kent, WA. 98032 - (253) 872-0141 / Fax (253) 872-8710

### I. GENERAL INFORMATION (Continued...)

#### I-4. General Description of Model 1000 Power Unit

The Model 400 vibrator runs off the APE 1000 power unit. The APE 1000 has a CAT 3412E Twin Turbo 1000 horsepower engine. The engine is mounted to a tubular frame that also serves as a diesel fuel tank. A sheet metal and tube frame covers the engine and is equipped with locking doors for protection from the environment. A control panel is located behind one of the doors and comes complete with a 50 foot control pendant. There are two hydraulic tanks on the power unit. One is the main tank and the other is a storage tank for extra oil in case the main tank becomes depleted. A hydraulic tank supplies oil to five pumps. Three pumps feed the two vibrator motors. One pump is used for continuous recirculation of hydraulic oil. A small pump feeds the clamp attachment. The Vibrator is connected to the power unit via five hydraulic hoses. The two large 2" hoses are the pressure and return lines for the vibrator motors. The two smaller 3/8" hoses are for the clamp system, and one 1 1/4" hose is for the vibrator motor case drain line. The hoses are attached to the power unit by connecting the "quick dis-connect fittings" (QD's) on the end of the hoses leading from the vibrator. The fittings go on only one way so there is no chance of hooking up the hoses improperly.

**WARNING:** Clean with ether or a clean rag before installing quick disconnects. Make sure you seat the quick disconnect fittings all the way tight. Failure to tighten the quick disconnects will stop the flow of oil and will prevent the vibro from operating. Failure to tighten the clamp fittings completely tight will cause the jaws to either not open or not close. If this happens you may have to crack the fitting and bleed off the pressure to release the quick dis-connects.

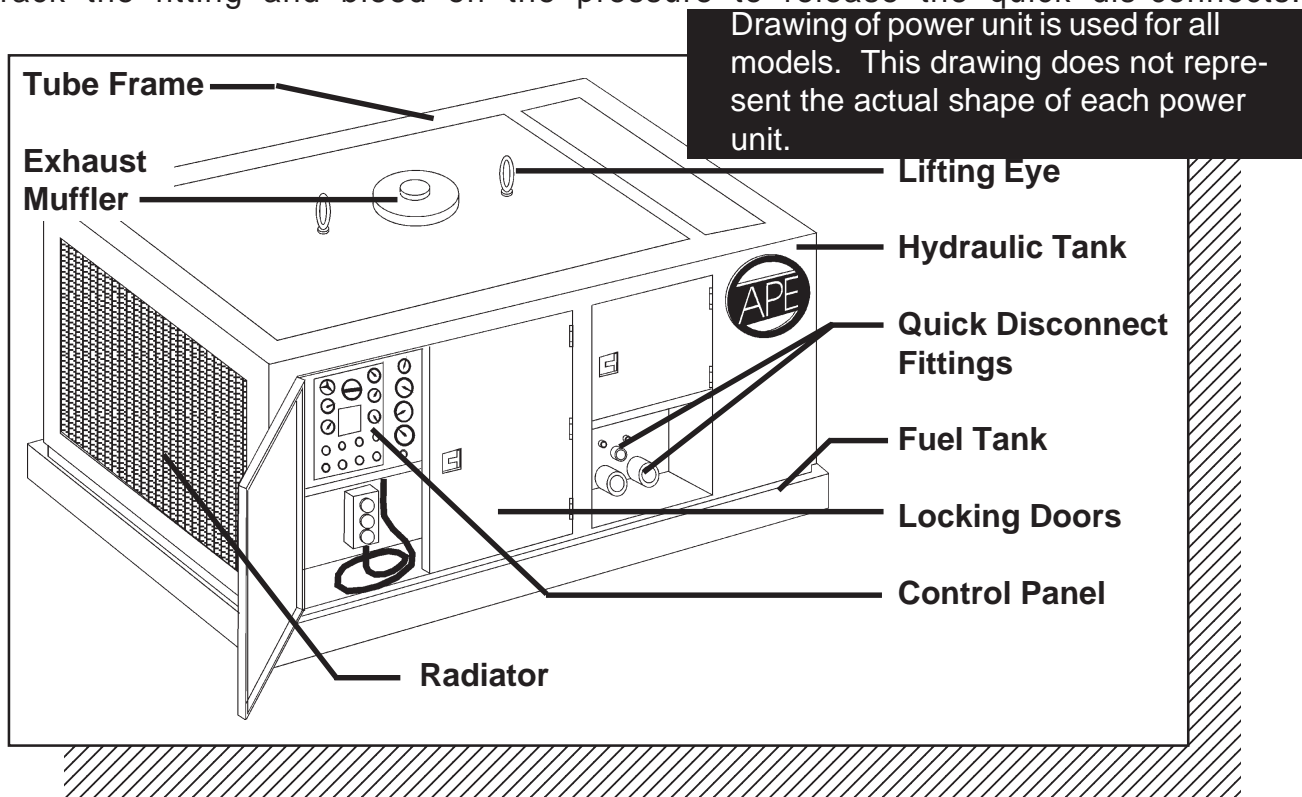

**Figure 1-H. General Description of Model 990 Power Unit**





# OPERATION / MAINTENANCE MANUAL

## MODEL 400 TANDEM VIBRATORY HAMMER WITH MODEL 1000 POWER UNITS

7032 So. 196th - Kent, WA. 98032 - (206) 872-0141 / Fax (206) 872-8710

### II. MAJOR COMPONENT DEFINITION

#### II-1. Component Identification - Model 400 Vibratory Hammer.

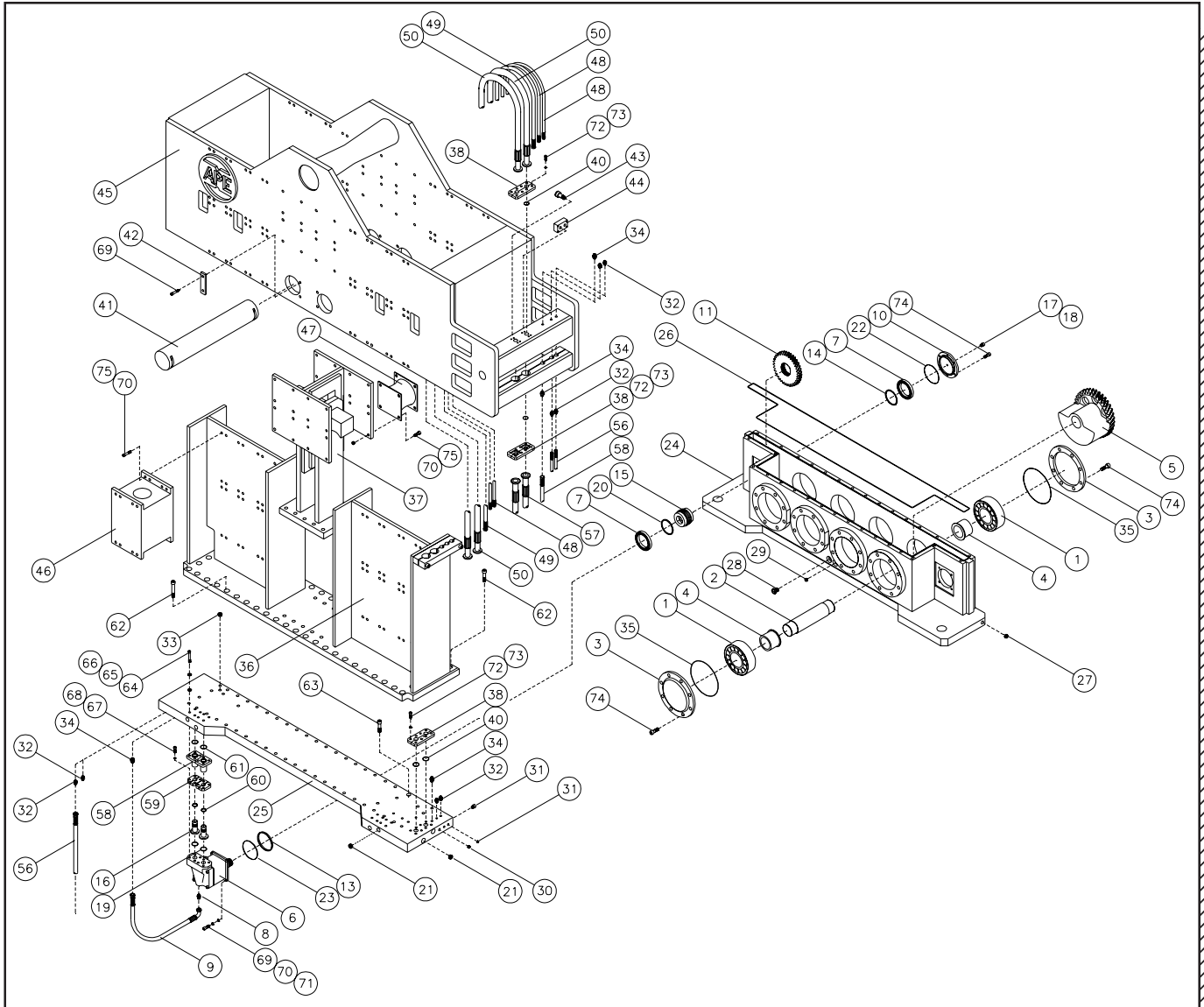

**Figure 2-A. Component Identification - Model 400 Vibratory Hammer.**



# OPERATION / MAINTENANCE MANUAL

## MODEL 400 TANDEM VIBRATORY HAMMER WITH MODEL 1000 POWER UNITS

7032 So. 196th - Kent, WA. 98032 - (253) 872-0141 / Fax (253) 872-8710

### II. MAJOR COMPONENT DEFINITION (Continued...)

#### II-1. Component Identification.

The following is a general listing of the APE Model 400 Major components and part numbers. (Please see Figure 2-A. for component location.)

**Table 2-A. Component Identification.**

Item	Qty	Description	Part #
1	8	Model 400 Eccentric Bearing	#141001
2	4	Eccentric Shaft	#141003
3	8	Eccentric Bearing Cover	#141004
4	8	Eccentric Bearing Sleeve	#141005
5	4	Eccentric Weight - Model 400	#141007
6	2	Vibratory Motors	#142001
7	2	Motor Bearing	#142002
8	2	Fitting #F40X-S-812MJICxMBSPP	#142003
9	2	Motor Hose Assembly	#142004
10	2	Motor Bearing Cover	#142005
11	1	Drive Gear - Left	#142006
12	1	Drive Gear - Right	#142007
13	2	Bearing Spacer	#142008
14	4	Gear Spacer	#142009
15	2	Gear Carrier	#142010
16	4	Hydraulic Motor Adapter	#142018
17	1	#10 SAE Breather Plug	#122014
18	1	Breather Valve	#122015
19	4	Parker O-Ring #2-225	#122027
20	2	Gear Spacer (Narrow)	#142011
21	8	#32 SAE Socket Drive Plug	#143007
22	2	Motor Cover O-Ring #2-258	#142019
23	2	Motor O-Ring #2-163	#142020
24	1	Vibratory Gearbox	#143001
25	1	Top Plate	#143002
26	1	.070 C/S BUNA 70 CORD O-Ring	#143003
27	2	Magnetic Drain Plug	#123004
28	1	Sight Gauge	#123005
29	1	Gearbox Oil Level Plug	#123006
30	2	#20 SAE Socket Drive Plug	#123007
31	8	#8 SAE Socket Drive Plug	#123008
32	2	#8 SAE / #6 JIC Fitting	#123009
33	1	Oil Fill Plug	#123012
34	2	#12 SAE / #12 JIC Fitting	#123013
35	8	Bearing Cover O-Ring #2-276	#141008
36	1	Suppressor Mounting Base	#340102
37	1	Lifting Bracket	#340103
38	3	Double Split Flange	#123018
39	1	Bolt Kit	#144000
40	6	Flange O-Ring #2-225	#143020
41	2	Center Pin	#341006
42	2	Keeper Plate	#341007
43	1	Pop-Off Valve	#321009
44	1	Check Valve	#321015
45	1	Suppressor Housing	#340101
46	16	Large Elastomers	#321003
47	8	Small Elastomers	#321004

Item	Qty	Description	Part #
48	2	Hose, Suppressor, Clamp 3/8" 3 Wire x 12' w/6-6FJX ea. end.	#440103
49	1	Hose, Suppressor, Case Drain 1 1/4" 100R2AT x 12' Coupled HL20-20NJ ea. end.	#440102
50	2	Hose, Suppressor, Motor Feed 2" 100R13 x 12' Coupled ER32-32PH ea. end.	#440101
56	6	Hose, Clamp Line 3/8" 3 Wire x 6' w/6-6FJX ea. end.	#421004
57	2	Hose, Pigtail, 2" 100R13 x 6' ER32-32PH & ER32-32NJ ea. end.	#441007
58	4	Hydraulic Flange Coupling	#142012
59	4	Hydraulic Motor Split Flange	#142017
60	4	Parker "Polypak" #18701750-375	#142019
61	4	Parker O-Ring #2-332	#142020
62	---	Bolt-SHCS 3/4"NC x 6"	#144104
63	---	Bolt-SHCS 3/4"NC x 2 1/4"	#144303
64	---	Bolt-SHCS 7/16" x 4 1/2"	#144108
65	---	Flat Washer - 7/16"	#144110
66	---	Lock Washer - 7/16" High Collar	#144111
67	---	Bolt M14 x 30	#144112
68	---	Lock Washer M14	#144117
69	---	Bolt-SHCS 3/4"NC x 1 1/2"	#144101
70	---	Flat Washer - SAE 3/4"	#144305
71	---	Lock Washer 3/4" High Collar	#144105
72	---	Bolt-SHCS 5/8"NC x 2"	#144114
73	---	Lock Washer 5/8" High Collar	#144115
74	---	Bolt-SHCS 1/2"NC x 1"	#144107
75	---	Bolt-SHCS 3/4"NC x 2 1/4"w/Nut	#144303
76	-	-	#
77	-	-	#
78	-	-	#
79	-	-	#
80	-	-	#
81	-	-	#
82	-	-	#
83	-	-	#
84	-	-	#
85	-	-	#
86	-	-	#
87	-	-	#
88	-	-	#
89	-	-	#
90	-	-	#



# OPERATION / MAINTENANCE MANUAL

MODEL 400 TANDEM VIBRATORY HAMMER WITH  
MODEL 1000 POWER UNITS

7032 So. 196th - Kent, WA. 98032 - (206) 872-0141 / Fax (206) 872-8710

## II. MAJOR COMPONENT DEFINITION

### II-2. Tandem Plate w/ Caisson Beams.

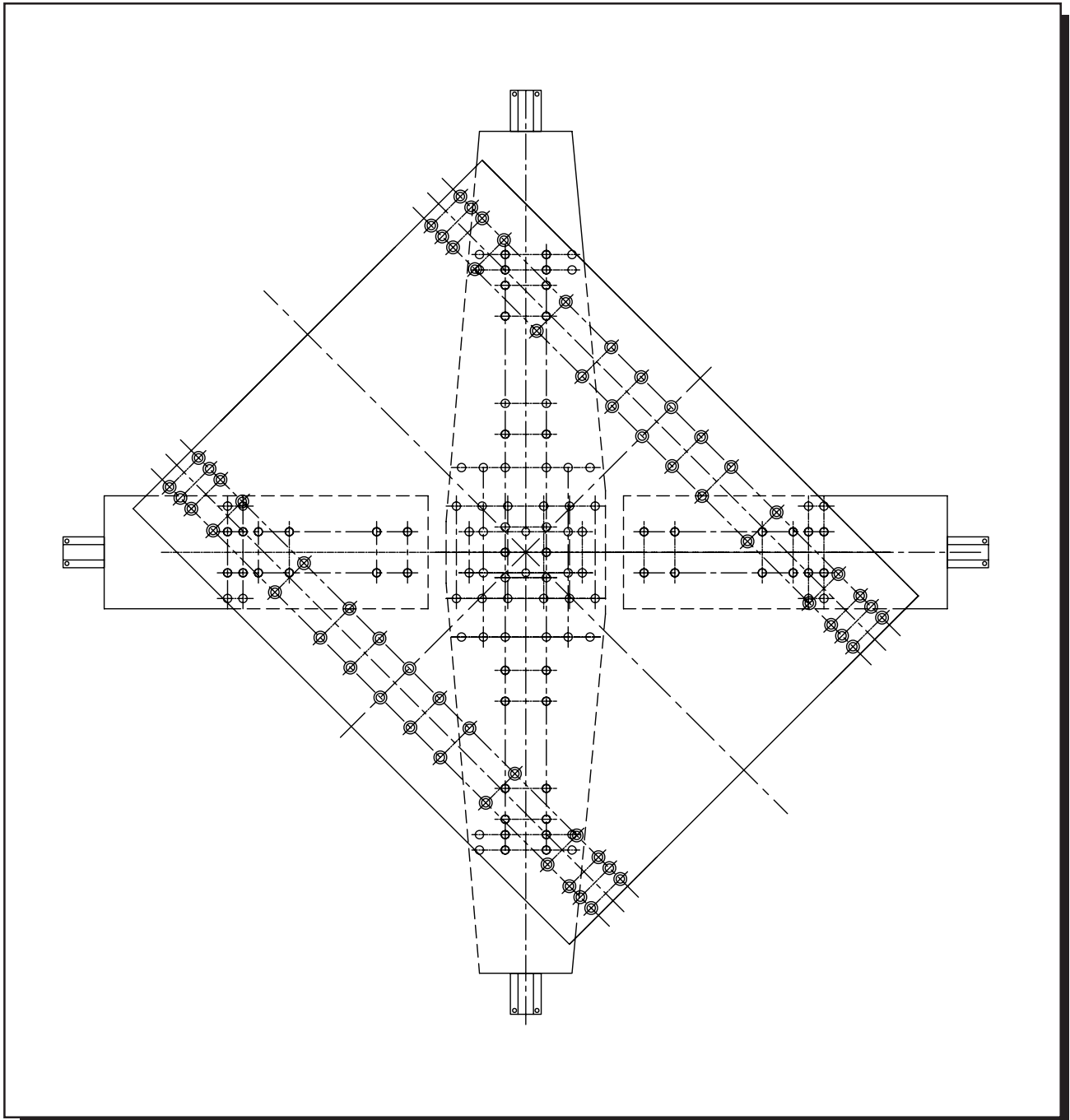

**Figure 2-B. Tandem Plate w/ Caisson Beams**



# OPERATION / MAINTENANCE MANUAL

## MODEL 400 TANDEM VIBRATORY HAMMER WITH MODEL 1000 POWER UNITS

7032 So. 196th - Kent, WA. 98032 - (253) 872-0141 / Fax (253) 872-8710

### II. MAJOR COMPONENT DEFINITION (Continued...)

#### II-3. Caisson Clamp Identification.

The following is a general listing of the parts for the APE Caisson Clamp and Beams. (Please see Figure 2-C. for component location.)

**Table 2-C. Caisson Clamp Identification**

Item	Qty	Description	Part #
1	1	Caisson Clamp Body	#250101
2	6	Grease Zert	#221001
3	1	Caisson Clamp Plunger/Jaw	#250301
4	1	Caisson Clamp Fixed Jaw	#250202
5	2	Bolt - SHCS 5/8" x 4"	#124214
6	2	Lock Washer 5/8" High Collar	#124115
7	2	Male Wedge Half	#243102
8	2	Female Wedge Half	#243105
9	2	Wedge Bolt w/Washer	#124211
10	2	Wedge Nut w/Washer	#124212
11	17	Bolt - SHCS 1 1/2" x 3 1/2"	#124201
12	17	Lock Wa. - 1 1/2" High Collar	#124202
13	1	Clamp Cylinder	#250001
14	2	#6 SAE/#6 JIC 45 Deg. Fitting	#222002
15	8	Bolt - SHCS 1 1/4"NFx3 1/2"GR.8	#124204
16	8	Lock Wa. - 1 1/4"High Collar	#124205
17	1	Cylinder End Cap	#250302

Item	Qty	Description	Part #
18	1	Cylinder Piston	#250303
19	1	Plunger	#250301
20	1	Bolt -SHCS 1 1/2-8 x 3"	#250304
21	1	Wiper - #959-41	#
22	1	Caisson Beam 11ft.	#903000
23	1	Poly Seal - #2500-4500-375B	#
24	12	Bolt - SHCS 5/8-18 x 1"	#
25	8	Spring Pin	#250103
26	4	Wedge Spring	#250104
27	1	Wear Ring - #W2-4750-750	#
28	1	Hydraulic Wedge Activator Kit	#243100
29	1	Parker O-Ring #8-367	#
30	1	Parker O-Ring #2-367	#
31	1	Piston O-Ring #2-338	#
32	1	Piston Wear Ring #W2-8000-750	#
33	1	TFER8000 Bronze w/Loader Ring	#
34	1	Square Ring - #4426	#

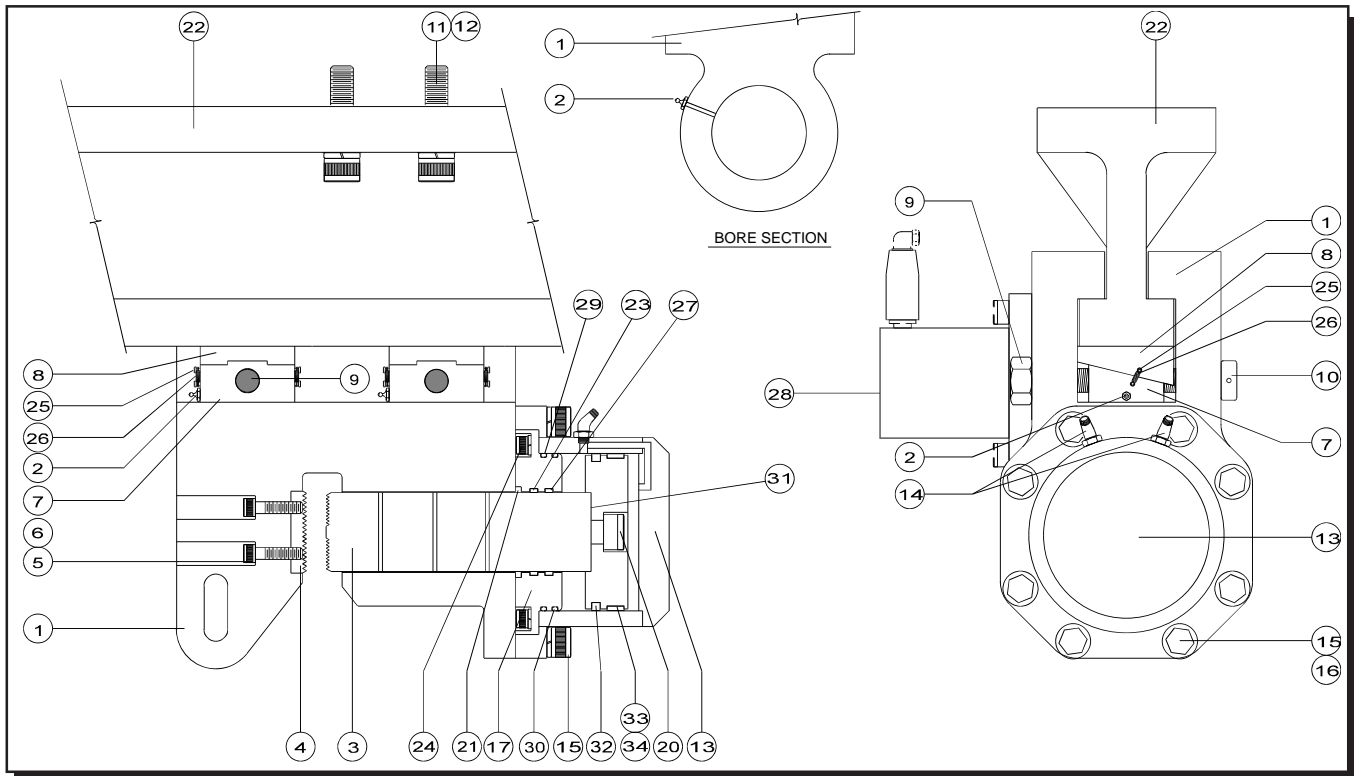

**Figure 2-C. Caisson Clamp Identification.**

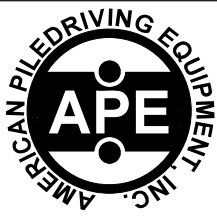

# OPERATION / MAINTENANCE MANUAL

MODEL 400 TANDEM VIBRATORY HAMMER WITH  
MODEL 1000 POWER UNITS

7032 So. 196th - Kent, WA. 98032 - (206) 872-0141 / Fax (206) 872-8710

## II. COMPONENT DEFINITION (Continued...)

### II-4. Hose Identification.

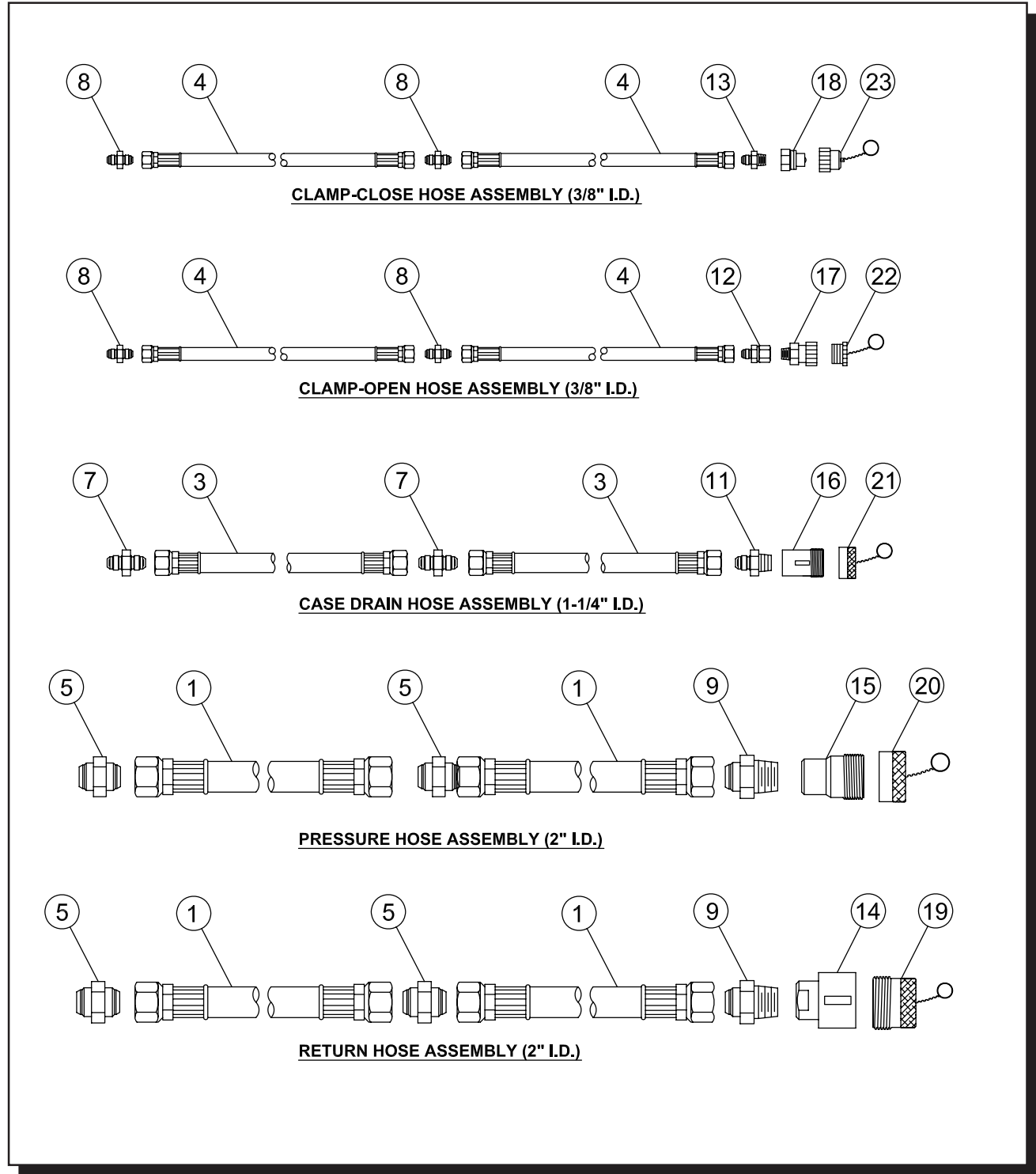

**Figure 2-D. Hose Bundle Identification - Vibro.**



# OPERATION / MAINTENANCE MANUAL

## MODEL 400 TANDEM VIBRATORY HAMMER WITH MODEL 1000 POWER UNITS

7032 So. 196th - Kent, WA. 98032 - (253) 872-0141 / Fax (253) 872-8710

### II. COMPONENT DEFINITION (Continued...)

#### II-4. Hose Identification (Continued...)

The following is a general listing of the standard hoses bundles that are shipped with the Model 400 Vibratory Driver. (Please see Figure 2-B. for component location.)

**Table 2-B. Hose Identification - Bundle (APE P/N 441000)**

Item	*Qty	Description	Part No.
1	6	2" x 50' c/w 2" FJIC e/e (5000 psi rated)	#421008
3	3	1-1/4" x 50' c/w 1" FJIC e/e (2000 psi rated)	#421036
4	6	3/8" x 50' c/w 3/8" FJIC e/e (CPB 5500 psi)	#421010
5	3	Fitting #32 Male JIC Union	#421048
7	3	Fitting #20 Male JIC Union	#421037
8	6	Fitting #6 Male JIC Union	#421014
9	1	Fitting #32 MJIC/#32 M. Pipe	#421049
11	1	Fitting #20 MJIC/#20 M. Pipe	#421016
12	1	Fitting #6 MJIC/#6 F. Pipe	#421011
13	1	Fitting #6 MJIC/#6 M. Pipe	#421017
14	1	2" QD Female Coupling	#441301
15	1	1-1/2" QD. Male Coupling	#400303
16	1	Aeroquip Male QD #5100S112B	#421020
17	1	Safeway Female QD #S35-3	#421024
18	1	Safeway Male QD #S31-3	#421025
19	1	APE 2" Dust Plug	#441103
20	1	APE 2" Dust Cap	#441104
21	1	Aeroquip Dust Cap #5100S712B	#421021
22	1	Safeway Plug #S34-3	#421027
23	1	Safeway Cap #S39-3	#421026
*Note: Qty per vibro			



# OPERATION / MAINTENANCE MANUAL

## MODEL 400 TANDEM VIBRATORY HAMMER WITH MODEL 1000 POWER UNITS

7032 So. 196th - Kent, WA. 98032 - (206) 872-0141 / Fax (206) 872-8710

### II. MAJOR COMPONENT DEFINITION (Continued...)

#### II-5. Model 1000 Power Unit Skid Identification.

Table 2-D. Model 1000 Power Unit Skid Identification

Item	Qty	Description
1	1	Model 1000 Power Unit Skid
2	1	Radiator Grill
3	1	Door 28 1/4" x 85 1/2"
4	1	Door 21 1/2" x 85 1/2"
5	1	Door 21 1/2" x 85 1/2"
6	1	Door 24 7/8" x 85 1/2"
7	1	Door 29 1/2" x 85 1/2"
8	1	Door 25 1/2" x 50 1/2"
9	2	2" Hydraulic Coupling
10	1	1 1/4" Hydraulic Coupling
11	2	3/8" Hydraulic Coupling
12	10	Door Handle / Lock
		Lock-#EMC 56462W Two Point Lock
		Handle-#EMC 48742W Locking Handle
13	29	Hinges #R140-150 Weld On Hinge
14	2	Lifting Eye Nuts - Crosby Laughlin #6-400 #10
15	1	Cover Plate 12" x 15"
16	1	Cover Plate 15" x 18"
17		
18		
19		
20	1	APE Dust Plug #441103
21	1	APE Dust Cap #441104



Figure 2-E. Model 1000 Power Unit Skid Identification.



# OPERATION / MAINTENANCE MANUAL

## MODEL 400 TANDEM VIBRATORY HAMMER WITH MODEL 1000 POWER UNITS

7032 So. 196th - Kent, WA. 98032 - (253) 872-0141 / Fax (253) 872-8710

### II-6. Quick Disconnect Couplings. - Figure 2-F.

The 5TV series high pressure hydraulic coupling is designed for rugged hydrostatic drive applications in the mining and oil industries. Service in many such applications has proven the design compatible to extreme pressures, structural and system induced shockloads. The construction makes the coupling attractive in applications having low operating pressures. **NOTE - Not for use with gaseous fluids.**

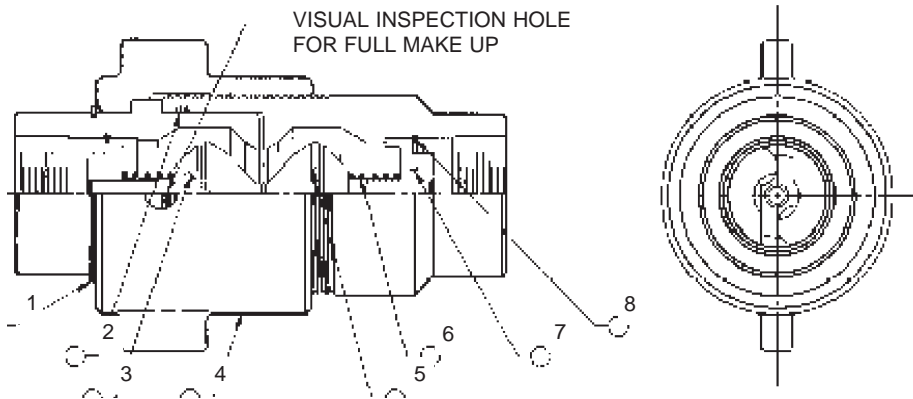

Figure 2-E. Quick Disconnect Coupling Identification.

- 1 NUT RETAINER RING
- 2 NIPPLE SEAL (O-RING/BACK UP RING)
- 3 POPPET VALVE
- 4 HIGH STRENGTH CAST STEEL NUT

- 5 VALVE SEAL SWAGED IN AGAINST WASHOUT
- 6 VALVE SPRING
- 7 EXCLUSIVE FOUR POINT CONTACT POPPET GUIDE
- 8 2-TURN LOCK RING

#### OPERATING LIMITS

- 5,000 P.S.I. operating pressure - all sizes
- 20,000 P.S.I. minimum burst - coupled
- Vacuum to 28" Hg
- Standard seal - temperature range -65OF to +250OF
- Buna-N seals - standard

#### DESIGN FEATURES

- Excellent flow characteristics for continuous duty applications. See flow chart.
- High strength steel poppet guides prevent break up and washout of coupling valving during high surge and shock conditions.
- Exclusive four point support design of poppet guide provides positive alignment of valving during surging flow conditions.
- Flat crested stub-acme threads and all steel construction withstand storage and rig-up damage.
- Protective treatment equal to industry standards for SAE steel hose fittings.
- Structurally compatible with weight of 5,000 P.S.I. flex-hose and system induced shockloads.

#### SIZES AND CONNECTION TYPE

- 3/4" thru 3' - female NPTF pipe thread

#### PRESSURE DROP vs FLOW (GPM) - COUPLING

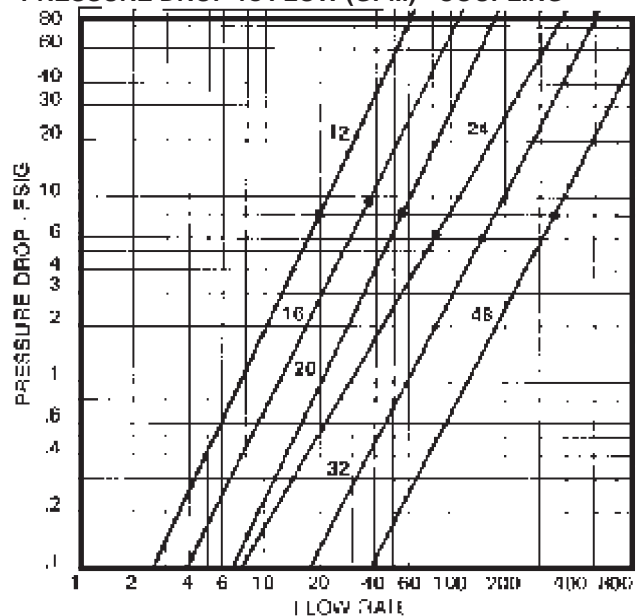

- Pressure drop thru coupling based on flow giving 15 FPS fluid velocity thru nominal bore size.

COUPLING PART NO.	DUST PLUG PART NO.	DUST CAP PART NO.	VALVE ASS'Y PART NO.	NIPPLE SEAL PART NO.
5TV-CN-32	5TV-DP-32	5TV-DC-32	5TV-VA-32	5TV-NS-32



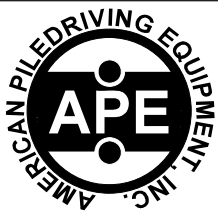

# OPERATION / MAINTENANCE MANUAL

## MODEL 400 TANDEM VIBRATORY HAMMER WITH MODEL 1000 POWER UNITS

7032 So. 196th - Kent, WA. 98032 - (206) 872-0141 / Fax (206) 872-8710

### II. MAJOR COMPONENT DEFINITION (Continued...)

#### II-7. Tool Set Identification.

Mounted inside the **Model 1000 Power Unit** is a set of tools frequently used for the maintenance of the **APE Model 400 Vibratory Hammer**. The following figure and table shows the location and the use for each tool.

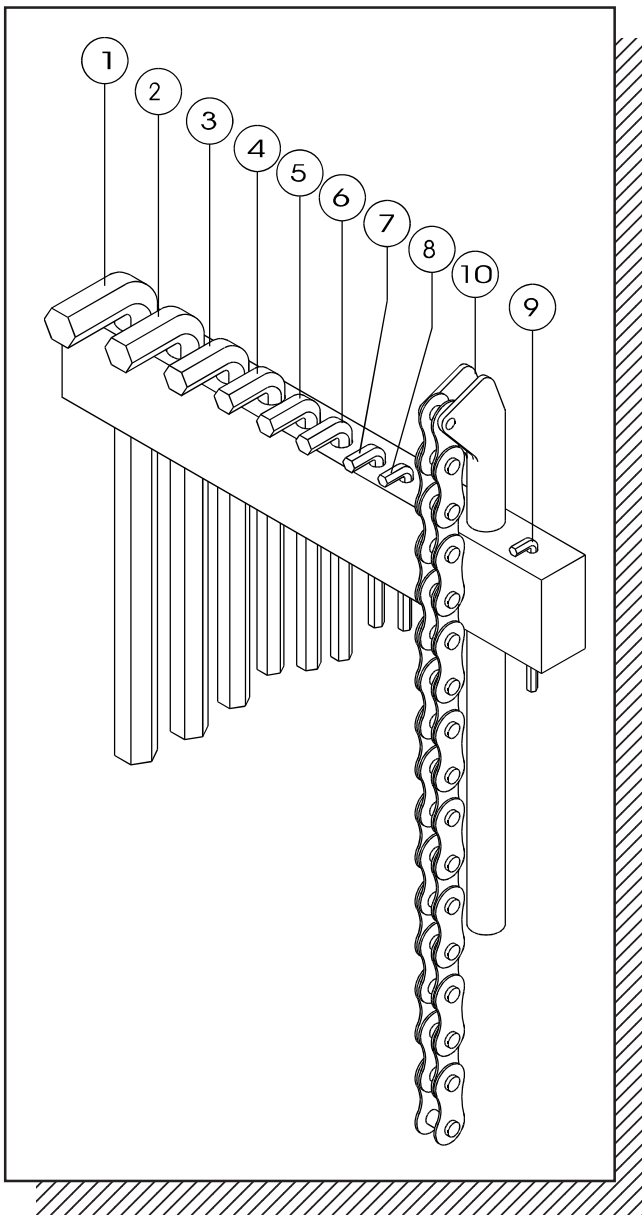

**Figure 2-G. Tool Set Identification.**

**Table 2-E. Tool Set Identification.**

ITEM	QTY	DESCRIPTION	PART#
1	1	1" Allen Wrench	#950002
For use with the clamp attachment bolts			
2	1	7/8" Allen Wrench	#950003
For use with the drain plug & sheet guide			
3	1	3/4" Allen Wrench	#950004
For use with the clamp fixed jaw bolts			
4	1	5/8" Allen Wrench	#950005
For use with the hydraulic motor mnt. bolts			
5	1	9/16" Allen Wrench	#950011
For use with the hose bracket bolts			
6	1	1/2" Allen Wrench	#950006
For use with the suppressor top plate bolts			
7	1	3/8" Allen Wrench	#950007
For use with the bearing cover bolts			
8	1	5/16" Allen Wrench	#950012
For use with the hose bracket bolts			
9	1	Chain Wrench	#950009
Used to tighten the quick disconnects			
10	1	1/4" Allen Wrench	#950013
For use with the vibro oil level check			



# **OPERATION / MAINTENANCE MANUAL**

**MODEL 400 TANDEM VIBRATORY HAMMER WITH  
MODEL 1000 POWER UNITS**

7032 So. 196th - Kent, WA. 98032 - (253) 872-0141 / Fax (253) 872-8710

## **II. MAJOR COMPONENT DEFINITION (Continued...)**

**THIS PAGE INTENTIONALLY BLANK**



# **OPERATION / MAINTENANCE MANUAL**

## **MODEL 400 TANDEM VIBRATORY HAMMER WITH MODEL 1000 POWER UNITS**

7032 So. 196th - Kent, WA. 98032 - (206) 872-0141 / Fax (206) 872-8710

### **III. LOADING AND UNLOADING**

#### **III-1. Model 400 Vibratory Hammer.**

The APE Model 400 vibrator is normally shipped standing up on the trailer deck with the beam and clamps removed and the hose bundle coiled next to it. Lift the vibrator by rigging one line to the lifting pin lifting the vibro and hose bundle as one load. Avoid smashing hydraulic lines. Vibro should be loaded standing as mentioned earlier. Before the truck has left, carefully inspect the machine and hoses for any missing equipment or sign of damage that may have occurred during shipment or unloading.

#### **III-2. Model 1000 Power Unit.**

The Power Unit is always loaded with the oil cooler facing to the rear of the truck to prevent damage to the cooler and the radiator from flying objects. The Power Unit is usually held to the truck by wrapping a chain around both ends of the fuel tank base and the truck bed. After loading the Power Unit, tape the exhaust rain cap shut to prevent rain water from getting inside. If quick disconnects do not have safety cables then store them under the panel in the storage box rather than risk the possibility of the caps and plugs coming loose and falling off into traffic. Make sure all doors are fully closed. Tighten fuel cap to prevent diesel fuel from washing out the fill spout.

#### **III-3. What to do if damaged during shipment.**

In the event of damage, notify the shipping agent immediately. Note all damage on the bill of lading. Fax the information as soon as possible; any delay may make it impossible to find the responsible party.



# **OPERATION / MAINTENANCE MANUAL**

## **MODEL 400 TANDEM VIBRATORY HAMMER WITH MODEL 1000 POWER UNITS**

7032 So. 196th - Kent, WA. 98032 - (253) 872-0141 / Fax (253) 872-8710

### **IV. PREPARATION AND OPERATION**

#### **IV-1. Rigging of Vibratory Hammer**

A steel wire rope sling must be connected to the lifting bail located on top of the vibro. The required strength of this sling depends on the capacity of the crane and the work to be carried out. A safety factor of six is recommended. Several turns of a smaller diameter cable will result in a longer lasting sling than one larger diameter cable. When making a sling, avoid using cheap cable clamps. Check the clamps daily.

#### **IV-2. Installing the Clamp Attachment**

Several types of clamps are used on APE vibros to fit many different types of piles. A step by step installation procedure is provided as follows:

- 1.) Clean all drilled and tapped threads on the bottom surface of the gearbox. Use a 1 1/2"UNC tap to clean any rusted threads and blow out any remaining fragments with compressed air. If there is a cutting torch on the jobsite then use the oxygen setting to blast the threads clean. Hold a rag over the tapped hole to prevent flying dirt from blasting into your eyes.
- 2.) Clean the machined bottom surface of the gearbox and prepare to mount the clamp. If the clamp bolts should ever break, check the machined surface with a straight edge to make sure it is true and flat.
- 3.) Clean the machined surface of clamp. Check the entire surface for damage. Make sure the surface is flat and void of all dirt.
- 4.) Start by getting the center bolt in first and work outwards. Do not tighten bolts until you have all of the bolts started.
- 5.) Tighten bolts using a six-foot pipe. If you do not have a pipe then use a sledge hammer.
- 6.) Go around all bolts at least three times making sure they are tight.
- 7.) After vibrating the first pile, check the bolts again.
- 8.) If one bolt breaks, replace them all since they may be weak or cracked.
- 9.) Never operate the vibro with missing clamp bolts.

**WARNING:** Do not use grade five bolts. All bolts should be allen head cap screw bolts. If one bolt breaks then the others are damaged and must be replaced. Never drive piles if one bolt is broken. Bolts break only because they were not tight and the crew neglected to check them. A good operator insists that every bolt is checked twice daily.



# OPERATION / MAINTENANCE MANUAL

MODEL 400 TANDEM VIBRATORY HAMMER WITH  
MODEL 1000 POWER UNITS

7032 So. 196th - Kent, WA. 98032 - (206) 872-0141 / Fax (206) 872-8710

## IV. PREPARATION AND OPERATION (Continued...)

### IV-3. Plumbing the Vibro Hoses to the Power Unit.

There are five hoses leading from the vibro that must be connected to the power unit to begin operation (Please see section III-2. Hose Identification on [page 2-3] and Figure 2-B on [page 2-5]). There are two big hoses, two little hoses and one middle sized hose. The hoses attach to the power unit by screwing the quick dis-connect couplers onto the proper couplers of the power unit. The couplers on the power unit are mated with the couplers on the vibro so there is no chance of putting them on backwards. Please take the following steps when installing the couplers:

**WARNING: TURN THE POWER UNIT OFF BEFORE INSTALLING COUPLERS**

- 1.) Turn the power unit OFF.
- 2.) Clean all couplers with a can of ether if available. A clean dry cloth will also work but will require extreme care. Fittings must be spotless clean.
- 3.) Install couplers by screwing them onto their respective counterparts. Try to avoid cross-threading and maintain a straight line. Jerk the hose back and forth while turning coupler to aid installation effort. **Push hard to get the big coupler threads started.**
- 4.) Make sure fittings are tight. If they are properly cleaned they should run up tight with just a firm hand grip. However, they should be double checked with a chain wrench.
- 5.) Avoid over-tightening.
- 6.) If near salt water, spray with a light oil to prevent oxidation.
- 7.) Position the Power Unit so that vibrator has enough hose to reach the work. Avoid pulling too hard on hoses. Most hose failures are caused by pulling hoses off couplers.

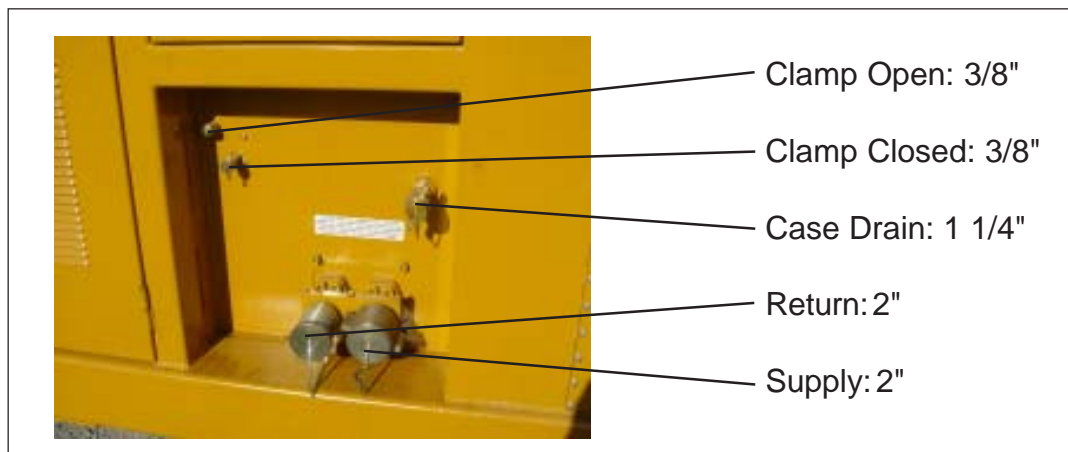

**Figure 4-A. Power Unit Coupler Layout**

# **OPERATION / MAINTENANCE MANUAL**

**MODEL 400 TANDEM VIBRATORY HAMMER WITH  
MODEL 1000 POWER UNITS**

7032 So. 196th - Kent, WA. 98032 - (253) 872-0141 / Fax (253) 872-8710

## **IV. PREPARATION AND OPERATION (Continued...)**

### **IV-4. Filling Vibrator Pressure Hose.**

The vibrator is shipped with the hoses filled with oil. However, if the unit has been sitting for a long period of time or if a damaged hose has been replaced with a new one, then the hoses must be filled. Hook up all the hoses to the power unit (see Section IV-3 on [page 4-2] and Figure 4-A.). Start the power unit and let it run for ten minutes before running the vibro. The hoses will fill up by themselves in ten minutes even if the vibro is not in the vibrate mode.

### **IV-5. Bleeding the Clamp Attachment Hydraulic Hoses.**

If the opening and closing of the jaws seems spongy or slow, it may be a result of air in the clamp hoses. Normally there is no need to worry about bleeding the clamp lines because the unit is shipped fully tested. However, should the vibro sit for a long period of time, if a new attachment is being installed or if a damaged clamp hose has been replaced, then the system may require bleeding to remove unwanted air in the system. To bleed the clamp system, follow the steps listed below:

- 1.) Shut Power Unit OFF.
- 2.) Make sure the clamp line quick dis-connects are coupled to the power unit.
- 3.) Start the power unit engine and run at 1500 rpm. Give the engine time to warm up.
- 4.) Loosen the clamp lines at the hydraulic cylinder by backing the fittings off just a little.
- 5.) Turn the clamp switch on the power unit control pendant to "CLOSE" and wait for oil to flow from the fittings. WATCH FOR AIR BUBBLES. When air bubbles have stopped then quickly re-tighten the fittings.
- 6.) Repeat the same procedure for "OPEN" side.
- 7.) Operate the jaws. If they are still a bit spongy then repeat bleeding steps once more.

**WARNING: DO NOT BLEED SYSTEM AT FULL ENGINE THROTTLE BECAUSE TOO MUCH OIL WILL FLOW FROM THE HOSES AND COULD CAUSE INJURY.**

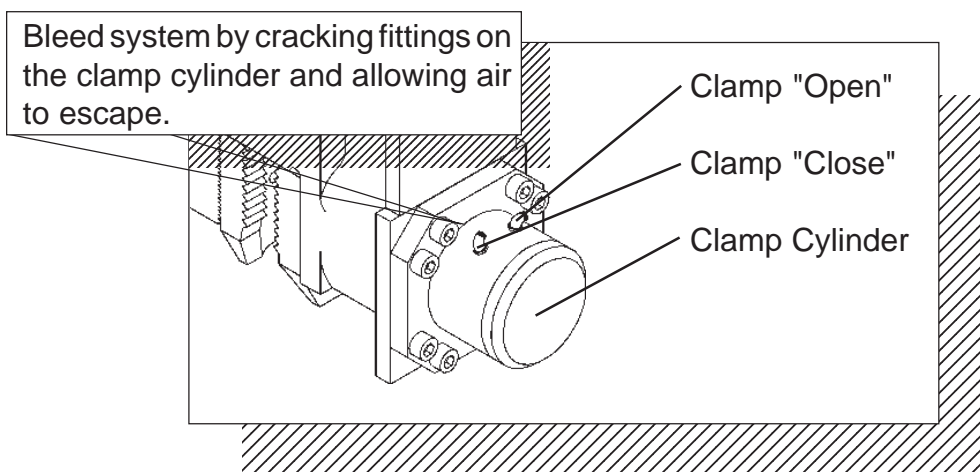

**Figure 4-B. Bleeding Clamp Attachment**



# OPERATION / MAINTENANCE MANUAL

MODEL 400 TANDEM VIBRATORY HAMMER WITH  
MODEL 1000 POWER UNITS

7032 So. 196th - Kent, WA. 98032 - (206) 872-0141 / Fax (206) 872-8710

## IV. PREPARATION AND OPERATION (Continued...)

### IV-6. Precautions and Rules for Operation.

The following is a list of precautions, suggestions and rules that are intended to help promote the safe and productive use of the APE Model 400 Vibratory Hammer.

- 1.) Follow Daily Maintenance Required Prior to Operation, [Section V-1.] [page 5-1].
- 2.) Read and follow the Safety Precautions, [page iii].
- 3.) Follow the start-up procedures listed in the manual for the power unit being used.
- 4.) **Clamp all eight clamps to concrete caisson.**
- 5.) **Hold up slightly on vibro, do not drive, do not pull.**
- 6.) **Allow vibros to come up to speed before driving- takes a few seconds.**
- 7.) **Watch clamps closely. Stop if you see anything wrong.**
- 8.) **On concrete piles start at 1500 rpm on engines.**

### IV-7. Relief Valve Setting Prior to Operation

The Relief Valve and Pressure Switches are set by the factory. They will need to be re-set if the pressure switch is replaced. **(Please see section VII for information on Controls.)**

1. Do not hook up quick disconnects. Start and warm engine . Bring to full rpm.
2. Check Clamp relief valve setting. On the Control Panel, turn the clamp switch to "OPEN" and hold it there while you read the CLAMP OPEN GAUGE on the panel. It should read 4500 PSI. If it is not coming up to pressure, then set the relief valve (FACTORY AUTHORIZED PERSONNEL ONLY), by loosening the lock nut and turning the knob in slowly until the proper pressure is reached. Turn in (CW) to increase pressure, and out (CCW) to decrease pressure. Lock the locknut and recheck the pressure to make sure that the setting did not move during tightening the lock nut. When the clamp switch is turned to "OPEN" and held, a small light on the solenoid is illuminated, showing that there is power to the solenoid. Otherwise, the light on the solenoid should be off.

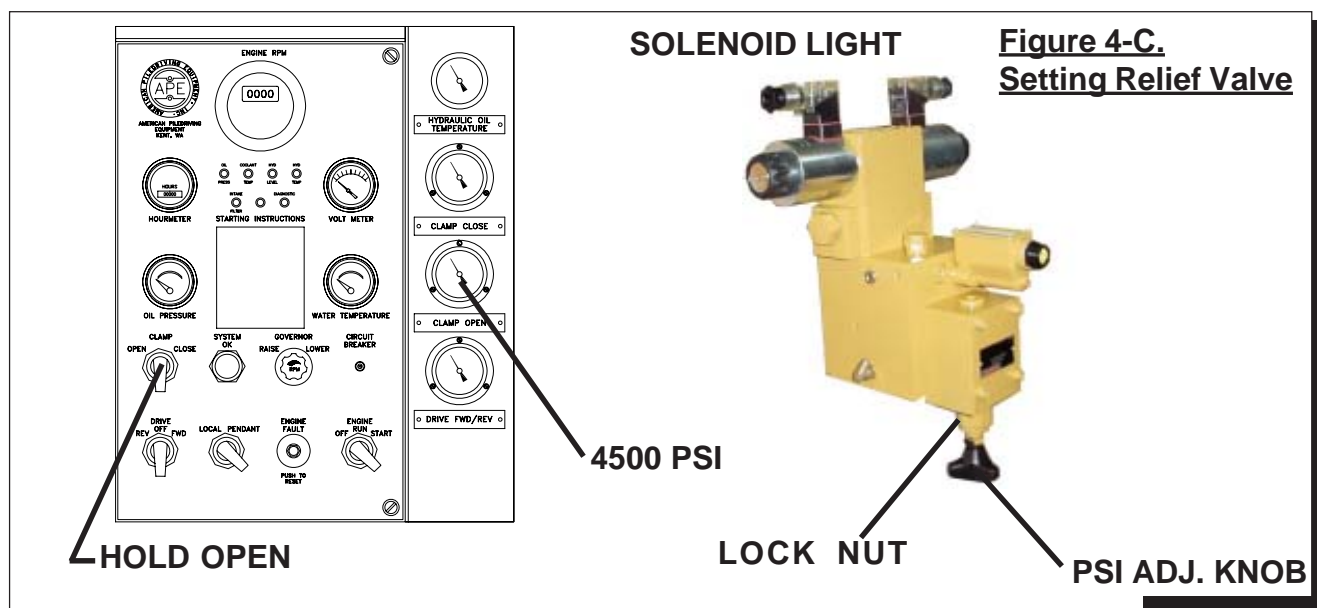

# OPERATION / MAINTENANCE MANUAL

## MODEL 400 TANDEM VIBRATORY HAMMER WITH MODEL 1000 POWER UNITS

7032 So. 196th - Kent, WA. 98032 - (253) 872-0141 / Fax (253) 872-8710

### IV. PREPARATION AND OPERATION (Continued...)

3. Check the clamp pressure switch setting. Turn the clamp to "CLOSE". If there is proper clamp pressure the CLAMP CLOSE GAUGE should read 4500 PSI to 4950 PSI, and the GREEN LIGHT comes on (see figure 4-D.)

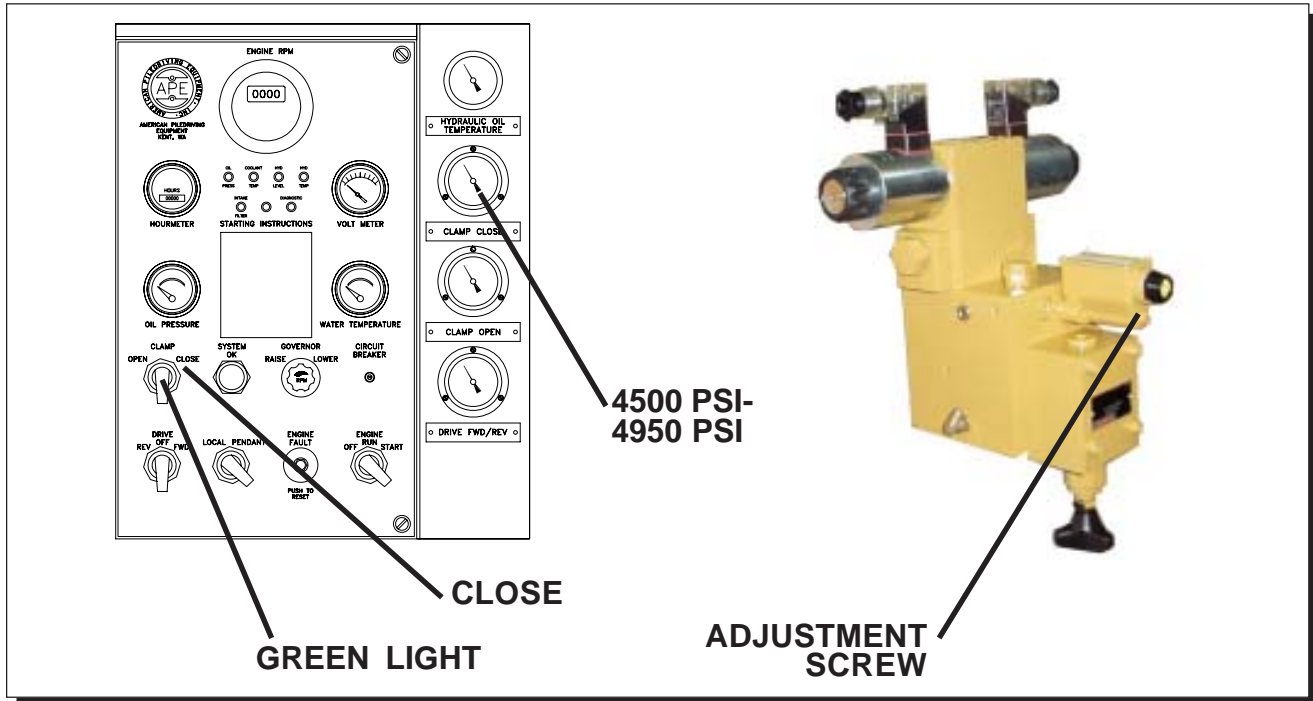

**Figure 4-D. Checking Clamp Pressure Switch Setting**

4. Adjust the clamp pressure switch setting. (If necessary). To set the pressure switch, turn the adjustment screw out using a screwdriver. (Turn it out a few turns counter-clockwise.) Turn clamp switch to "OPEN" for a second. Make sure the CLAMP OPEN GAUGE reads 4500 PSI. If it does not, then go back to the Step 2 and set the clamp relief valve first.

With clamp relief set at 4500 PSI, turn the clamp switch to "CLOSE". Green light should be on and clamp pressure should be very low or not reading at all.

Turn Adjustment Screw in (CW) until the green light goes off. Then, turn adjustment screw out (CCW) until green light comes on. (About 1/4 to 1/2 turn.) The CLAMP CLOSE GAUGE should read 4500 to 4950 PSI.

To check, turn clamp switch to "OPEN". The green light should be on.

Repeat procedure if necessary.





# OPERATION / MAINTENANCE MANUAL

MODEL 400 TANDEM VIBRATORY HAMMER WITH  
MODEL 1000 POWER UNITS

7032 So. 196th - Kent, WA. 98032 - (206) 872-0141 / Fax (206) 872-8710

## IV. PREPARATION AND OPERATION (Continued...)

### IIV-9. Operation of the Remote Control Pendant.

1. All functions of the vibro can be controlled by the hand held pendant. It is the choice of the crew as to where best to locate the pendant. Some prefer to give it to the crane operator so he can control all functions. Others prefer to give it to one of the ground crew so that he can position himself close to the work at hand. A 50 foot cord is provided as standard equipment. If this is not long enough, additional 50 foot sections can be added. Should the pendant become damaged, all functions can be manually operated. See Section VII-3, Page 7-8 in this manual for more details on operation. See Section VII-3A, Page 7-9 of this manual for wiring diagram and pendant components.

### IV-10. Normal steps to operate vibrator:

1. Position vibro on pile.
2. Turn clamp switch to Close and wait for light to come on pendant.
3. Turn to Forward to begin vibrating pile.
4. To drive, lower crane line as vibro vibrates pile.
5. To extract, pull up on vibro while vibrating.
6. See "Precautions and Rules for Operation" in this manual for more detailed operations on driving and extracting piles.
7. To stop the vibro turn the Forward switch to off.
8. To release clamp, press clamp switch clamp light will turn off.

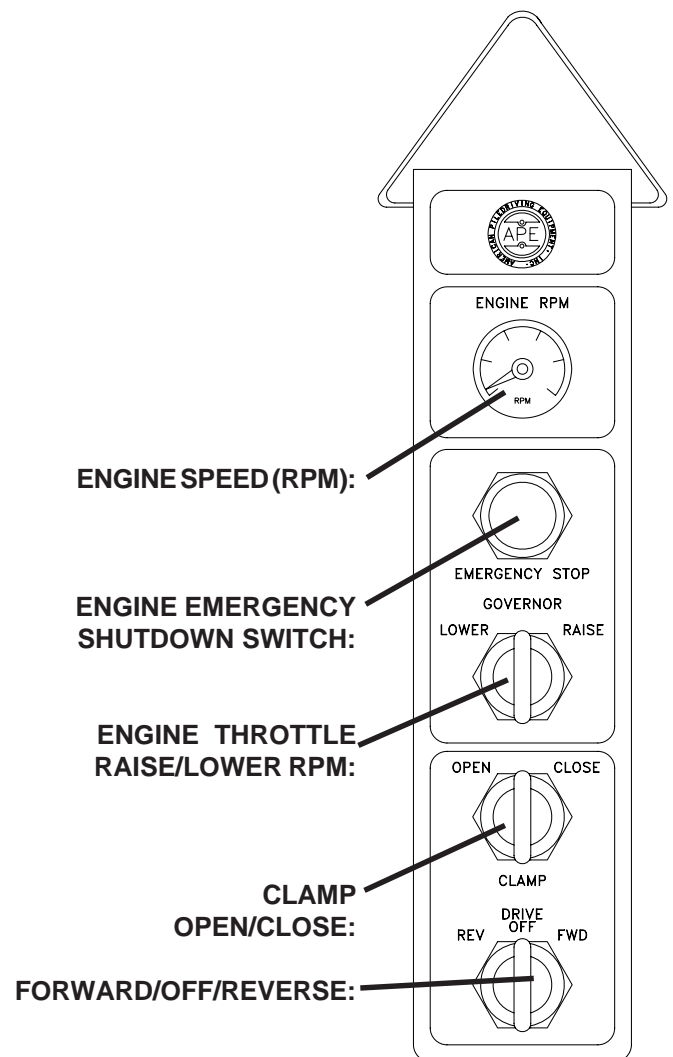

# **OPERATION / MAINTENANCE MANUAL**

**MODEL 400 TANDEM VIBRATORY HAMMER WITH  
MODEL 1000 POWER UNITS**

7032 So. 196th - Kent, WA. 98032 - (253) 872-0141 / Fax (253) 872-8710

## **V. MAINTENANCE**

### **V-1. Daily Maintenance Required Prior to Operation.**

- 1.) Visually inspect the entire vibro for loose nuts or bolts. Put a wrench on the clamp bolts and check them for tightness.
- 2.) Grease the Jaw Plunger on the clamp housing.
- 3.) Check the oil level in the vibrator. Hang vibro from crane and look at sight gauge. Make sure the oil is half way up gauge. If you cannot read it then you can't run the vibro. Remove the gauge and clean it by spraying a shot of starting fluid at it. **YOU MUST KNOW THE LEVEL!**

**IF THE OIL LOOKS BLACK OR MILKY THEN DRAIN THE GEARCASE AND ADD NEW HYDRAULIC OIL.**

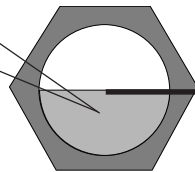

**Oil Level  
Mobil SHc 629**

**Sight Gauge**

- 4.) If the oil is milky or black then change it. **Change the oil every 75 hours regardless.**
- 5.) Check the fluid level in the power unit hydraulic tank.
- 6.) Look at all the hoses. Check for cuts or other damage that might cause an oil leak.
- 7.) Check the rubbers in the suppressor housing. Look for cracks.
- 8.) Perform all start up checks as per the "start-up procedures" in the Power Unit manual.

### **V-2. Checklist After Power Unit Engine Has Started**

- 1.) Check all hydraulic hoses for leaks. Make sure they hang free with no kinks.
- 2.) Check inside the Power Unit. Look at all hoses and valves, check for leaks.
- 3.) Check filter indicator with engine running at full rpm. Replace if necessary.
- 4.) Check wire rope sling and make sure it is in excellent condition.
- 5.) Check jaws for wear. Replace if necessary.
- 6.) Close jaws, make sure clamp light comes on.



# **OPERATION / MAINTENANCE MANUAL**

**MODEL 400 TANDEM VIBRATORY HAMMER WITH  
MODEL 1000 POWER UNITS**

7032 So. 196th - Kent, WA. 98032 - (206) 872-0141 / Fax (206) 872-8710

## **V. MAINTENANCE (Continued...)**

### **V-3. Maintenance and Adjustments. (75 Hours)**

Change the oil in vibrator gearbox. Remove the drain plug from bottom of gearbox and drain the oil into a bucket. Check oil for any metal shavings. Replace oil in gearbox by adding 25 gallons of standard weight oil. Mobil Gear 629.

Clean the gearbox breathers each time the oil is changed. Replace the breathers if necessary.

### **V-4. Maintenance and Adjustments. (Eccentric Bearings)**

The Eccentric Bearings should be checked and/or replaced after every 5000 hours of diesel engine operation.

### **V-5. Maintenance and Adjustments in Severe Conditions.**

When average temperature is above (80 deg. F) or below (-1 deg. F) reduce servicing intervals to one half of those specified above.

When operating in the presence of dust or sand, reduce servicing intervals to one-third of those specified.

During stand-by or inactive periods, the servicing intervals may be reduced to one-half. The unit should be run every 30 days or less to keep internal parts lubricated.

### **V-6A. Lubrication - Vibratory Gearbox.**

The Gearbox oil should be changed weekly or when black or milky. Mobil Gear 629 or equal is the preferred oil. The gearbox requires 25 gallons of oil.

### **V-6B. Lubrication - Clamp Attachment.**

The Clamp Attachment hydraulic oil must be checked and changed on a regular basis. The Clamp Cylinder Plunger should be checked for rust and debris. Lubricate the plunger on a regular basis using the grease zert on the side of the clamp housing .



# OPERATION / MAINTENANCE MANUAL

MODEL 400 TANDEM VIBRATORY HAMMER WITH  
MODEL 1000 POWER UNITS

7032 So. 196th - Kent, WA. 98032 - (253) 872-0141 / Fax (253) 872-8710

## V. MAINTENANCE (Continued...)

### V-7A. Power Unit - Filters, Fluid Types, and Capacities. (Table 5-A.)

Refer to CAT manuals for current information on engine.

## FILTERS

LOCATION	ENGINE	FILTER TYPE	QUANTITY
Engine Oil:	CAT Engines	CAT 1 R0716	2 each
Engine Fuel:	CAT Engines	CAT 1 R0749	2 each
Fuel/Water separation	CAT	CAT 129-0373	1 each
Inner Air Filter:	CAT Engines	CAT 6I-2510	2 each
Outer Air Filter	CAT	6I-2509	2 each
Hydraulic Oil Filters:	-----	APE 543051	1 each
Oil Filter Element		APE 533033	1 each
Hand Pump Filter:	-----	Zinga Ae-25 Micron	1 each

## ENGINE OIL TYPES AND CAPACITIES

LOCATION	ENGINE	OIL TYPE	CAPACITY
Hydraulic Oil-Main:	-----	Mobil Hyd AW46	667 gallons
Hyd Oil-Reserve:	-----	Mobil AW46	105 gallons
Engine Oil:	CAT Engines	Delvac 1300 15/30	48 quarts
Engine Water:	-----	50/50 Water/Gycol	27 gallons
Fan Drive:	-----	Multi-Purpose Grease	
Governor Control:	-----	Multi-Purpose Grease	
GearBox:	-----	90W or Synthetic Model 639	

See small sight glass in center of vibro gearbox between hydraulic motors. Oil should be filled to this level. Change every six months.

**IF THE OIL LOOKS BLACK OR MILKY THEN DRAIN THE GEARCASE AND ADD NEW OIL.**

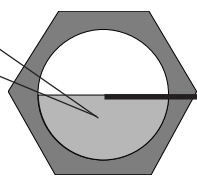

Oil Level  
Mobil SHc 629

Sight Gauge



# **OPERATION / MAINTENANCE MANUAL**

**MODEL 400 TANDEM VIBRATORY HAMMER WITH  
MODEL 1000 POWER UNITS**

7032 So. 196th - Kent, WA. 98032 - (206) 872-0141 / Fax (206) 872-8710

## **V. MAINTENANCE (Continued...)**

### **V7-B. Power Unit - Hydraulic Fluid.**

When adding or changing hydraulic fluid APE, consult your local oil supplier for recommendations on mixing hydraulic oils. Change hydraulic oil if it looks milky. This includes all hydraulic lines leading to and from the vibro. Milky oil indicates that water is in the oil.

### **V7-C. Power Unit - Draining and Filling Hydraulic Fluid Tank**

1. Remove plug located on bottom of tank
2. Refill by manually pumping with hand crank.
3. Prime both the clamp and the main pump before restarting.
4. Take extreme caution that no dirt or other unwanted particles enters the system.



# **OPERATION / MAINTENANCE MANUAL**

**MODEL 400 TANDEM VIBRATORY HAMMER WITH  
MODEL 1000 POWER UNITS**

7032 So. 196th - Kent, WA. 98032 - (253) 872-0141 / Fax (253) 872-8710

## **V. MAINTENANCE (Continued...)**

### **V-7D. Power Unit - Changing Hydraulic Return Filter Element.**

The hydraulic return filter is mounted on the hydraulic tank inside the power unit. It is mounted high on the tank so that when the filter element is removed the oil will not drain from the hydraulic tank. The filter has a manual pop-up type indicator to tell when the filter is dirty. The pop-up indicator turns red when it is dirty.

### **V-7E. Power Unit - Steps to Remove the Element.**

1. Shut down power unit by turning off the diesel engine.
2. Place warning tag on control panel so that no one mistakenly starts the unit while filters are being changed.
3. Clean area around filter so that when it is removed there is no chance of introducing dirt into the hydraulic system.
4. Using a filter wrench, turn the filter counter clockwise and spin the filter off the filter housing.
5. Install new clean filter making sure the o-ring is in place.
6. Depress filter indicator to re-set to "clean position".



# **OPERATION / MAINTENANCE MANUAL**

**MODEL 400 TANDEM VIBRATORY HAMMER WITH  
MODEL 1000 POWER UNITS**

7032 So. 196th - Kent, WA. 98032 - (206) 872-0141 / Fax (206) 872-8710

## **V. MAINTENANCE (Continued...)**

### **V-8. Hydraulic Motor - Installation and Start-Up. - Figure 5A.**

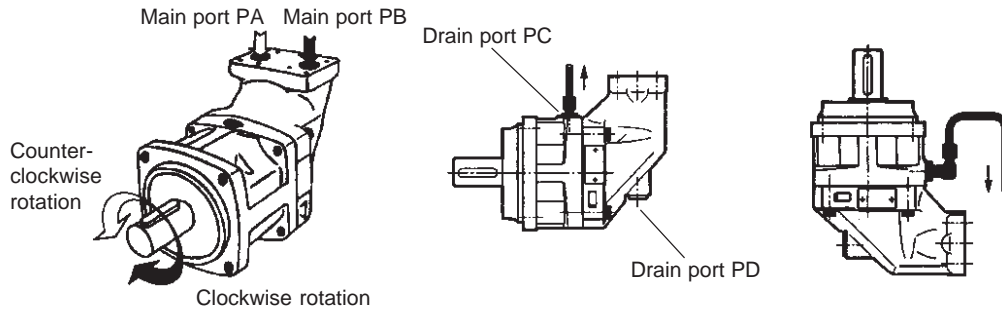

Make sure you fill the hydraulic motor case full of oil prior to running the vibro. Running the motor with a dry case will result in motor failure due to heat and cavitation.

# OPERATION / MAINTENANCE MANUAL

MODEL 400 TANDEM VIBRATORY HAMMER WITH  
MODEL 1000 POWER UNITS

7032 So. 196th - Kent, WA. 98032 - (253) 872-0141 / Fax (253) 872-8710

## V. MAINTENANCE (Continued...)

### V-9. Hydraulic Motor Coupling Assembly.

The APE Hydraulic Motor Coupling Assembly allows the hydraulic fluid to flow between the rifle bored top plate of the vibro gearbox and the hydraulic motors. The following steps should be followed when removing and installing the hydraulic motors or if disassembly is required for maintenance of the coupling assembly:

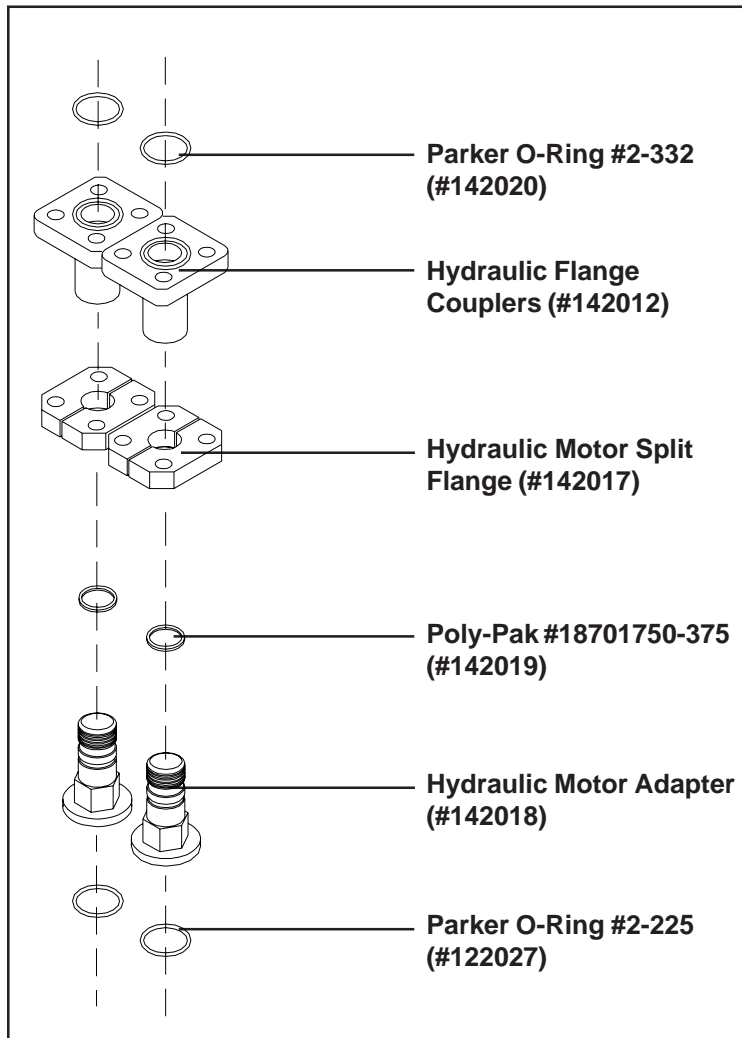

#### Coupling Removal and Re-assembly:

1. Remove the bolts holding the "Split Flange" to top of the motor.
2. Loosen the 4 bolts which connect the "Hydraulic Flange Couplers" to the bottom of the gearbox top plate.
3. Screw the "Hydraulic Flange Couplers" and the "Hydraulic Motor Adapters" together (This will decrease the overall size of the assembly and allow easier removal of the components).
4. Watch for oil flowing out from the openings on the under side of the top plate. Insert a clean rag into the openings to block the oil flow and to prevent debris from entering the opening and contaminating the hydraulic oil.
5. Reverse the procedure for re-assembly. At assembly, make sure the hydraulic motor is parallel to the top plate by verifying both sides with a tape measure. If necessary, loosen the 4 bolts holding the motor to the gearbox face and shift the motor until the top plate and motor machined face are parallel.

**Figure 5-B. Hydraulic Motor Coupling Assembly.**



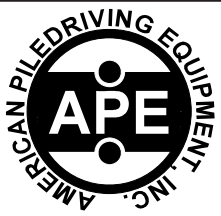

# OPERATION / MAINTENANCE MANUAL

MODEL 400 TANDEM VIBRATORY HAMMER WITH  
MODEL 1000 POWER UNIT

7032 So. 196th - Kent, WA. 98032 - (253) 872-0141 / Fax (253) 872-8710

## VI. TROUBLE-SHOOTING

The following table lists some possible problems, causes and solutions. If a serious problem should occur, contact the factory for additional service information.

**Table 6-A. Vibro Trouble-Shooting Index**

ITEM	PROBLEM	ITEM	PROBLEM
1.	Oil Blowing Out Between Gear box and Hydraulic Motor.	6.	Vibrator Won't Start When Start Button is Engaged.
2.	Vibro Gearbox is Too Hot.	7.	Clamp Won't Open When Clamp Open Switch is Engaged.
3.	Excess Oil in the Gearbox.	8.	Vibro Won't Come Up to Normal Operating Speed.
4.	Oil Blowing Out From Pop-Off Valve.	9.	Vibro Won't Stop When Stop Button is Engaged.
5.	Opening and Closing Clamp Jaws Seems Spongy or Slow.		

### Possible Cause

### Remedy

#### 1. Oil Blowing Out Between Gearbox and Hydraulic Motor.

The breather may be plugged or damaged.

Remove the breather and clean it. If the breather is damaged replace it.

O-rings may not be sealing properly

Check the o-rings between the gearbox top plate and the motor. Clean the seal areas and replace the o-rings if needed.

#### 2. Vibro Gearbox is Too Hot.

Oil level may be too high.

Make sure the gearbox is level. Remove the oil over fill plug (located on the gearbox next to the sight gage). If oil flows out, the oil level is too high and must be lowered.

Oil may be too dirty.

Look at oil in the sight gage. If the oil is black or milky it must be replaced. If you are still not sure, remove the case drain plug and check the oil.

#### 3. Excess Oil in the Gearbox.

The seal between the gearbox and the hydraulic motor may be bad and is allowing oil to flow directly into the gearbox.

Remove the motor from the face of the gearbox. Check and clean the seal area, replace the seal if it looks bad.

#### 4. Oil Blowing out Pop-Off Valve.

Blocked flow in case drain line.

Check case drain line to see if it is pinched.

Check case drain line for proper connection tightness.

Valve may be bad.

Remove and check the valve. Replace the valve if needed.

One or both motors may be damaged.

Remove the motors and have them checked for damage. Replace if needed.



# **OPERATION / MAINTENANCE MANUAL**

**MODEL 400 TANDEM VIBRATORY HAMMER WITH  
MODEL 1000 POWER UNIT**

7032 So. 196th - Kent, WA. 98032 - (253) 872-0141 / Fax (253) 872-8710

## **VI. TROUBLE-SHOOTING (Continued...)**

### **Possible Cause**

### **Remedy**

#### **5. Opening and Closing Clamp Jaws Seems Spongy or Slow.**

The plunger shaft may not be properly lubricated or may need cleaning.

Remove the movable jaw from the clamp. Inspect the plunger shaft and check for lubrication or debris build up. Clean the shaft if needed and then lubricate using the grease zert on the clamp body.

The clamp hoses may have air in them and may need bleeding.

Follow the procedures listed in this manual (page 4-3, Section IV-5.) for bleeding the clamp attachment hydraulic hoses.

#### **6. Vibrator Won't Start When Start Button is Engaged.**

Diesel engine is not running.

Start diesel engine.

Start relay contacts may not be closing.

Press and hold the Start Button on the pendant. If vibro starts, replace Start Relay.

Hoses may be connected improperly.

Check hoses and make connection corrections if required.

One or both hydraulic motors may not be operating properly.

Remove one hydraulic motor from the vibro. Leave the hoses connected. Run the power unit engine at approx. 1200 rpm. and press the start button. If motor runs, re-attach it to the vibro and perform the same test with the other motor. If one of the motors does not run, it must be replaced.

Vibro gearbox may be frozen up.

If motors are working fine and the drive pressure appears normal, then the vibro gearbox may be frozen and in need of repair.

Drive pressure is too low.

Manually close start valve at the drive manifold. If vibro will not start, replace the start valve. If vibro still will not start, replace the drive pump.

#### **7. Clamp Won't Open When Clamp Open Switch is Engaged.**

Vibrator is running.

The clamp won't open while the vibro is in operation. To open the clamp, stop the vibro.

Diesel engine may not be running.

Start the power unit engine and allow clamp pressure to build.

There may be an electrical failure.

Check for the following:  
- Defective clamp switch.  
- Broken or loose wire in the pendant or pendant cable.  
- Defective OPEN solenoid.  
- Broken or loose wire between main power switch and START relay.  
- Defective or sticking clamp timing delay relay.  
- Broken or loose wire between main power switch and amphenol connector.

The clamp pump may be defective.

Check clamp pump for slipping belts and tighten if required. If clamp won't open, replace clamp check valves. If clamp still won't open, replace the clamp pump.



# **OPERATION / MAINTENANCE MANUAL**

**MODEL 400 TANDEM VIBRATORY HAMMER WITH  
MODEL 1000 POWER UNIT**

7032 So. 196th - Kent, WA. 98032 - (253) 872-0141 / Fax (253) 872-8710

## **VI. TROUBLE-SHOOTING (Continued...)**

### **Possible Cause**

### **Remedy**

#### **8. Vibro Won't Come Up to Normal Operating Speed.**

Defective hydraulic motor or drive pump.

If vibration frequency has been verified lower than normal, Replace the hydraulic motors one at a time to see if performance improves. If vibro still operates below normal speed, replace drive motor pump.

#### **9. Vibro Won't Stop When Stop Button is Engaged.**

There may be an electrical failure.

Check for the following:

- Defective STOP button.
- Broken or loose wire in the pendant or pendant cable.
- Defective START relay.
- Defective motor START valve.



# **OPERATION / MAINTENANCE MANUAL**

**MODEL 400 TANDEM VIBRATORY HAMMER WITH  
MODEL 1000 POWER UNIT**

**7032 So. 196th - Kent, WA. 98032 - (253) 872-0141 / Fax (253) 872-8710**

**THIS PAGE INTENTIONALLY BLANK**

# OPERATION / MAINTENANCE MANUAL

MODEL 400 TANDEM VIBRATORY HAMMER WITH  
MODEL 1000 POWER UNIT

7032 So. 196th - Kent, WA. 98032 - (253) 872-0141 / Fax (253) 872-8710

## VII. MODEL 1000 POWER UNIT

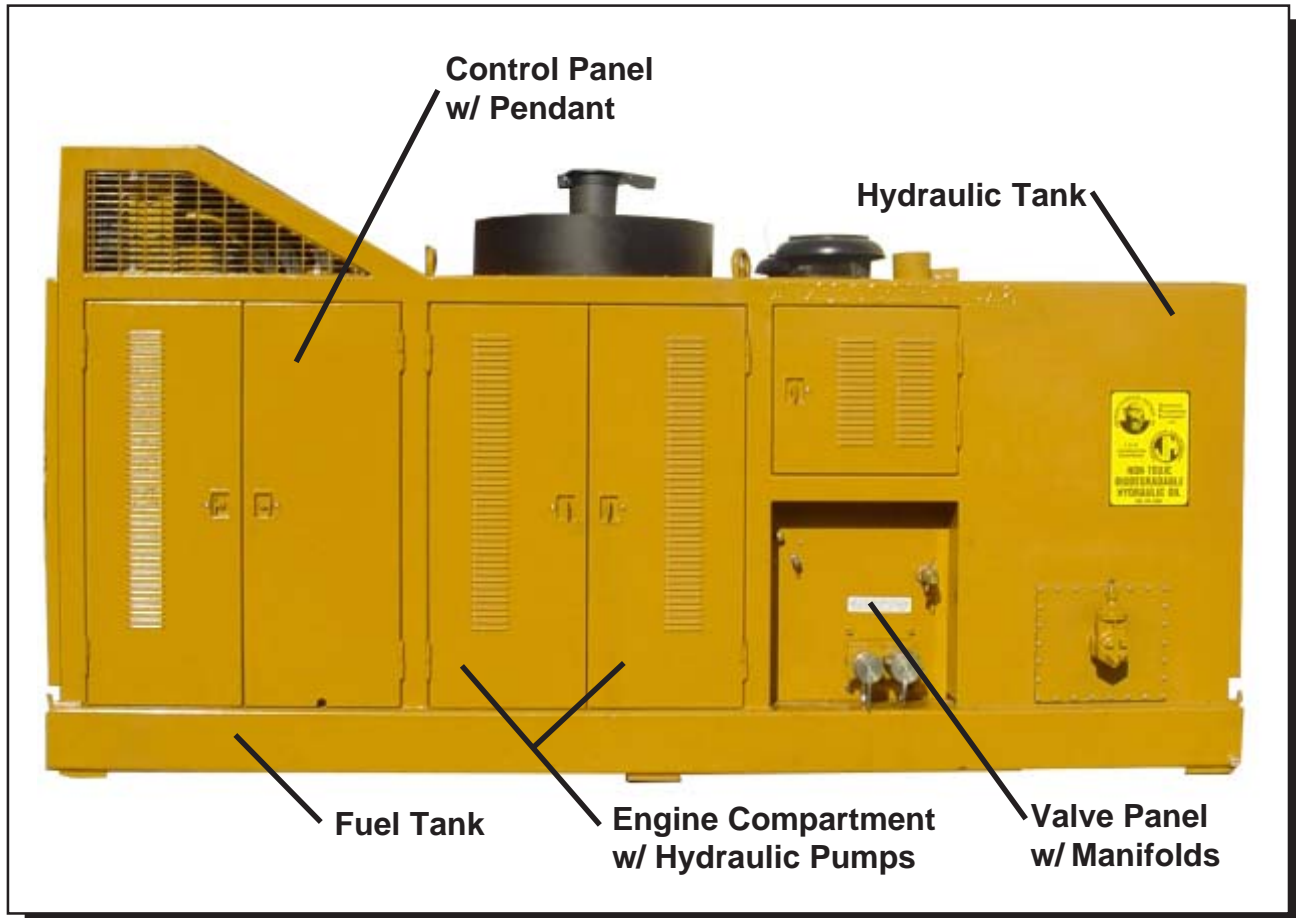

**Figure 7-A. APE 1000 Power Unit - Left Side View**

### **VII-1. Power Unit Skid**

For a general breakdown of the power unit skid, see section II-3.

### **VII-2. Power Unit Systems - General Description**

The APE model 1000 power unit provides hydraulic pressure and flow to drive APE hydraulic equipment. In its standard configuration it is equipped for vibratory hammers. It can be equipped to provide power for hydraulic impact hammers and earth augers as well.

**Fuel Tank** - The fuel tank consists of the tubular steel members comprising the base of the skid. The fuel capacity is 167 gallons (633 liters), diesel fuel only. The filler cap is located on the right hand side. The fuel tank is plumbed to provide fuel flow to the engine.



# **OPERATION / MAINTENANCE MANUAL**

## **MODEL 400 TANDEM VIBRATORY HAMMER WITH MODEL 1000 POWER UNIT**

7032 So. 196th - Kent, WA. 98032 - (253) 872-0141 / Fax (253) 872-8710

### **VII. MODEL 1000 POWER UNIT (Continued...).**

#### **VII-2. Power Unit Systems - General Description (Continued...)**

**A. Engine** - The engine is a 1000 HP (745 kW) Caterpillar 3412E diesel engine. It provides rotational power to drive the hydraulic pumps. (See CAT manual for detailed description.)

**B. Valve Panel** - The valve panel is located on the left side of the power unit, near the rear. It contains "quick disconnect couplers" to attach the hoses to the hydraulic machinery.

**C. Hydraulic Tank** - The hydraulic tank is located on the rear of the unit. It consists of a Main tank (lower) and a Reserve tank (upper). The capacity of the Main tank is 677 gallons (2563 liters). The capacity of the reserve tank is 105 gallons (397 liters). The hydraulic tank is filled using a hand pump, provided on the right hand side of the power unit. There is a manually operated transfer valve (located on the tank wall) that allows the fluid from the reserve tank to be transferred to the main tank.

Sight glasses are provided to allow the fluid levels to be monitored. They are located inside the power unit skid on the right hand side, on the hydraulic tank wall. An electric float switch will shut down the engine if the fluid level falls unacceptably low.

The hydraulic tank is plumbed to send hydraulic fluid to the pumps, and then to the Hydraulic Control Manifolds, and from there to the hydraulic machinery.

**D. Hydraulic Pumps & Pump Drive** - There are five hydraulic pumps. Three of these pumps (large) are "Drive Pumps" located at the rear of the engine, providing flow to the Drive Manifold. One of these pumps (large) is for hydraulic re-circulation. One of the pumps (small) is a "Clamp Pump", located at the rear side of the engine, providing flow to the Clamp Manifold. **Pump Drive** - The pump drive is located at the rear of the engine. It couples the engine to the "Drive Pumps".

**E. Hydraulic Circuit & Manifolds** - There are two hydraulic manifolds. The (small) Clamp Manifold (Fig. 7-) is located on the left hand side of the power unit, near the rear of the engine. The (large) Drive Manifold (Fig 7-) is located at the rear, left hand side of the power unit, near the coupler panel. The manifolds respond to operator commands at the control panel (or the pendant), allowing the hydraulic oil to flow to the hydraulic machinery.

#### **F. Component Breakdown & Full Schematic**

**G. Control Panel** - The control panel (Fig. 7-D) is located on the left side of the power unit, inside a door. It allows the operator to control and monitor the engine and the hydraulic machinery.

**H. Pendant** - The control pendant allows the operator to control the hydraulic machinery remotely, via a 50 ft (15m) power cord.

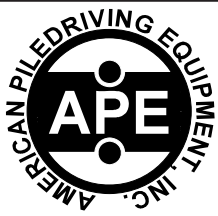

# OPERATION / MAINTENANCE MANUAL

MODEL 400 TANDEM VIBRATORY HAMMER WITH  
MODEL 1000 POWER UNIT

7032 So. 196th - Kent, WA. 98032 - (253) 872-0141 / Fax (253) 872-8710

## VII. MODEL 1000 POWER UNIT (Continued...)

### VII-2A. Engine Systems - See CAT Manuals

#### Diesel Engine.

The HYDRAULIC POWER UNIT is powered by a 4 stroke compression ignition diesel engine. Two 12 volt (4D) batteries provide 24 volts for starting the engine and running the electrical controls.

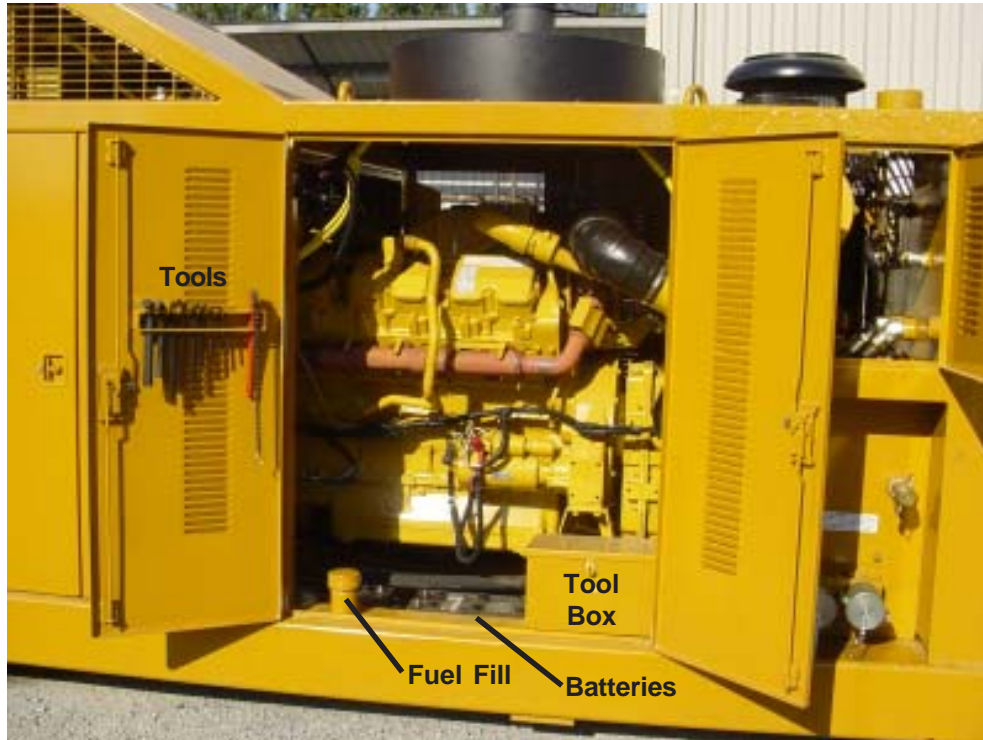

Alt. Breaker      Circuit Breaker

Starter Solenoid      Starter

**Figure 7-B. Engine**

# OPERATION / MAINTENANCE MANUAL

MODEL 400 TANDEM VIBRATORY HAMMER WITH  
MODEL 1000 POWER UNIT

7032 So. 196th - Kent, WA. 98032 - (253) 872-0141 / Fax (253) 872-8710

## VII. MODEL 1000 POWER UNIT (Continued...)

### VII-2B. Valve Panel (Front & Rear)

Figure 7-C. Valve Panel

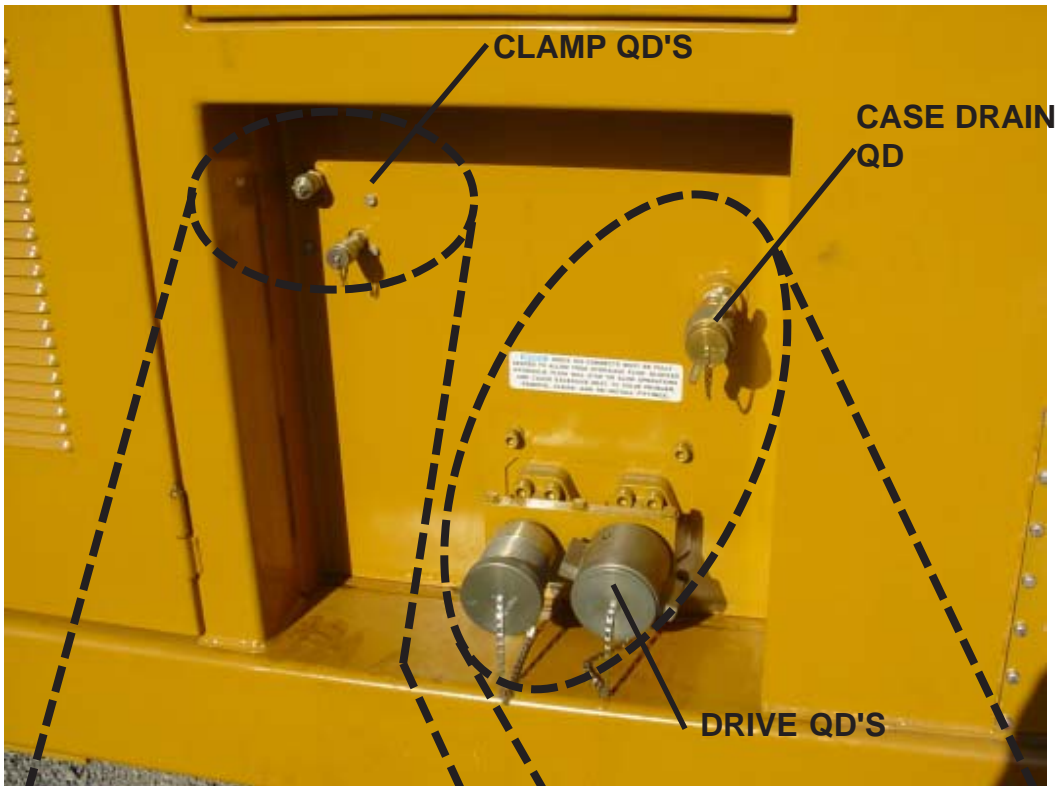
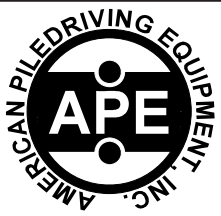

Figure 7-D. Clamp Manifold Installed



Figure 7-E. Drive Manifold Installed





# OPERATION / MAINTENANCE MANUAL

## MODEL 400 TANDEM VIBRATORY HAMMER WITH MODEL 1000 POWER UNIT

7032 So. 196th - Kent, WA. 98032 - (253) 872-0141 / Fax (253) 872-8710

### VII. MODEL 1000 POWER UNIT (Continued...)

#### VII-2C. Hydraulic Tank

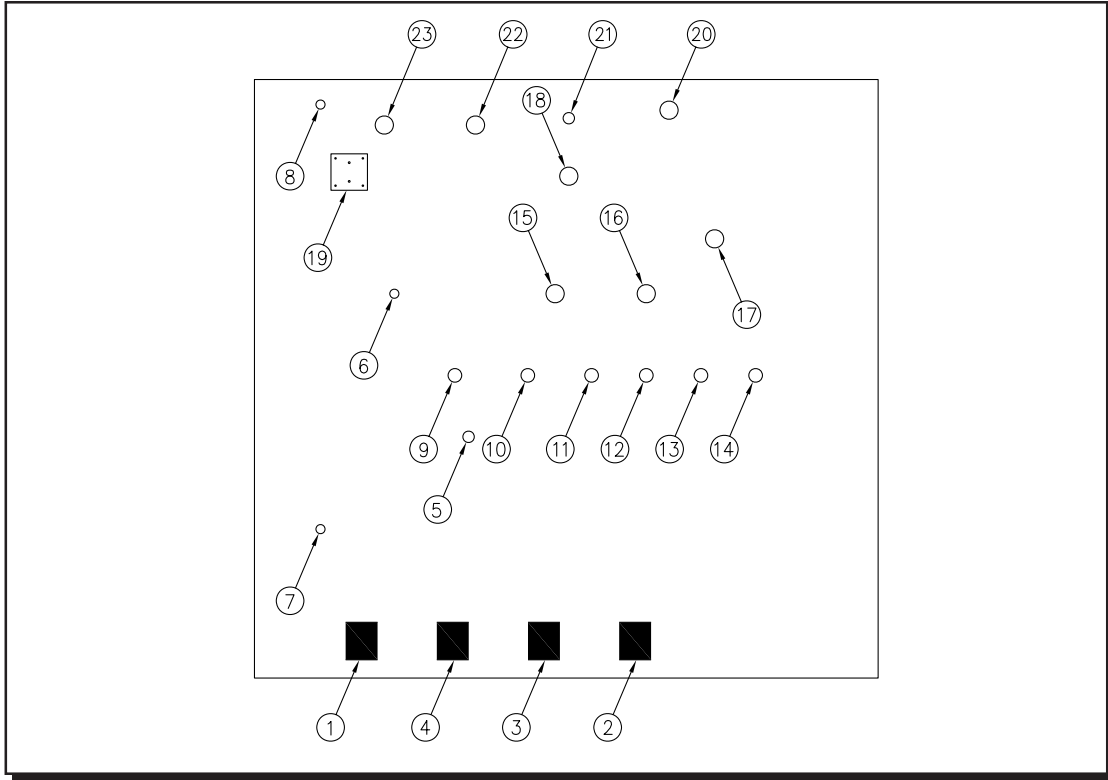

**Figure 7-F. Hydraulic Tank Fittings - View to Rear**

1	Suction header & shutoff valve to drive pump 1
2	Suction header & shutoff valve to drive pump 2
3	Suction header & shutoff valve to drive pump 3
4	Suction header & shutoff valve to re-circulation pump
5	Clamp pump suction & shutoff valve
6	Hydraulic oil temperature gauge fitting
7	Sight gauge fitting - lower
8	Sight gauge fitting - upper
9	Spare
10	Clamp pump case drain
11	Vibro case drain
12	Spare
13	Drive manifold drain
14	Clamp manifold return
15	Drive manifold return
16	Drive manifold return
17	Tank transfer fitting - lower
18	Tank transfer fitting - upper
19	Hydraulic level gauge mount
20	Filler port
21	Breather fitting
22	Return filter fitting
23	Spare

**Table 7-A. Hydraulic Tank Fittings**

# OPERATION / MAINTENANCE MANUAL

MODEL 400 TANDEM VIBRATORY HAMMER WITH  
MODEL 1000 POWER UNIT

7032 So. 196th - Kent, WA. 98032 - (253) 872-0141 / Fax (253) 872-8710

## VII. MODEL 1000 POWER UNIT (Continued...)

### VII-2D. Pumps & Pump Drive

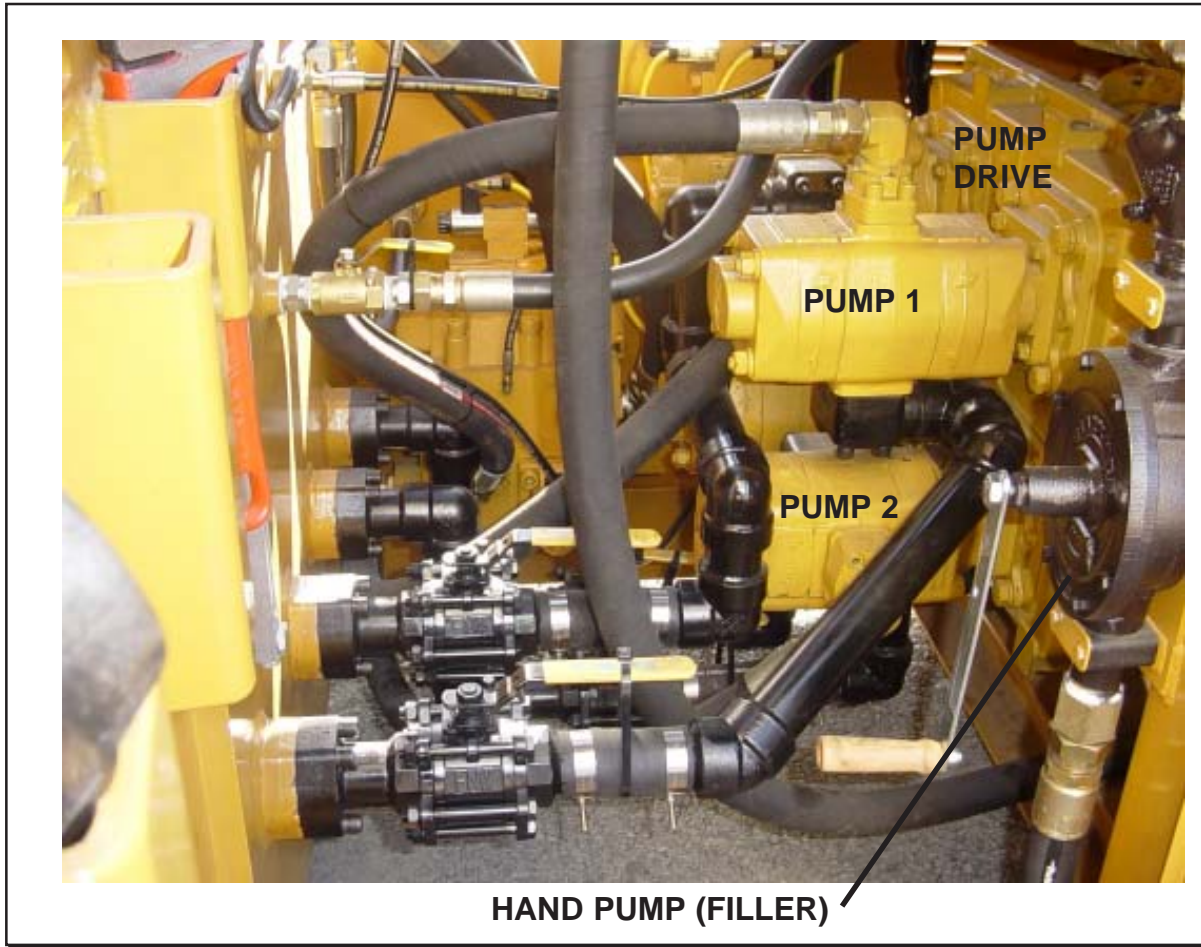

**Figure 7-G. Suction Headers / Pumps**

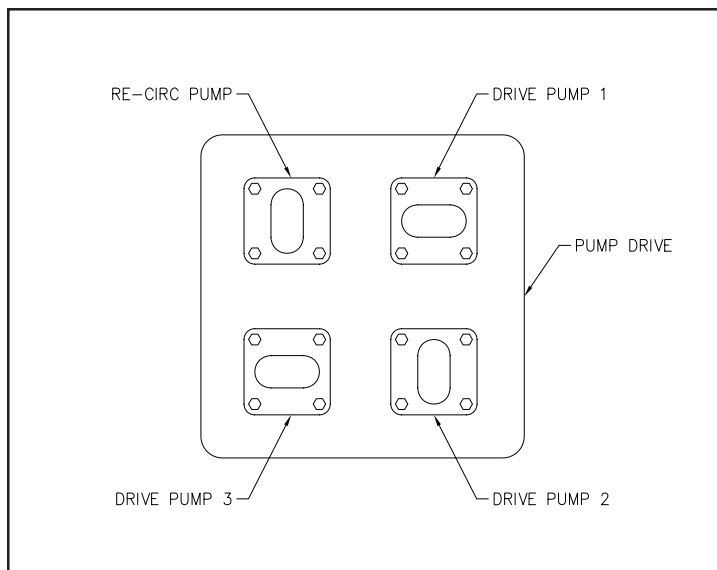

**Figure 7-H. Drive Pumps - View to Front**



# **OPERATION / MAINTENANCE MANUAL**

**MODEL 400 TANDEM VIBRATORY HAMMER WITH  
MODEL 1000 POWER UNIT**

7032 So. 196th - Kent, WA. 98032 - (253) 872-0141 / Fax (253) 872-8710

## **VII. MODEL 1000 POWER UNIT (Continued...)**

### **VII-2D. Pumps & Pump Drive (Continued...)**

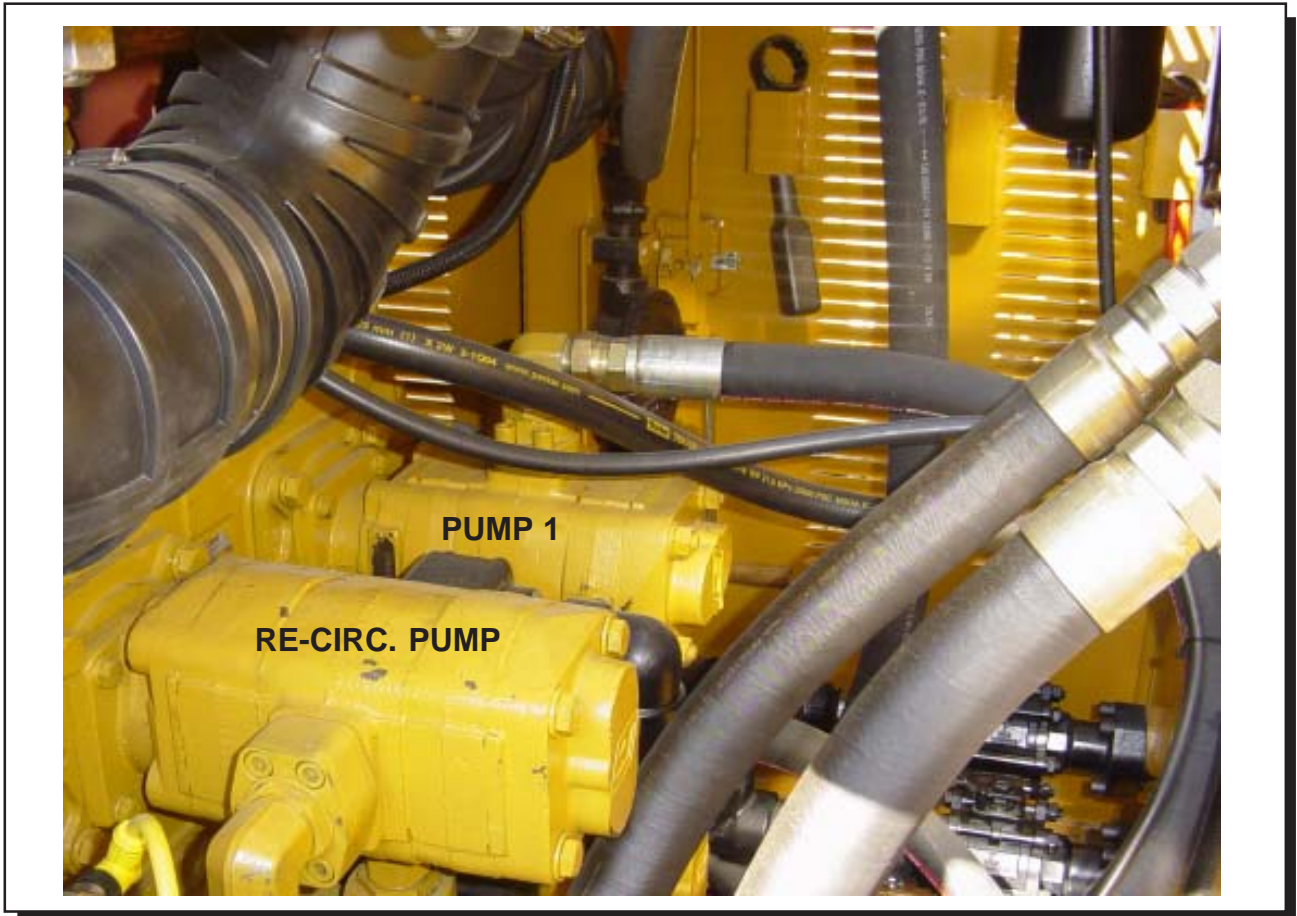

**Figure 7-I. Re-Circ & Drive Pumps**



# OPERATION / MAINTENANCE MANUAL

## MODEL 400 TANDEM VIBRATORY HAMMER WITH MODEL 1000 POWER UNIT

7032 So. 196th - Kent, WA. 98032 - (253) 872-0141 / Fax (253) 872-8710

### VII. MODEL 1000 POWER UNIT (Continued...)

#### VII-2E. Hydraulic Circuits & Manifolds

The model APE 1000 hydraulic power unit consists of fixed displacement gear pumps rated at 5000-psi maximum pressure. The hydraulic circuit is designed to operate the APE King Kong Vibro in the forward and reverse mode. A 120-gpm cooling pump provides a separate cooling loop flow from the oil tank through the cooler and return filter. A fixed displacement piston pump is used for the vibro clamp circuit with a flow of 10-gpm and maximum pressure of 5000-psi. All pumps are rated at engine speed of 2100-rpm.

#### DRIVE CIRCUIT

The drive circuit has three double pumps, used for driving the vibro. The three drive pumps combined provide up to 273 gpm. The oil is drawn from the oil tank through the manual shut-off valves to the intake port of the pumps. **Note:** There are no strainer or suction filters inside the oil tank, so it is very important to only use clean filtered oil when replacing fluid oil in the tank. The oil flow from the outlet of the three main drive pumps goes to the main drive manifold assembly.

**Drive manifold:** The main drive manifold assembly consists of the main forward and reverse directional control valve and the pilot directional control valve (which operates the main directional control valve). Included in the main drive manifold assembly is the drive pressure relief valve which limits the main drive operation pressure. A shuttle valve used to sense forward or reverse and send the pressure signal to the main drive relief valve. A needle valve is used to control the speed of the pressure signal and oil flow, so as to not overload the main drive relief valve.

**Example of typical forward operation:** Flow from the pump outlets travels to the main drive directional control valve. If no action by the operator to push a forward or reverse control button, then the oil flow passes through the directional control valve, from **Port P** to **Port T** and back to tank. The vibro does not run. When the operator pushes the forward control button, then an electrical signal is sent to the pilot directional control valve, which then sends pilot oil pressure to the main directional control valve, which will shift the main directional control valve and allow oil flow to pass from **Port P** to **Port A** of this valve, sending oil flow to the vibro turning the vibro forward. The returning oil from the vibro enters **Port B** to **Port T** of the control valve and returns to the oil tank. Should the hydraulic pressure increase beyond limits, the main drive relief valve will see this pressure increase and limit system maximum pressure to 4800-psi.

The reverse vibro operation is the same, except that the pilot control valve will reverse pilot oil pressure to the main drive directional control valve and oil flow will be from **Port P** to **Port B** out to the vibro and **Port A** to **Port T** oil flow back to the oil tank. The needle valve is factory set and does not require adjustment in the field. The main drive pressure relief valve is factory set at 4800-psi maximum hydraulic system pressure. Engine speed should remain constant at 2100-rpm, and forward and reverse maximum hydraulic pressure is limited to 4800-psi.

# OPERATION / MAINTENANCE MANUAL

MODEL 400 TANDEM VIBRATORY HAMMER WITH  
MODEL 1000 POWER UNIT

7032 So. 196th - Kent, WA. 98032 - (253) 872-0141 / Fax (253) 872-8710

## VII. MODEL 1000 POWER UNIT (Continued...)

### VII-2E. Hydraulic Circuits & Manifolds (Continued...)

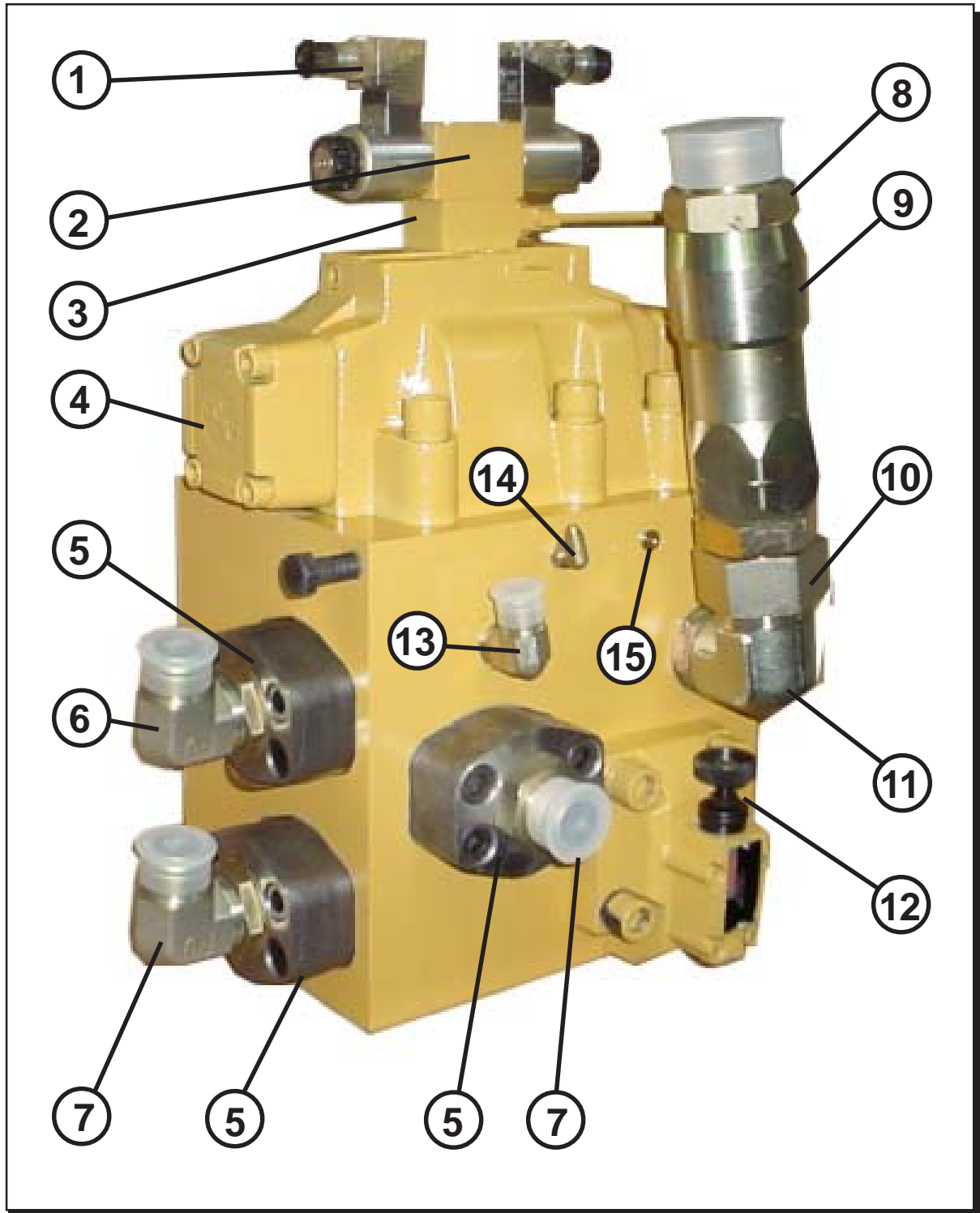

**Figure 7-J. Drive Manifold (APE P/N 513028)**



# OPERATION / MAINTENANCE MANUAL

MODEL 400 TANDEM VIBRATORY HAMMER WITH  
MODEL 1000 POWER UNIT

7032 So. 196th - Kent, WA. 98032 - (253) 872-0141 / Fax (253) 872-8710

## VII. MODEL 1000 POWER UNIT (Continued...)

### VII-2E. Hydraulic Circuits & Manifolds (Continued...)

ITEM	QTY	DESCRIPTION	MFG	MFG P/N
1	2	DIN Connector	PPT	Z55L
2*	1	Solenoid Valve	PPT	4WE6J6X/EG24N9K4
3	1	Shuttle Body	Sun	GBS-S (APE 513030)
4	1	Control Valve	PPT	4WEH32H6X/6EG24N9EK4
5	3	4-Bolt Flange & Kit		W48 24-24U
6	1	Fitting		C50X 20-24 C50XS
7	2	Fitting		20-24 F50X-S
11	1	Fitting		32-24C50X-S
12	1	Relief Valve	PPT	DB30-1-5X/350X/12
13	1	Fitting		12-8 C50X
14	1	Fitting		4-4 C50X
15	1	Fitting		4-HP50N
2*		Consists of Body Shuttle Valve Fittings	PPT PPT PPT	Sun GBS/S Body T-13A CSAA-EXN Shuttle 0503-4-4

NOTE: ITEMS 8, 9, 10 NOT USED ON MODEL 1000 POWER UNIT

**Table 7-B . Drive Manifold Identification**

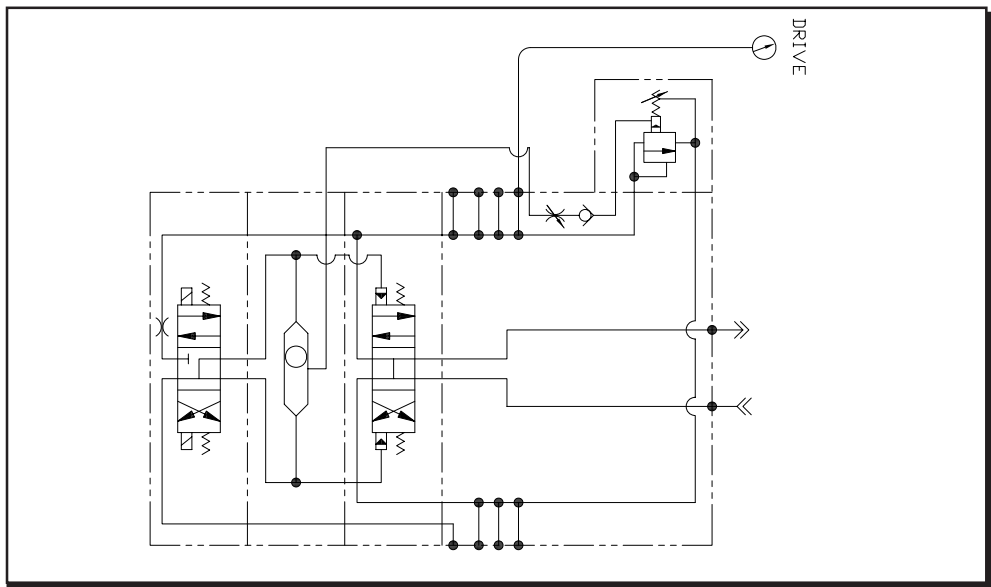

**Figure 7-K . Drive Manifold Schematic**

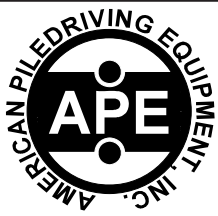

# **OPERATION / MAINTENANCE MANUAL**

**MODEL 400 TANDEM VIBRATORY HAMMER WITH  
MODEL 1000 POWER UNIT**

7032 So. 196th - Kent, WA. 98032 - (253) 872-0141 / Fax (253) 872-8710

## **VII. MODEL 1000 POWER UNIT (Continued...)**

### **VII-2E. Hydraulic Circuits & Manifolds (Continued...)**

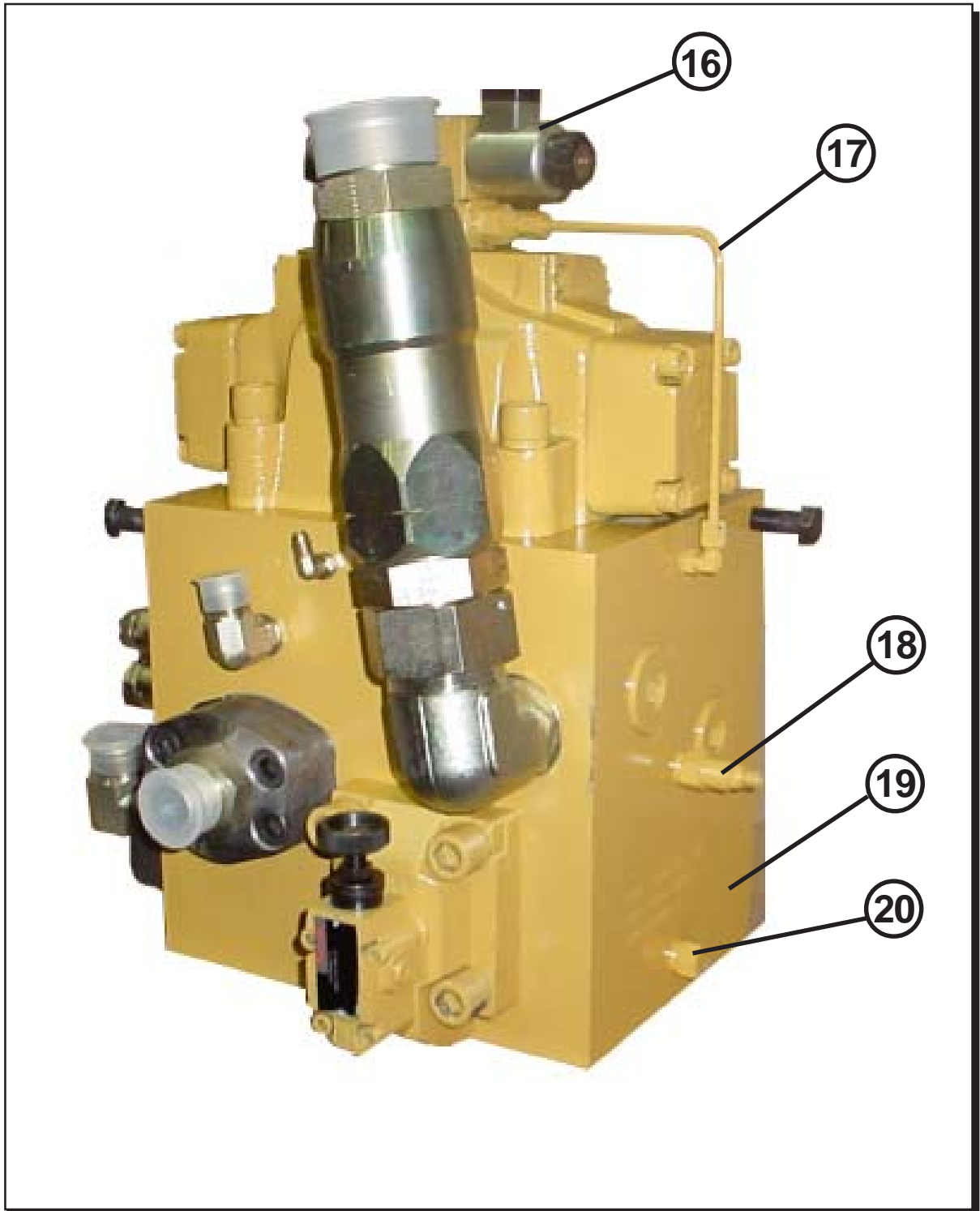

**Figure 7-L. Drive Manifold (APE P/N 513028)**



# **OPERATION / MAINTENANCE MANUAL**

**MODEL 400 TANDEM VIBRATORY HAMMER WITH  
MODEL 1000 POWER UNIT**

7032 So. 196th - Kent, WA. 98032 - (253) 872-0141 / Fax (253) 872-8710

## **VII. MODEL 1000 POWER UNIT (Continued...)**

### **VII-2E. Hydraulic Circuits & Manifolds (Continued...)**

<b>ITEM</b>	<b>QTY</b>	<b>DESCRIPTION</b>	<b>MFG</b>	<b>MFG P/N</b>
16	2	Solenoid Coil	PPT	R900221884
17	1	Tube	PPT	
18	1	Cartridge Valve	PPT	NFCC-LCN
19	1	Drive Manifold Block	PPT	MA-06840
20	1	Cartridge Valve - Ck.	PPT	CXDA-XCN

**Table 7-B. Cont.**





# OPERATION / MAINTENANCE MANUAL

## MODEL 400 TANDEM VIBRATORY HAMMER WITH MODEL 1000 POWER UNIT

7032 So. 196th - Kent, WA. 98032 - (253) 872-0141 / Fax (253) 872-8710

### VII. MODEL 1000 POWER UNIT (Continued...)

#### VII-2E. Hydraulic Circuits & Manifolds (Continued...)

##### CLAMP CIRCUIT

The clamp hydraulic circuit consists of the clamp piston pump (rated at 10-gpm and 5000-psi maximum). Fluid is drawn through the manual shut-off valve into the clamp pump inlet, and then directed to the clamp manifold assembly. The clamp manifold assembly consists of the following parts: the clamp main relief valve (to limit maximum clamp pressure), a check valve (to prevent reverse fluid flow), a directional control valve (for opening and closing the clamp cylinder), a pilot check valve, ( to trap fluid and lock the clamp in the closed position), and a pressure switch (to sense the clamp pressure close pressure).

**A typical clamp close operation:** fluid flows from the clamp pump to the **P port** of the directional control valve, and back to the oil tank through **Port T**. When the operator energizes the clamp close button, the directional control valve will shift, and allow fluid flow to travel from **Port P** to **Port A** to through the pilot check valve, and close the cylinder.

**A typical clamp open operation:** fluid flows from the clamp pump to the **P port** of the directional control valve and back to the oil tank through **Port T**. When the operator energizes the clamp open button, the directional control valve will shift, and allow fluid flow to travel from **Port P** to **Port B** to the open side of the clamp cylinder. The return flow from the clamp cylinder cannot pass through the pilot check valve until enough hydraulic pressure builds to unlock the pilot check valve. This is done to make sure a positive hydraulic pressure is needed to open the clamp assembly. Fluid flow from the clamp cylinder will return to oil tank from **Port A** to **Port T**. When released, the clamp close button will allow the directional control valve to de-energize and allow the fluid flow from the clamp pump to travel from **Port P** to **Port T** and back to oil tank.

**Notes;** It is important to understand that the clamp pressure switch only works on the clamp close side of the circuit to maintain clamp close pressure during vibro operation. Clamp close pressure switch is factory set at 4400-psi, and the main clamp relief valve is set at 4800-psi maximum. Should an internal leak happen in the clamp cylinder, then the clamp close pressure switch will cycle on/off all the time. This shows the operator that a leak is in the clamp cylinder and the pressure switch is re-energizing the clamp close directional control valve and trying to maintain clamp close pressure.

### VII. MODEL 1000 POWER UNIT (Continued...)

#### VII-2E. Hydraulic Circuits & Manifolds (Continued...)

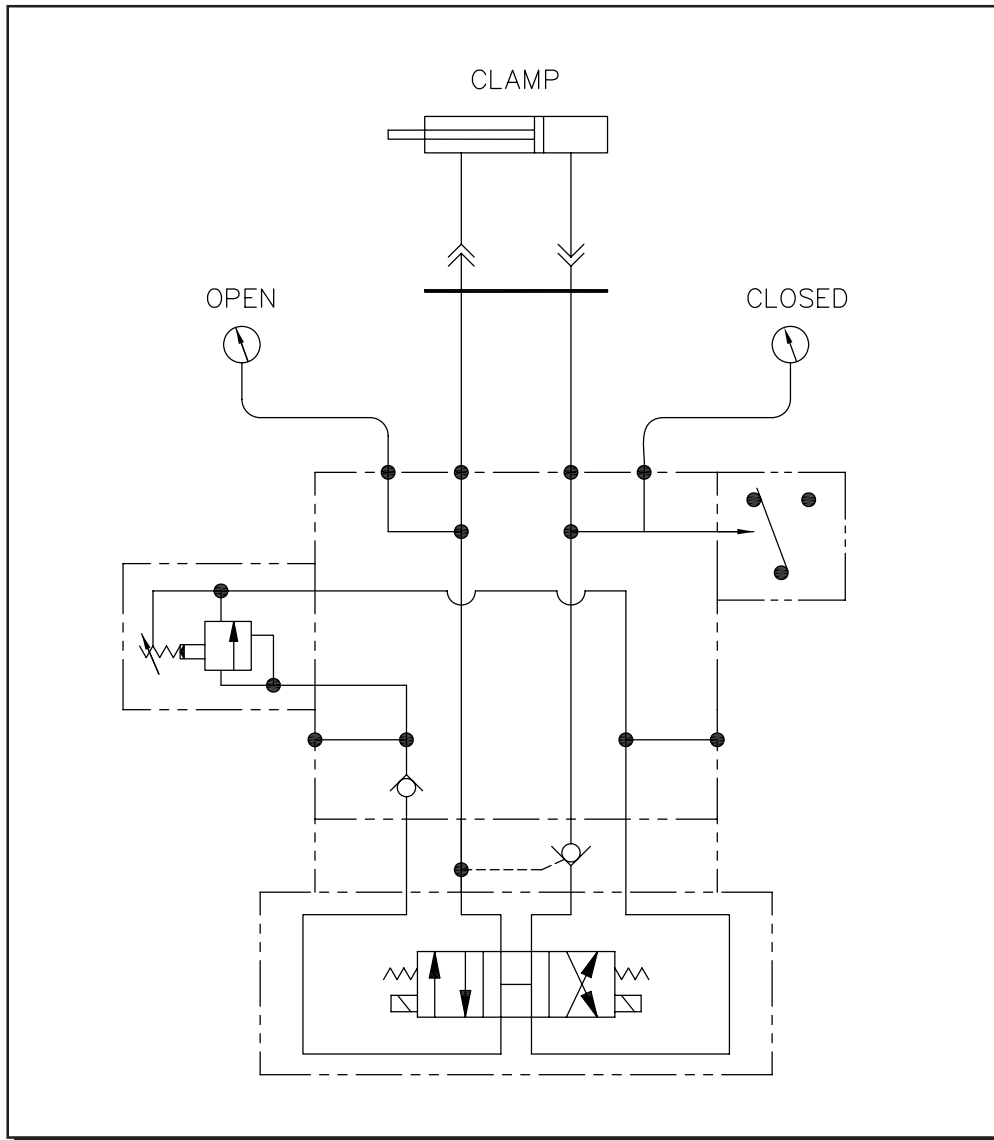

**Figure7-M . Clamp Manifold Schematic**

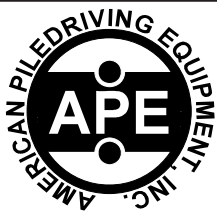

# OPERATION / MAINTENANCE MANUAL

MODEL 400 TANDEM VIBRATORY HAMMER WITH  
MODEL 1000 POWER UNIT

7032 So. 196th - Kent, WA. 98032 - (253) 872-0141 / Fax (253) 872-8710

## VII. MODEL 1000 POWER UNIT (Continued...)

### VII-2E. Hydraulic Circuits & Manifolds (Continued...)

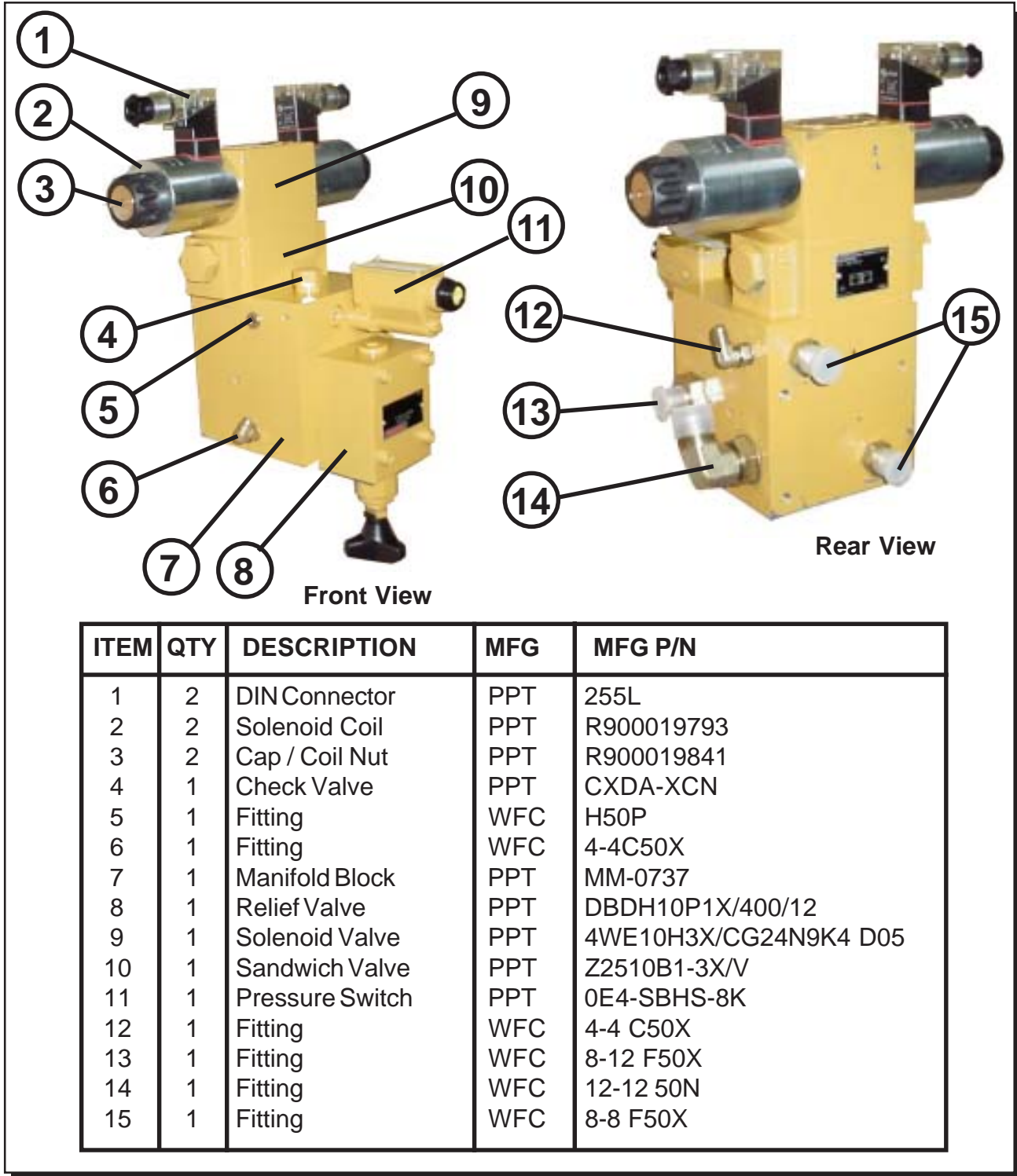

ITEM	QTY	DESCRIPTION	MFG	MFG P/N
1	2	DIN Connector	PPT	255L
2	2	Solenoid Coil	PPT	R900019793
3	2	Cap / Coil Nut	PPT	R900019841
4	1	Check Valve	PPT	CXDA-XCN
5	1	Fitting	WFC	H50P
6	1	Fitting	WFC	4-4C50X
7	1	Manifold Block	PPT	MM-0737
8	1	Relief Valve	PPT	DBDH10P1X/400/12
9	1	Solenoid Valve	PPT	4WE10H3X/CG24N9K4 D05
10	1	Sandwich Valve	PPT	Z2510B1-3X/V
11	1	Pressure Switch	PPT	0E4-SBHS-8K
12	1	Fitting	WFC	4-4 C50X
13	1	Fitting	WFC	8-12 F50X
14	1	Fitting	WFC	12-12 50N
15	1	Fitting	WFC	8-8 F50X

Figure 7-N. Model 1000 Clamp Manifold (APE P/N 523002)



# **OPERATION / MAINTENANCE MANUAL**

## **MODEL 400 TANDEM VIBRATORY HAMMER WITH MODEL 1000 POWER UNIT**

7032 So. 196th - Kent, WA. 98032 - (253) 872-0141 / Fax (253) 872-8710

### **VII. MODEL 1000 POWER UNIT (Continued...)**

#### **VII-2E. Hydraulic Circuits & Manifolds (Continued...)**

##### **Cooling and Filtration.**

A full time fluid flow from the cooling and filtration pump rated at 120 gpm and 65 psi is used to cool and filter all oil tank fluid. Fluid flow comes from the oil tank through a manual shut-off valve, to the cooling pump inlet. This flow is always flowing whenever the diesel engine is running. Fluid flow from the cooling pump outlet travels to the air/oil cooler located in front of the diesel engine radiator. There is a 65-psi check valve located in parallel with the air/oil cooler, to limit cooling pressure to 65-psi maximum. From the air/oil cooler, the fluid travels to a return filter, back to the oil tank. This cooling circuit provides a constant cooling and filtration of oil tank fluid.

##### **Manual Fill Pump**

A manual pump is used to re-fill the oil tank with hydraulic fluid. This fluid also travels through the return filter before entering the upper oil tank, used as a spare fluid storage. The lower or (main oil tank) is filled by opening a manual shut-off valve, allowing fluid to gravity flow from the spare oil tank into the lower or main oil tank.

##### **Fluid Temperatures**

Fluid temperatures should be keeping to a maximum of 180°F (82°C), and suggested normal operating temperature between 110°F (43°C) and 150°F (65°C). When hydraulic unit is operating in very low ambient temperatures, ((-10°F (-23°C)) it is suggested to start diesel engine and allow hydraulic fluid to rise in temperate as least 20°F (-12°C) before running hydraulics. It is better to operate the hydraulics at a slow operation for a time allowing warming of hydraulic fluid. Consult American Piledriving Equipment, Inc. for extreme low temperatures requiring hydraulic operation.



# OPERATION / MAINTENANCE MANUAL

MODEL 400 TANDEM VIBRATORY HAMMER WITH  
MODEL 1000 POWER UNIT

7032 So. 196th - Kent, WA. 98032 - (253) 872-0141 / Fax (253) 872-8710

## VII. MODEL 1000 POWER UNIT (Continued...)

### VII-1F. Hydraulic Components

ITEM	QTY	DESCRIPTION	MFG	MFG P/N	APE P/N
1	3	Drive Pump	Commercial	P465B-278-BI-AB15-SPL-AB15-1	533014
2	1	Recirculation Pump	Commercial	P365B-278-BI-AB20-7-SPL-AB17-1	-----
3	1	Clamp Pump	Rexroth		533012
4	1	Drive Manifold	Pacific Power		-----
5	1	Clamp Manifold	Pacific Power		523002A
6	1	Hyd. Cooler	Spencer Ind.	DB 5371	-----
7	1	100 psi Gauge	Western Fluids		513007A
8	3	1750 psi Gauge	Western Fluids		513007
9	1	6" Level Gauge	Western Fluids	G607-06-1-1-1 1/2	513003
10	1	30" Level Gauge	Western Fluids	G607-30-A-1 1/2	513005
11	1	1" Breather	Western Fluids	ABS-40-N16	513002
12	1	Filler Filter	Western Fluids	OFRS25P10	513053
13	1	Hand Pump	Western Fluids	PA414	513010
14	1	1-1/4" Swing CV	Western Fluids		513011
15	4	Lighted DIN Conn.	Western Fluids	GDM2011114	513048
16	1	Level Gauge - Fuel	Western Fluids	8680-L95	513050
17	2	Clamp Assembly	Western Fluids	PPH-51660-SCP-HEX	513041
18	1	Suction Header Kit	Western Fluids		-----
19	1	Model 100 Hose Kit	Western Fluids		553500
20	1	Oil Temp Gauge	Inst. Sales	Murphy Type 25T 25020	523016
21	1	Oil Press Gauge	Inst. Sales	Murphy Type 20P100	521052
22	1	Murphy Gauge	Inst. Sales		521053
23	1	Water Temp Gauge	Inst Sales	Murphy Type 20T25010	531064
24	1	Pump Drive	Spencer Ind.		552001
25	4	Block Flange	Pacific Rubber		-----
26	1	Control Panel	Controlled Pwr.		541004
27	1	Control Pendant	Controlled Pwr.		511006
28	1	Oil Level Switch		Murphy Type L 120	513033
29	1	Engine Oil Line		F4-K-P2-2670(B)	521053
30	1	Return Filter Pall			543051
31	1	Filter Element			533003
32	1	QD Set			400100
33	1	Dust Cap			400713A
34	1	Dust Plug			400704A
35	1	Vacuum Switch			531006
36	1	Throttle Actuator		AC 721-0103	511051
37	1	2" Check Valve			513040

**Table 7-C. Model 1000 Hydraulic Components**

# OPERATION / MAINTENANCE MANUAL

MODEL 400 TANDEM VIBRATORY HAMMER WITH  
MODEL 1000 POWER UNIT

7032 So. 196th - Kent, WA. 98032 - (253) 872-0141 / Fax (253) 872-8710

## VII. MODEL 1000 POWER UNIT (Continued...)

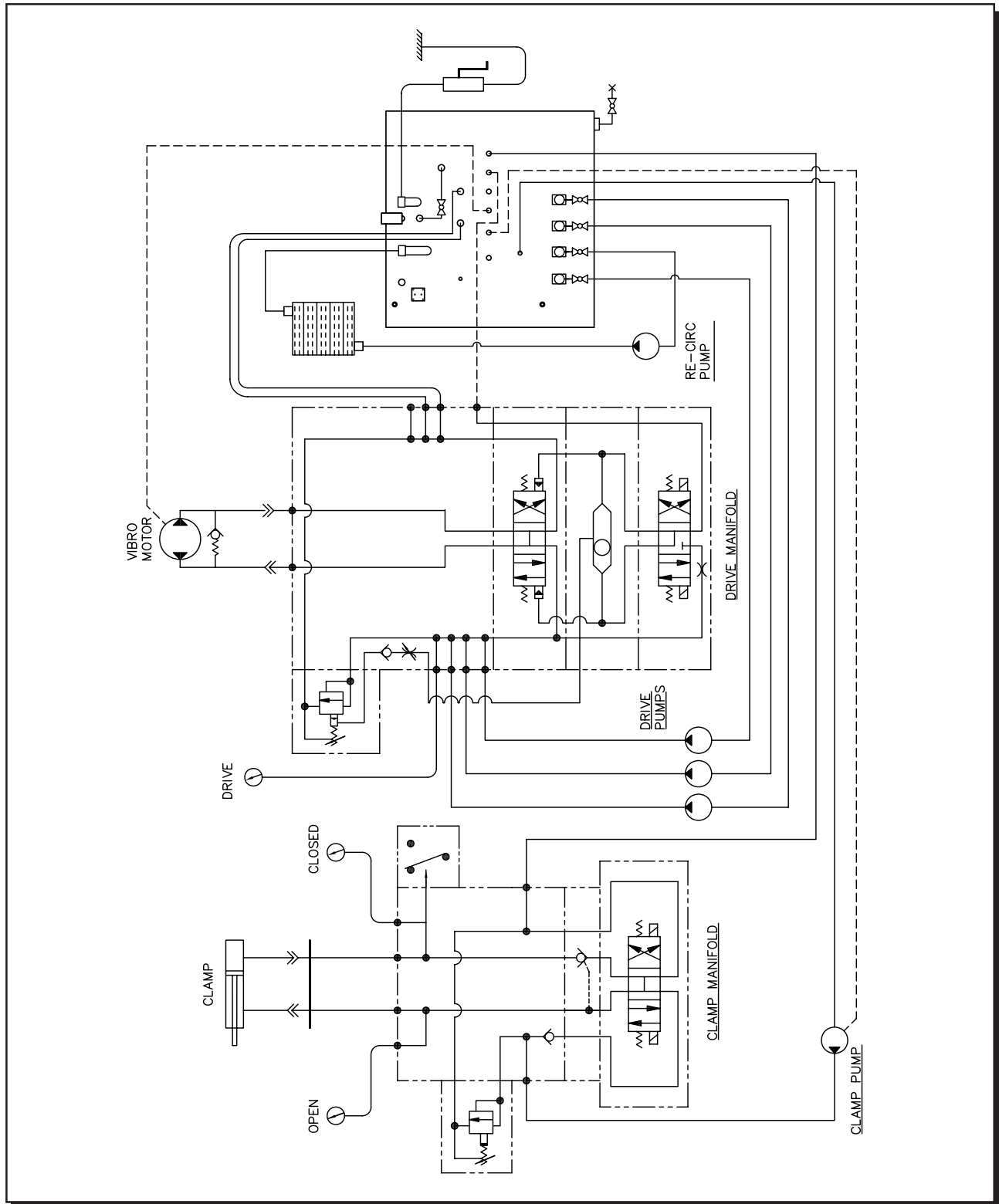

**Figure 7-O. Model 1000 Hydraulic Schematic**



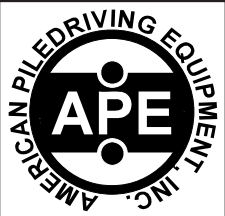

# OPERATION / MAINTENANCE MANUAL

## MODEL 400 TANDEM VIBRATORY HAMMER WITH MODEL 1000 POWER UNIT

7032 So. 196th - Kent, WA. 98032 - (253) 872-0141 / Fax (253) 872-8710

### VII. MODEL 1000 POWER UNIT (Continued...)

ITEM	SYM	QTY	DESCRIPTION	MFG.	PART NO.
1		1	Side Legend Plates	AAA	3700SP40
2	Lighted Clamp Open/Close Sw.	1	Illuminated 3 Position Spring Return From Left	A-B	800T-24JG4KB7AX
3	PM Aux Receptacle	1 1 1	PM 2 Socket Aux Receptacle PM Aux Receptacle Gasket PM Aux Receptacle Cover	Amphenol Amphenol Amphenol	MS3102A-12S-3-S 10-40450-12 MS25043-12D
4	PM Pendant Receptacle	1 1 1	PM 12 Socket Pendant Receptacle PM Pen Receptacle Gasket PM Pen Receptacle Cover	Amphenol Amphenol Amphenol	MS3102A28-18S 10-40450-28 MS25043-28D
5	PM Engine Receptacle	1 1	PM 23 Pin Engine Receptacle PM Engine Receptacle Gasket	Amphenol Amphenol	MS3102A32-6P 10-40450-32
6		1	Cat Door Silk Screen	ASP	CDSS2
7	S.O. Cord Hook Ups	5	Side PM Male Receptacle	Brad Harrison	1R3006A24A120
8	Normal/ Test	1 1	Toggle switch 2 pos SS Small Z Bracket	Carling Vulcan	2GL51-73XG 18200
9	Drive Rev Off Fwr Sw.	1 1 1	Three Position Operator (Maint) Contact Block, 2 N.O. Contact Block, 2 N.C.	C-H C-H C-H	10250T3023 10250T2 10250T3
10	Local Pendant Sw.	1 2	Two Position Operator (Maint) Contact Block, 2 N.O./2 N.C.	C-H C-H	10250T3011 10250T44
11	Governor R/L Sw.	1 1	Three Position Operator (Mom) Contact Block, 2 N.O.	C-H C-H	10250T3043 10250T2
12	Engine Control Sw.	1 1	Three Position Operator (Maint/Mom) Contact Block, N.O./N.C.	C-H C-H	10250T3053 10250T1
13	Sys. Ok Light	1	Lampholder Green Lens	C-H C-H	10250T206N 10250TC2N
14	VM	1	Volt Meter Gauge	Datcon	100265
15	HRM	1	Hour Meter Gauge	Datcon	100223
16	SS	1	Speed Switch	ECU	ECU-SS40
17	DHRM	1 1	Drive Hour meter Bracket	Hobbs Hobbs	85094-12 23944
18		1	3/4" - 3/8" - 1/2" Cord Connector	Hubbell	SHC1035CR
19		1	3/4" Cord Connector	Hubbell	SHC1036CR
20	OPL,HOTL, HOLL,CTL, IFL,SP1	6	Red L.E.D.	Idec	AP8M222-R
21	Diognostic	1	Amber L.E.D.	Idec	AP8M222-A
22		1	Terminal End Section	Idec	BNE15W
23		2	Terminal Block	Idec	BNH15LW
24		40	Terminal Bock	Idec	BNH15MW
25		2	Terminal End Clamp	Idec	BNL5
26	OPR,ECMR	2 2	Lighted Relay, DPDT Relay Base, 2 Pole	Idec Idec	RH2BUL-24VDC SH2B-05C
27		14	Diode	I-R	60S6
28	Engine Fault	1	Mag Switch	Murphy	117PH
29	CB	1	Circuit Breaker, 10 Amp	P&B	W58-XC4C12A-10
30	CB1, CB2	2	16 Amp CB	Seimens	5SX2116-8
31	TT	1	Tach Transducer	Red Loin	IFMA0035
32		5	1/2" Lock Nut	Regal	801
33		2	3/4" Lock Nut	Regal	802
34		2	3/4" Rubber Gasket	T&B	5303
35		4	Shock Mount Legs (1/4")	VIBRATION	40B
36		1	SS Enclosure/Back Pan	Vulcan	Stainless

**Table 7-D. Model 1000 Control Panel Components**





# OPERATION / MAINTENANCE MANUAL

## MODEL 400 TANDEM VIBRATORY HAMMER WITH MODEL 1000 POWER UNIT

7032 So. 196th - Kent, WA. 98032 - (253) 872-0141 / Fax (253) 872-8710

### VII. MODEL 1000 POWER UNIT (Continued...)

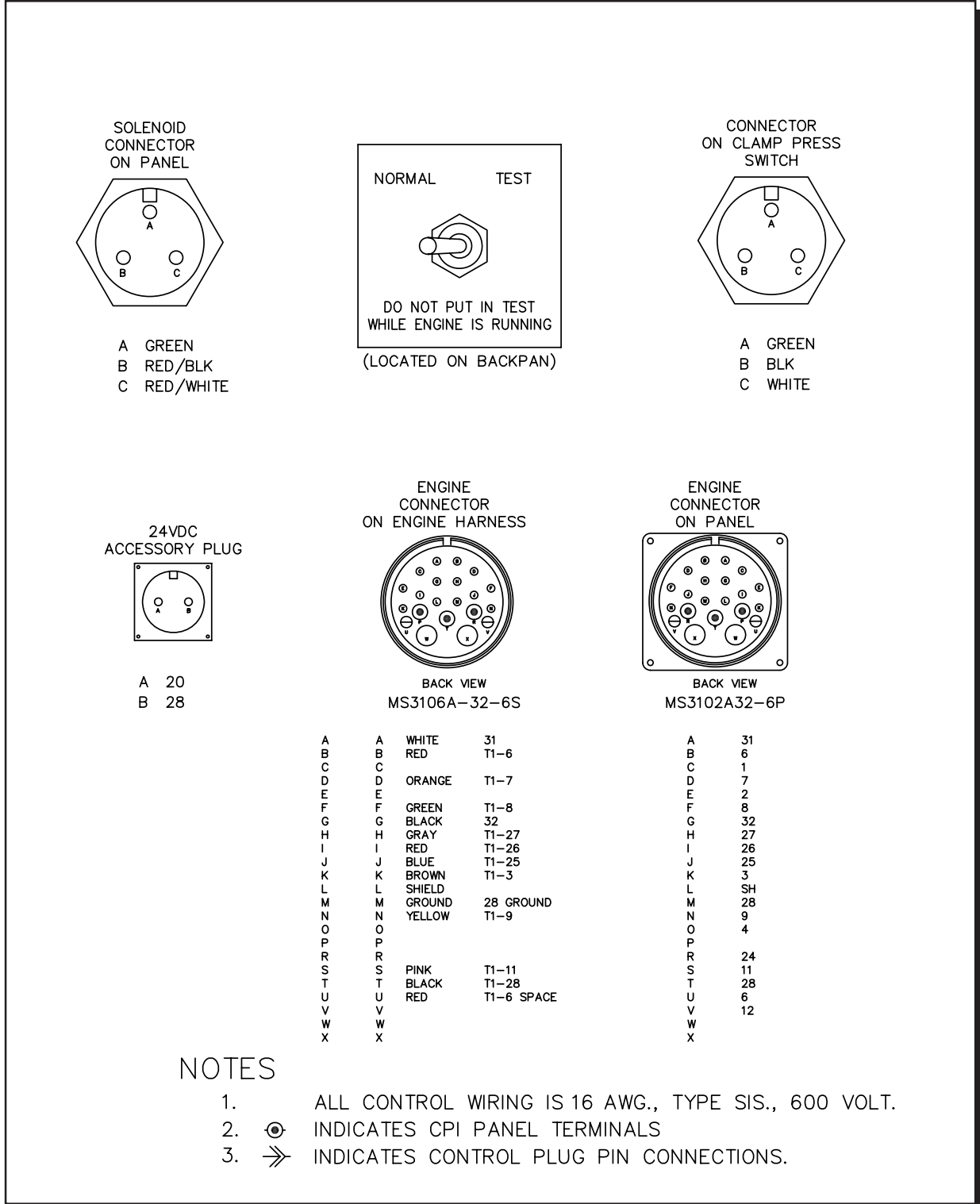

#### NOTES

1. ALL CONTROL WIRING IS 16 AWG., TYPE SIS., 600 VOLT.
2. ⊙ INDICATES CPI PANEL TERMINALS
3. ➞ INDICATES CONTROL PLUG PIN CONNECTIONS.

**Figure 7-Q. Control Panel Electrical Connectors**



# **OPERATION / MAINTENANCE MANUAL**

## **MODEL 400 TANDEM VIBRATORY HAMMER WITH MODEL 1000 POWER UNIT**

7032 So. 196th - Kent, WA. 98032 - (253) 872-0141 / Fax (253) 872-8710

### **VII. MODEL 1000 POWER UNIT (Continued...)**

#### **VII-2G. Control Panel (Continued...)**

##### **1. Engine Control Switch "OFF/ON/START"**

The ENGINE CONTROL SWITCH is used to start and stop the diesel engine. Turning it to "ON" turns on all power to the panel. Turning to START energizes the engine starter solenoid which activates the starter motor which turns the diesel engine flywheel and causes the engine crankshaft to turn which, through various mechanical actions, acts on the fuel pump. As the engine turns, the fuel pump injects fuel into the combustion chamber of each piston cylinder at timed intervals and as the engine continues to crank, fuel and air is compressed in the combustion chamber by each piston as it comes up on the compression stroke. As the pistons compress fuel and air, the fuel and air mix into a combined gas that ignites under pressure when each piston nears the top of its stroke the gas explodes, forcing the piston downward and converts thrust into torque via a connecting rod pinned to the piston and mounted to a crankshaft. When the piston reaches the bottom of the cylinder, it begins its upward travel and an exhaust valve at the top of the cylinder opens, forcing unburned gases out. When the piston reaches the top, the exhaust valve closes and an intake valve opens as the piston travels back downward. The piston sucks new air into the combustion chamber while the fuel injector adds fuel. These four cycles of intake, compression, ignition and exhaust continue until the engine fuel delivery is cut off.

Once the engine is rotating on its own power, the switch is released. The switch returns to the "ON" position because it is spring loaded in that direction. To turn the engine off, the switch is turned to the "OFF" position, which sends a grounded signal that activates the ENGINE SAFETY SHUT DOWN SWITCH which then cuts power to the fuel solenoid and stops the engine.

##### **2. "LOCAL/REMOTE" Switch.**

The LOCAL/REMOTE SWITCH is used to allow the operator to control the power unit from either the CONTROL PANEL or the REMOTE HAND HELD PENDANT. The LOCAL /REMOTE SWITCH must be in the LOCAL position to start the engine.



# **OPERATION / MAINTENANCE MANUAL**

## **MODEL 400 TANDEM VIBRATORY HAMMER WITH MODEL 1000 POWER UNIT**

7032 So. 196th - Kent, WA. 98032 - (253) 872-0141 / Fax (253) 872-8710

### **VII. MODEL 1000 POWER UNIT (Continued...)**

#### **VII-2G. Control Panel (Continued...)**

##### **3. Clamp "OPEN/OFF/CLOSE" Switch.**

The CLAMP OPEN/OFF/CLOSE SWITCH is used to control the direction of the hydraulic flow coming from the clamp pump. When the engine is running and the switch is in the "OFF" position, all clamp PUMP oil is returned to the tank. Turning the CLAMP CLOSE/OFF/OPEN SWITCH to the close position energizes the clamp close solenoid, which can be observed with the lighted connector. When the close solenoid energizes, the clamp close valve closes sending hydraulic oil to the closed side of the clamp cylinder. When the pressure reaches 4000 psi, the CLAMP PRESSURE SWITCH (located on the clamp manifold) opens, de-energizing the closed solenoid and lighting a lamp in the CLAMP OPEN / OFF / CLOSE SWITCH and the green lamp on the remote HAND HELD PENDANT. If the pressure drops below 3800 psi, the CLAMP PRESSURE SWITCH closes allowing the close solenoid to recharge the clamp close hydraulic circuit. Note: If the light on the solenoid stays on and the green light on the pendant fails to come on then the pressure switch may be faulty. Do not operate the machine if you can see the clamp closed solenoid light on all the time. (Note: the clamp closed solenoid light is located on the solenoid.) It should go off as soon as the jaws close and the pressure rises above 3800 psi. When jaws are closed properly, the green light will glow on the remote pendant, or if operating from the panel, the green light is built into the switch. When the diesel engine is running, Turning the clamp switch to "OPEN" energizes the open solenoid and directs oil to the open side of the clamp cylinder and the jaws open.

##### **4. Drive "FORWARD/REVERSE" Switch.**

The DRIVE FORWARD/REVERSE SWITCH is used to control the hydraulic motors on the vibrator or for supplying forward and reverse direction on a drill. With the engine running and the DRIVE FORWARD / REVERSE SWITCH in the forward position, the forward drive solenoid energizes, which can be observed with the lighted connector. With the forward drive solenoid energized, the forward valve opens, sending hydraulic fluid to the hydraulic motors, and the motors rotate. With the engine running and DRIVE FORWARD / REVERSE SWITCH in the reverse position, the reverse drive solenoid energizes, which can be observed with the lighted connector. With the reverse drive solenoid energized, the reverse valve sends oil to the vibrator motors but the motors do not rotate because all oil flow is directed around the motors via the ANTI-CAVITATION CHECK VALVE located on the vibro suppressor housing and plumbed into the hoses leading to and from the hydraulic motors. Therefore, the vibrator runs in the forward direction only, and this direction is used for driving or pulling all piles. The reverse direction is used when the power unit is supplying oil to a drill or other attachment or when flushing the oil during initial startup.

##### **5. "SYSTEM OK" Light.**

The "SYSTEM OK" Light is lighted when the engine is running and all systems are normal.

##### **6. "SPARE" Light.**



# **OPERATION / MAINTENANCE MANUAL**

**MODEL 400 TANDEM VIBRATORY HAMMER WITH  
MODEL 1000 POWER UNIT**

7032 So. 196th - Kent, WA. 98032 - (253) 872-0141 / Fax (253) 872-8710

## **VII. MODEL 990 POWER UNIT (Continued...)**

### **VII-2G. Control Panel (Continued...)**

#### **7. Throttle "RAISE/OFF/LOWER" Switch.**

This switch is used to throttle the engine up or down. This switch turns a small motor hooked to the engine throttle. APE power units with CAT engines use a system supplied by CAT. The CAT engine throttle requires two small relays mounted inside the control panel. The APE units with Cummins engines do not have relays and are wired directly to a Murphy worm drive throttle box mounted on the engine.

#### **8. "OIL PRESSURE" Gauge:**

An electric "OIL PRESSURE" Gauge is provided to monitor engine oil pressure. The CAT oil pressure gauge is wired to an oil pressure sender that forces the gauge to read zero pressure when the power is turned on. The CAT sender is a variable resistor that is normally grounded and slowly decreases the grounded voltage as pressure is delivered to it. As the voltage decreases, the pressure gauge reading increases. To test the sender, disconnect the wire leading to it and place one OHM meter lead on the sender terminal and the other lead on the engine. It should show maximum resistance. If not, replace it.

#### **9. "ENGINE OIL PRESSURE" Switch:**

A small ENGINE OIL PRESSURE Switch mounted on the diesel engine is designed to ground out when pressure drops below 40 psi. The switch is designed to be normally open when under pressure. When pressure is lost, the switch closes sending a grounded signal that activates the safety shut down switch on the panel which cuts power to the fuel solenoid and shuts down the engine.

#### **10. "WATER TEMPERATURE" Gauge:**

An electric "WATER TEMPERATURE" Gauge is provided to monitor engine water temperature.



# **OPERATION / MAINTENANCE MANUAL**

## **MODEL 400 TANDEM VIBRATORY HAMMER WITH MODEL 1000 POWER UNIT**

7032 So. 196th - Kent, WA. 98032 - (253) 872-0141 / Fax (253) 872-8710

### **VII. MODEL 1000 POWER UNIT (Continued...)**

#### **VII-2G. Control Panel (Continued...)**

##### **12. "WATER TEMPERATURE" Switch:**

A water temperature switch is mounted on the engine. It is a normally "open" switch. If the water temperature increases to a level that may damage the engine, the switch closes, sending a grounded signal that activates the "ENGINE SAFETY SHUTDOWN" Switch located on the panel. This switch can give a faulty signal and cause the engine to shut down even when water temperature is normal. To test the switch, disconnect the wire leading to it. Test the switch using an OHM meter by placing one OHM lead to the switch terminal and one to the grounded engine. You should not see a reading on the OHM meter (provided the water temperature is below 207 degrees F.). If the OHM meter shows resistance then replace the switch.

##### **13. "FUEL PRESSURE" Gauge:**

An electric FUEL PRESSURE Gauge is provided to monitor engine fuel pressure. An electrical variable resistor mounted on the fuel system sends a signal to the gauge. The sender is designed to send a signal to the panel gauge as pressure increases which increases the gauge reading.

##### **14. "TACHOMETER"**

A "TACHOMETER" is provided to monitor the engine speed for optimum operation. The tachometer is digital and operates off a magnetic pickup that receives a signal from the flywheel of the engine. Note: If the tachometer seems to be reading wrong, check with a photo tach. Adjustments can be made on the back of the tachometer. Consult factory for proper setting of tach switches.

#### **VII-2C. Preparing The Electrical System For Start-Up.**

To start the engine the (CIRCUIT BREAKER) should be in the "ON" position (PUSHED IN AND LOCKED) and the FORWARD/OFF/REVERSE switch both on the panel and on the pendant should be in the off position. The engine will not start if the DRIVE/OFF/FORWARD switch is in the "ON" position. This prevents the operator from accidentally starting the engine and setting the vibrator or drill into motion the moment the engine starts.

#### **VII-2D. Engine Safety Shut-Down Button Switch.**

The "ENGINE SAFETY SHUT DOWN BUTTON SWITCH" turns on and off the fuel solenoid that is mounted on top of the engine. The button must be depressed in order to get power to the fuel solenoid and allow the engine to receive fuel to the fuel pump. Three safety switches: (1. Water Temperature, 2. Engine Oil Pressure and 3. Hydraulic oil level) on the power unit are wired into the "ENGINE SAFETY SHUT DOWN BUTTON SWITCH" and will shut the engine off automatically if any of these three switches is closed. (Please see "Engine Safety Shut-Down (Three Causes Of Engine Shut-Down)" in this manual for detailed instructions on how these switches work and read the TROUBLESHOOTING SAFETY SHUT DOWN SWITCHES in this manual to render repairs. It is very simple, please make the effort to read and understand these switches and how they work.)



# **OPERATION / MAINTENANCE MANUAL**

## **MODEL 400 TANDEM VIBRATORY HAMMER WITH MODEL 1000 POWER UNIT**

7032 So. 196th - Kent, WA. 98032 - (253) 872-0141 / Fax (253) 872-8710

### **VII. MODEL 1000 POWER UNIT (Continued...)**

#### **VII-2G. Control Panel (Continued...)**

If the button pops back out the moment you release your finger from the button, then one or more of the three shut down switches is closing and grounding the "ENGINE SAFETY SHUT DOWN SWITCH". This will happen for the described in the following section of this manual.

#### **Engine Safety Shut-Down (Three Causes Of Engine Shut-Down).**

##### **1. No Oil Pressure:**

The engine oil pressure is used to open and hold open a small pressure switch mounted on the diesel engine. The engine oil pressure holds open the oil pressure switch as long as the engine is running and there is proper engine oil pressure. If the oil pressure drops, (NO OIL PRESSURE COULD RESULT IN A DESTROYED ENGINE) the switch closes and grounds the ENGINE SAFETY SHUT DOWN SWITCH located on the control panel which activates and cuts power to the fuel solenoid and shuts the engine down, saving the engine from possible damage due to lack of oil. Sometimes the oil pressure switch fails and sends a grounded signal to the "ENGINE SAFETY SHUT DOWN SWITCH" even when the oil pressure is fine. Please read the section titled "TROUBLESHOOTING: ENGINE OIL PRESSURE SWITCH" in this manual if you think this may have happened.

##### **2. High Engine Coolant Temperature:**

The engine coolant or engine water temperature is controlled by a temperature switch. This switch, located on the front of the engine, is normally open when the coolant temperature is normal. If the engine coolant becomes too hot the switch closes and sends a grounded signal which activates the "ENGINE SAFETY SHUT DOWN SWITCH" located on the panel. When this happens, power is cut to the fuel solenoid and the engine stops which prevents the engine from overheating and destroying itself. Sometimes this switch fails to work properly and shuts the engine down even when the water temperature is fine. Please read the section titled "TROUBLESHOOTING: ENGINE WATER TEMPERATURE SWITCH" in this manual if you think this may have happened.

##### **3. Low Hydraulic Oil Temperature:**

The hydraulic oil level in the tank is controlled by an oil level switch that is normally open when oil is in the tank at an acceptable level for operation. If the hydraulic oil level drops below the required level, the switch will close and send a grounded signal activates the "ENGINE SAFETY SHUT DOWN SWITCH" located on the panel. When this happens, power is cut to the fuel solenoid and the engine stops which prevents the hydraulic pumps from destruction due to lack of hydraulic oil. Some times this switch fails to work properly and shuts the engine down even when the oil level in the tank is normal. Please read the section titled "TROUBLESHOOTING: HYDRAULIC OIL LEVEL SWITCH" in this manual if you hink this may have happened.

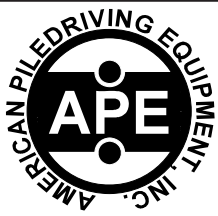

# OPERATION / MAINTENANCE MANUAL

## MODEL 400 TANDEM VIBRATORY HAMMER WITH MODEL 1000 POWER UNIT

7032 So. 196th - Kent, WA. 98032 - (253) 872-0141 / Fax (253) 872-8710

### VII. MODEL 1000 POWER UNIT (Continued...)

#### VII-2H. Remote Control Pendant.

A "REMOTE HAND HELD CONTROL PENDANT" is provided to allow operation of the power unit at a distance of up to 50 feet (15 meters) and can be extended using 50 foot extension cables. The "REMOTE HAND HELD CONTROL PENDANT" is connected to the control panel via a multiconnector plug.

This remote can be used to check all the electrical control valves by simply disconnecting the wire to the engine oil pressure switch and pushing in the safety shut down button and then turning on the star switch to the on position. Once this is done, you can walk over to the valves while holding the pendant in your hand. As you switch the valves you can see the lighted connectors go on and off on the top of the four solenoids: clamp open, close & drive forward and reverse.

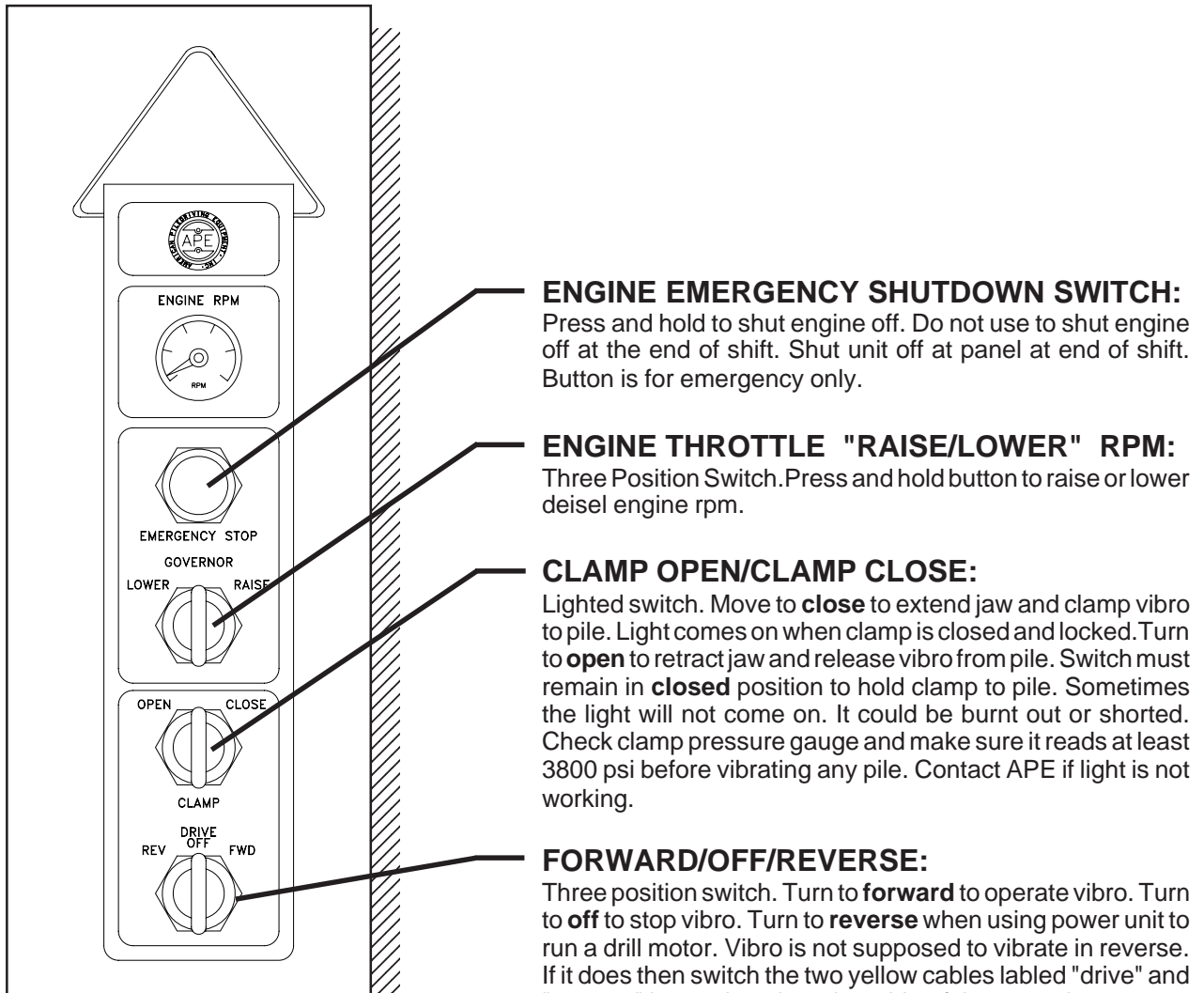

**Figure 7-R. Remote Control Pendant.**

**WARNING:** Never leave vibro clamped to a pile without the crane line attached. The clamp cylinder could bleed off causing the vibro to drop. Neverhoist a pile in the air without a safety line attached to the pile. Should the clamp close line become damaged and leak, the clamp cylinder could lose pressure and drop the pile.

# OPERATION / MAINTENANCE MANUAL

## MODEL 400 TANDEM VIBRATORY HAMMER WITH MODEL 1000 POWER UNIT

7032 So. 196th - Kent, WA. 98032 - (253) 872-0141 / Fax (253) 872-8710

### VII. MODEL 1000 POWER UNIT (Continued...)

#### VII-2H. Remote Pendant Electrical Connectors.

The following is the pin wiring configuration and the wire colors of the amphenol connectors for the remote control pendant cable.

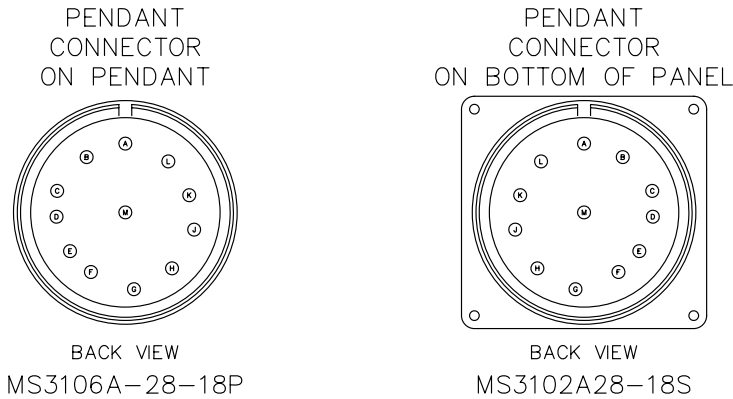

A	ORANGE	I-	A	I-
B	YELLOW	16	B	16
C	BROWN	40	C	40
D	RED/BLK	I+	D	I+
E	BLU/BLK	41	E	41
F	ORANGE/BLK	42	F	42
G	YLW/BLK	25	G	25
H	BRN/BLK	27	H	27
J	BLK/RED	43	J	43
K	BLUE	45	K	45
L	RED	46	L	46
M	BLACK	28	M	28

**Figure 7-S. Remote Pendant Electrical Connectors**

ITEM	SYM	QTY	DESCRIPTION	MFG.	PART NO.
1	Lighted Clamp Open/Close Sw.	1	Illuminated 3 Position Spring Return From Left	A-B	800T-24JG4KB7AX
		1	Diode	I/R	60S6
2	ESB	1	Flush Head Red Push Button	A-B	800T-A6D1
3	Drive Rev Off Fwr Sw.	1	3 Position Maintained Contact Block, 1N.O./N.C.	A-B	800T-J2KC1
		2	Diode	I/R	800T-XA 60S6
4	Governor R/L Sw.	1	3 Position Spring Return From Both	A-B	800T-J91A
5	Pendant Plug	1	CM 12 Pin Pendant Receptacle	Amphenol	MS3106A28-18P
		1	CM Pendant Receptacle Clamp	Amphenol	MS3057-16A
		1	Cable Clamp Rubber Inserts	Amphenol	MS3420-12
		1	CM Pen Receptacle Cover	Amphenol	MS25042-28D
6	Switch Descriptions	1	Standard Pendant Decal Set of 4	ASP	SPDS4
7	Engine RPM	1	Analog Meter 0-2500 rpm	Crompton	082-80R2-215256
		1	Diode	I/R	60S6
8	Pendant Plug Grip	1	Kellems Grip	Hubbell	073-10-003
9	Pendant Station Grip	1	Deluxe Cord Grip	Hubbell	074-01-017
10	Pendant Cable	50	16 Awg 14 Con. Pendant Cable	Perfaflex	F19061614
11	Pendant Station	1	4 Unit Pendant Box	Square-D	9001-SKYP-4

**Table 7-E. Remote Pendant Components**



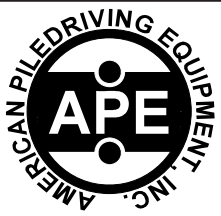

# **OPERATION / MAINTENANCE MANUAL**

## **MODEL 400 TANDEM VIBRATORY HAMMER WITH MODEL 1000 POWER UNIT**

7032 So. 196th - Kent, WA. 98032 - (253) 872-0141 / Fax (253) 872-8710

### **VII. MODEL 1000 POWER UNIT (Continued...)**

#### **VII-3. Troubleshooting: Power Unit Electrical.**

Use the following sections to help determine and solve problems that may arise within the power unit electrical system.

##### **VII-3A. Troubleshooting: Engine Oil Pressure Switch.**

The "ENGINE OIL PRESSURE SWITCH" is "open" when the engine is running so if this switch has shut down the engine, then it must be closing. Remove the wire from the switch and see if the engine will now run without the oil pressure switch connected. Make sure you do not have the wire that you just disconnected touching the engine or anything that could ground it. If the engine still shuts down the moment you let go of the "ENGINE SAFETY SHUT DOWN BUTTON SWITCH" then one of the other two safety switches is shutting down the engine. To test the switch, start the engine and use an OHM meter to see if the switch is open by placing one OHM meter lead on the switch terminal and the other OHM lead on the grounded engine. You should not show any resistance. If the engine is not running you should show resistance on the OHM meter because the switch will be closed. Replace switch if necessary.

##### **VII-3B. Troubleshooting: Engine Water Temperature Switch.**

The "ENGINE WATER TEMPERATURE SWITCH" is normally "open" and will only close if the water is too hot. If you think the engine has shut down because of a faulty temperature switch then remove the wire from the switch and try to start the engine again. If the engine is not running when you release your finger from the "ENGINE SAFETY SHUT DOWN SWITCH" then you have found your problem, it is the switch. To double check the switch, put one OHM meter lead on the switch and the other on a the grounded engine. OHM meter should show no reading. Replace if necessary.

##### **VII-3C. Troubleshooting: Hydraulic Oil Level Switch.**

The "HYDRAULIC OIL LEVEL SWITCH" is normally "open" when there is oil in the tank filled to the proper level. The switch is mechanically attached to a float that is submerged in the hydraulic oil tank. If the oil level drops, so does the float, and the switch will close if the oil level gets too low. It will also close if the oil level is just slightly above the float but the power unit is mounted on the back of a crane that is swinging so fast that the oil level is effected by the washing of the oil in the tank. When the switch closes, it sends a grounded signal that activates the "ENGINE SAFETY SHUT DOWN BUTTON SWITCH" located on the panel which cuts power to the fuel solenoid and shuts the engine down. The fuel solenoid must be energized to allow fuel to get to the fuel pump. If you think the "HYDRAULIC OIL LEVEL SWITCH" may be causing the engine to shut down, disconnect the wire at the float switch located on the hydraulic tank. Try to start the engine. If it runs even after you remove your finger from the "ENGINE SAFETY SHUT DOWN BUTTON SWITCH", then you have located your problem- the float switch is not working. To check, put one lead of the OHM meter on the terminal and the other lead on the ground. The meter should not show a reading. If it does, your oil is too low or the switch is bad. Replace it.



# **OPERATION / MAINTENANCE MANUAL**

**MODEL 400 TANDEM VIBRATORY HAMMER WITH  
MODEL 1000 POWER UNIT**

7032 So. 196th - Kent, WA. 98032 - (253) 872-0141 / Fax (253) 872-8710

## **VII. MODEL 1000 POWER UNIT (Continued...)**

### **VII-3. Troubleshooting: Power Unit Electrical. (Continued...)**

#### **VII-3D. Troubleshooting: Oil Pressure Sending Unit.**

An electric "OIL PRESSURE GAUGE" is provided to monitor engine oil pressure. The CAT oil pressure gauge is wired to an oil pressure sender that forces the gauge to read zero pressure when the power is turned on. The CAT sender is a variable resistor that is normally grounded and slowly decreases grounded voltage as pressure is delivered to it. As the voltage decreases, the pressure gauge reading increases. To test the sender, disconnect the wire leading to it and place one OHM meter lead on the sender terminal and the other lead on the engine. It should show maximum resistance. If not, replace it. CAT ONLY.



# OPERATION / MAINTENANCE MANUAL

## MODEL 400 TANDEM VIBRATORY HAMMER WITH MODEL 1000 POWER UNIT

7032 So. 196th - Kent, WA. 98032 - (253) 872-0141 / Fax (253) 872-8710

### VII. MODEL 1000 POWER UNIT (Continued...)

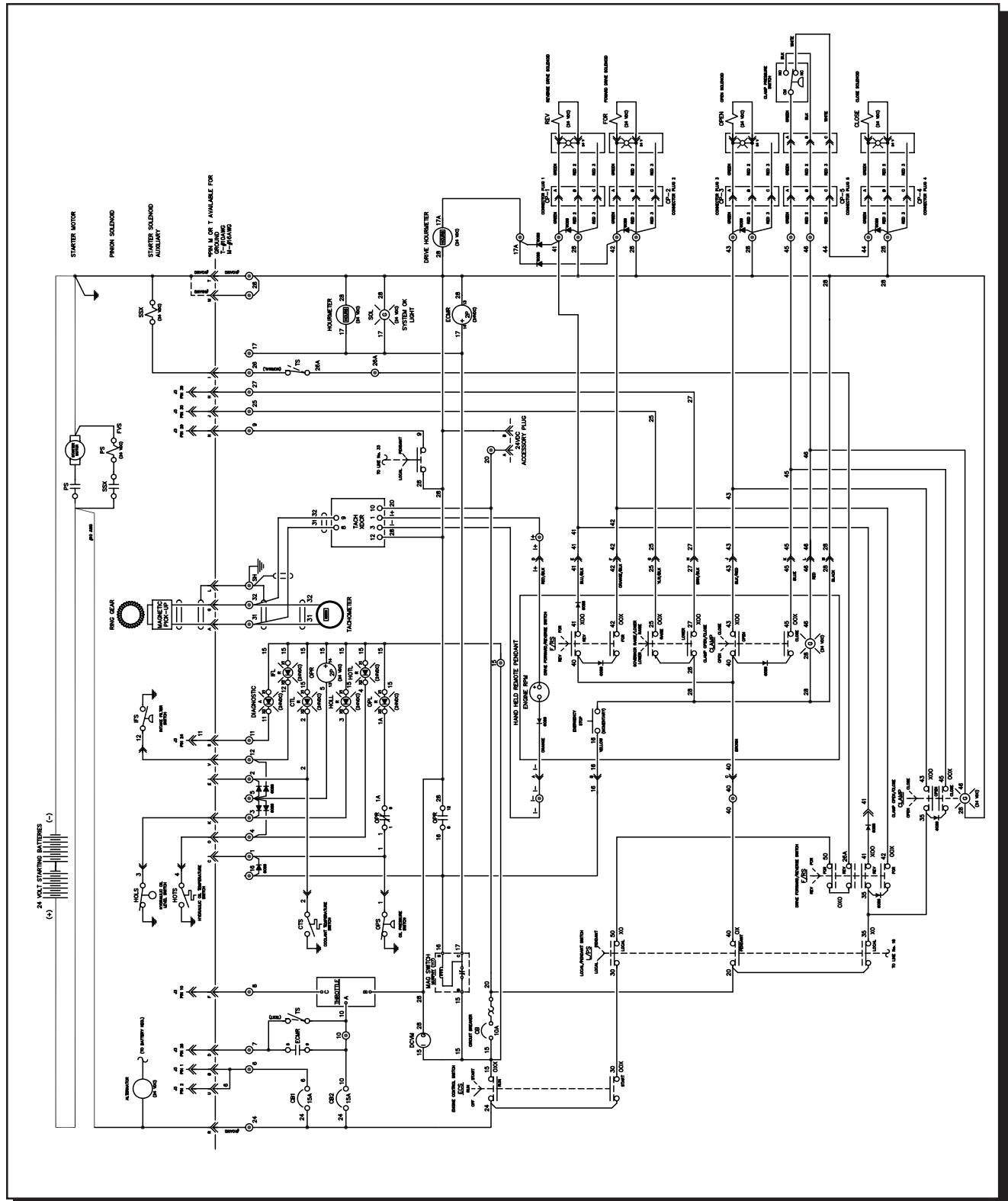

**Figure 7-T. Model 1000 Electrical Schematic**

# OPERATION / MAINTENANCE MANUAL

MODEL 400 TANDEM VIBRATORY HAMMER WITH  
MODEL 1000 POWER UNIT

7032 So. 196th - Kent, WA. 98032 - (253) 872-0141 / Fax (253) 872-8710

## VII. MODEL 1000 POWER UNIT (Continued...)

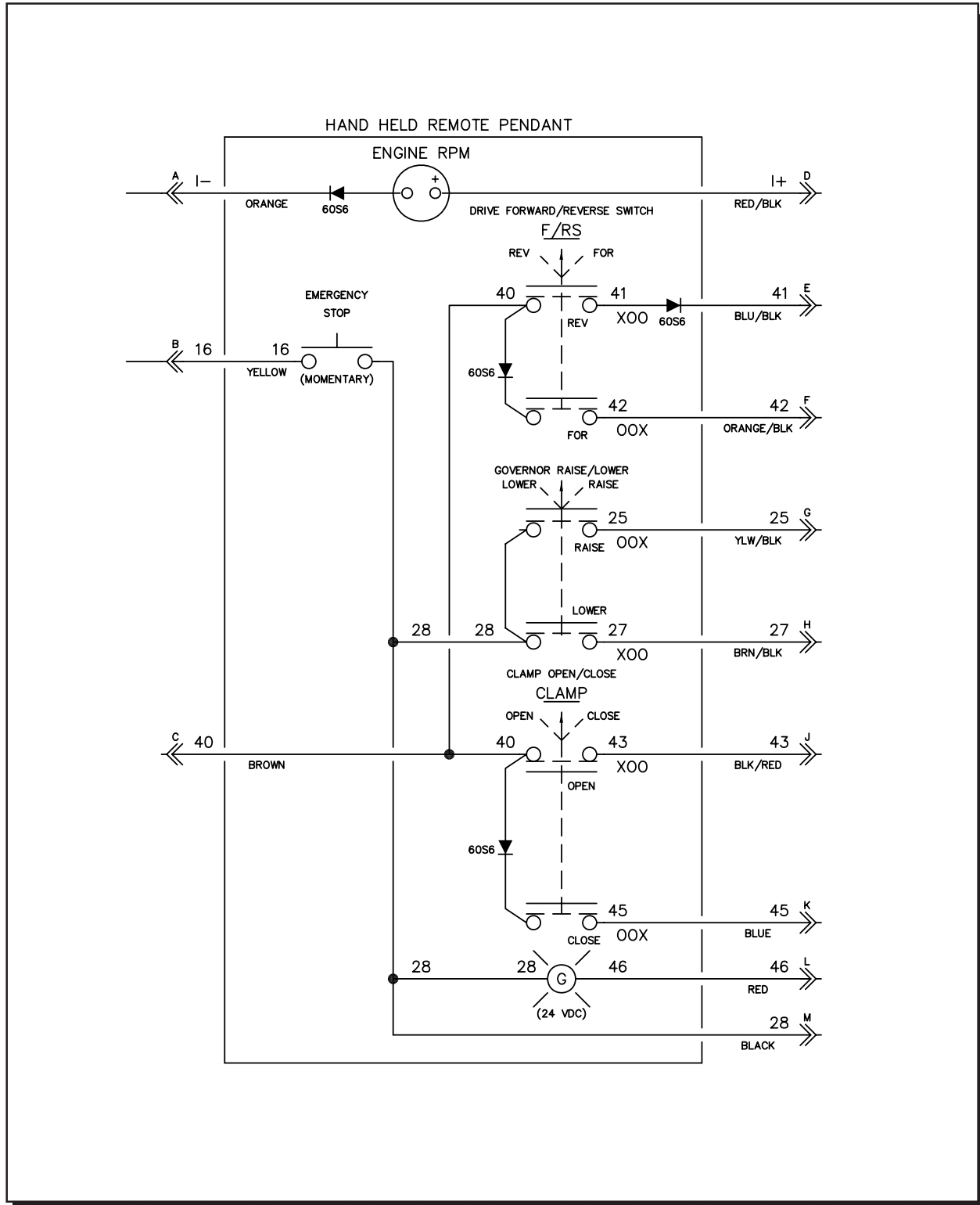

**Figure 7-U. Remote Pendant Electrical Schematic**



# **OPERATION / MAINTENANCE MANUAL**

**MODEL 400 TANDEM VIBRATORY HAMMER WITH  
MODEL 1000 POWER UNIT**

7032 So. 196th - Kent, WA. 98032 - (253) 872-0141 / Fax (253) 872-8710

## **- APPENDIX A -**

### **CAT 3412E Twin Turbo 1000 HP Engine**

#### **A-1. ENGINE OPERATION INSTRUCTIONS**

The following sections are basic instructions for maintenance and operation of the **Model 1000 Power Unit Engines**. All maintenance should be performed by qualified personnel who are familiar with the equipment. (Consult the factory for additional information.)

#### **A-1A. PRE-START INSPECTION AND PROCEDURES**

1. Make a "walk-around" inspection of the engine and components for the oil, water or fuel leaks and general appearance. Correct minor adjustments before they develop into major repair jobs.
2. Check the crankcase oil level. Maintain the oil level between the ADD and FULL marks on the dipstick. See OIL SPECIFICATIONS for type of oil to use.
3. Check oil level(s) on driven equipment.

**WARNING: Check the engine coolant level when the engine is cool. If the engine is warm, steam may spray outward under high pressure and cause personal injury.**

4. Check the engine jacket coolant level. Slowly turn the pressure cap until the cap is removed. Maintain coolant level to the base of the fill pipe.
5. Check the fuel supply. Keep fuel tanks full, as partially filled tanks will collect moisture. See the FUEL SPECIFICATIONS for type of fuel.

#### **KEEP THE FUEL SUPPLY CLEAN**

6. Open the raw water valve on the engine jacket heat exchanger system (if so equipped). Prime the raw water pump if the raw water system has been drained.
7. Reset shutoff devices. See the topic, ATTACHMENTS, Emergency Shutoff Devices and Alarms. If the engine is equipped with an air safety shutoff control, and was tripped to the shutoff position, reset the latch to the run position.
8. Open the fuel supply valve. If the engine has not run for some time it may be necessary to prime the system. See the topic, PRIMING THE FUEL SYSTEM.
9. Disconnect any battery charger which is not protected against starting motor drain.
10. Disengage the clutch, or open the circuit breaker on a generator set.



# **OPERATION / MAINTENANCE MANUAL**

**MODEL 400 TANDEM VIBRATORY HAMMER WITH  
MODEL 1000 POWER UNIT**

7032 So. 196th - Kent, WA. 98032 - (253) 872-0141 / Fax (253) 872-8710

## **- APPENDIX A -**

### **CAT 3412E Twin Turbo 1000 HP Engine**

#### **A-1B. STARTING THE ENGINE.**

**CAUTION: Do not engage the starter when the flywheel is moving.**

##### **Electric Starting**

1. Move the governor control lever to approximate half engine speed position.
2. Use starting aids if required.
3. Push the START button; or turn the HEAT START switch to the START position, depending upon the control the engine has. Release the control as soon as the engine starts.

For generator sets, place the AUTO-MAN switch in the MAN position to crank the engine. As soon as the engine starts, and the engine speed reaches 600 rpm and oil pressure is approximately 22 psi (1.5 kg /CM<sup>2</sup>), the starter motor will disconnect from the circuit. (The STOP position is used to stop the diesel engine.)

If the engine fails to start within 10 seconds, move the governor control lever to the fuel off position, then continue to crank for 10 seconds. This will clear the cylinders of unburned fuel.

If the engine fails to start after 30 seconds of cranking, allow the engine to cool for 2 minutes before repeating the starting procedure.

**CAUTION: Prolonged cranking at low oil pressure can activate the mechanical safety shut-off. If the reset lever is in the shut-off position, reset the mechanical shut-off control.**

**CAUTION: NEVER use starting aids when the engine is warm and running.**

##### **Air Starting**

1. Open and close the bleed valve on the bottom of the air tank to drain condensation and oil carryover.
2. Check the air supply pressure. The air start must have 100 PSI (7 kg/cm<sup>2</sup>) to operate properly.
3. Keep oil level, in the oiler jar, at least half full. Add oil if necessary.
4. Push the air valve control in to crank the engine. As soon as the engine starts, release the valve.



# **OPERATION / MAINTENANCE MANUAL**

**MODEL 400 TANDEM VIBRATORY HAMMER WITH  
MODEL 1000 POWER UNIT**

7032 So. 196th - Kent, WA. 98032 - (253) 872-0141 / Fax (253) 872-8710

## **- APPENDIX A -**

### **CAT 3412 Twin Turbo 1000 HP Engine**

#### **A-1. OPERATION INSTRUCTIONS. (Continued...)**

##### **A-1C. ENGINE OPERATION.**

After the engine starts, and at frequent intervals while the engine is operating, the gauges should be observed. Determine the normal reading for each gauge. Investigate the cause whenever there is a significant change in the reading.

##### **Tachometer**

The tachometer indicates engine RPM. The high idle RPM and the full load RPM are stamped on the engine's information plate. The engine can be operated between these two speed limits for long periods of time without shortening engine life. Prolonged operation at high idle with little or no load can cause adverse engine operation.

##### **Engine Oil Pressure**

If the gauge reading fluctuates after the load is stable:

1. Remove the load.
2. Reduce engine speed to low idle.
3. Observe the oil level. Maintain the oil level between the ADD and FULL mark on the dipstick. If the reading continues to fluctuate when the oil level is correct, stop engine and call your Caterpillar dealer.

##### **Engine Jacket Water Temperature**

The engine should operate within the NORMAL (green) range. If the engine is operating in the (red) range and steam becomes apparent:

1. Reduce the load and engine RPM.
2. Inspect for coolant leaks.
3. Determine if the engine must be shut down immediately; or if the engine can be safely cooled by reducing the load. (See COOLING SPECIFICATION INSTRUCTIONS.)

**CAUTION: Do not add cold water to a hot engine: Cracking of engine components may occur. Allow the engine to cool, then add coolant.**



# **OPERATION / MAINTENANCE MANUAL**

**MODEL 400 TANDEM VIBRATORY HAMMER WITH  
MODEL 1000 POWER UNIT**

7032 So. 196th - Kent, WA. 98032 - (253) 872-0141 / Fax (253) 872-8710

## **- APPENDIX A -**

### **CAT 3412 Twin Turbo 1000 HP Engine**

#### **A-1C. ENGINE OPERATION (Continued...)**

##### **Water Temperature Gauge**

If the temperature gauge reading registers in or near the cold range (white) while operating under load:

1. Check the water temperature gauge for accuracy.
2. Check the temperature regulators for proper temperature range. Replace regulators if necessary.

##### **Fuel pressure**

If the fuel filter gauge registers in the OUT range, clean the primary fuel filter, if so equipped. Install new secondary or final fuel filter elements if gauge still registers OUT. See the FUEL MAINTENANCE INSTRUCTIONS and FUEL SPECIFICATIONS.

##### **Ammeter:**

The ammeter reading is normal when the indicator is at or on the (+) side of zero, when the engine is running at rated speed. If indicator is to the left (-) side of zero, investigate and correct cause.

##### **Air Cleaner Service Indicator**

When the gauge indicator locks in the red range, service the air cleaner. With the engine stopped.

##### **Calibrated Gauges**

Calibrated gauges are used on some engines to monitor the engine systems. If an abnormal engine condition develops, determine and analyze and correct the cause before a failure and downtime occurs.

If any of the gauges register at or outside the operating limits, investigate and correct any malfunction. See TROUBLESHOOTING for guidance.

**WARNING: Shut the engine down if work on or around the engine is required.  
DO NOT OPERATE THE ENGINE WITH THE GAUGES REGISTERING AT OR OUTSIDE  
THE LIMITS.**





# **OPERATION / MAINTENANCE MANUAL**

**MODEL 400 TANDEM VIBRATORY HAMMER WITH  
MODEL 1000 POWER UNIT**

7032 So. 196th - Kent, WA. 98032 - (253) 872-0141 / Fax (253) 872-8710

## **- APPENDIX A -**

### **CAT 3412 Twin Turbo 1000 HP Engine**

#### **A-1C. ENGINE OPERATION (Continued...)**

##### **Altitude Operation**

The fuel system settings and altitude limits are stamped on the engine information plate. When an engine is moved to a higher altitude, these settings must be changed by your Caterpillar dealer in order to prevent damaging the turbocharger, and to provide maximum engine efficiency. If the engine is moved to a lower altitude than that which is stamped on the engine information plate, the engine can be operated safely; however, it will deliver less than rated horsepower, and the fuel settings should be changed by your Caterpillar dealer to obtain rated horsepower.

##### **Stopping**

1. Flywheel clutch operation: Quickly pull the clutch lever to the released position.
2. Reduce engine speed to half speed. Run for 5-10 minutes to cool engine.
3. Reduce engine speed to low idle.
4. Observe the crankcase oil level while the engine is idling. Maintain the oil level between the ADD and FULL marks on the side of the dipstick stamped, CHECK WITH ENGINE RUNNING. See the LUBRICATION AND MAINTENANCE SECTION.
5. Stop the engine.

##### **After Stopping Checks And Procedures**

1. Fill the fuel tank. See the LUBRICATION AND MAINTENANCE SECTION: Fuel Tank Maintenance.
2. Drain the raw water system if below freezing temperatures are expected; see: Draining Raw Water System.
3. If below freezing temperatures are expected, allow the engine jacket water expansion tank to cool, then check the coolant for proper antifreeze protection. Add permanent-type antifreeze, if required.
4. Repair any leaks, make minor adjustments, tighten loose bolts, etc.
5. Observe the Service Meter reading. Perform the periodic maintenance as instructed in the LUBRICATION AND MAINTENANCE CHART.



# **OPERATION / MAINTENANCE MANUAL**

**MODEL 400 TANDEM VIBRATORY HAMMER WITH  
MODEL 1000 POWER UNIT**

7032 So. 196th - Kent, WA. 98032 - (253) 872-0141 / Fax (253) 872-8710

## **- APPENDIX A - CAT 3412 Twin Turbo 1000 HP Engine**

### **Starting The Engine**

1. Perform all prestart checks outlined previously.
2. Place the CONTROL switch in the MANUAL position to crank the engine.
3. When the engine starts and engine rpm reaches 600 rpm and the oil pressure registers 22 psi (1.5 kg/cm<sup>2</sup>) the starting motor will automatically disconnect from the start circuit.
4. Start the load.
5. Regulate the engine speed with the RAISE LOWER switch to the required instrument panel gauge readings.

### **Stopping The Engine**

1. Remove the load.
2. Reduce engine speed to low idle: Push down and hold the RAISE-LOWER switch until the engine low idle speed is reached.
3. While the engine is idling, check the engine oil level. Oil level must be maintained between the ADD and FULL marks on the side of the dipstick marked "CHECK WITH ENGINE RUNNING".
4. Stop the engine.

#### **(Solenoid Shutoff)**

- a. Move the control switch to the STOP or OFF positions. (Do not confuse this with the "RAISE-LOWER" switch.)

#### **(PSG Governor:)**

- b. Move the shutoff lever forward, or hold the lever up, depending upon installation. Hold the lever in this position until the engine stops.

5. Fill the fuel tank. See the LUBRICATION AND MAINTENANCE section.
6. Drain the raw water system if below freezing temperatures are expected.

Observe the Service Meter reading. Perform the periodic maintenance as instructed in the LUBRICATION AND MAINTENANCE CHART.

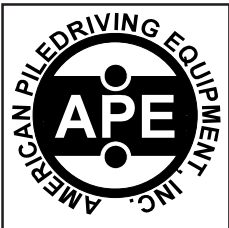

# **OPERATION / MAINTENANCE MANUAL**

**MODEL 400 TANDEM VIBRATORY HAMMER WITH  
MODEL 1000 POWER UNIT**

7032 So. 196th - Kent, WA. 98032 - (253) 872-0141 / Fax (253) 872-8710

## **- APPENDIX A -**

### **CAT 3412 Twin Turbo 1000 HP Engine**

#### **A-1D. Determining Cause Of Shutdown**

**CAUTION: If the engine has been shutdown by a safety device, don't start the engine and place it into service without having the cause of the shutdown investigated and corrected**

#### **Low Oil Pressure Checks**

If the low oil pressure shutoff control has stopped the engine, make the following checks:

1. Check the water temperature gauge. Determine if the engine was overheated. Check for external water leaks.

**WARNING: Beware of steam or scalding water. Do not attempt to loosen the radiator cap until the temperature gauge indicates the coolant has sufficiently cooled. Then, loosen the cap slowly.**

2. Check the oil level. Oil level must be between the ADD and FULL marks on the side of the dipstick stamped CHECK WITH ENGINE STOPPED.
3. If the oil level is below the ADD mark, check for oil spray and/or oil accumulations. If any are found, have the necessary repairs made. Before starting, add oil to the FULL mark.
4. Reset the shutoff control.
5. Remove the load and start the engine at its slowest speed. Be prepared to shut the engine down manually.
6. Be alert for unusual sounds or noises. If the engine knocks, stop the engine immediately and call your engine dealer.
7. If the engine blows excessive black exhaust or has excessive crankcase blow-by, the engine may need reconditioning. Stop the engine and call your engine dealer.
8. If the engine runs satisfactorily, observe the oil pressure gauge. If satisfactory pressure is not indicated, shut the engine down; call your engine dealer.
9. If proper oil pressure is registered, check to see if the reset knob has moved to the run position. If the knob does not move, stop the engine. Check the shutoff control, the oil line, and the oil pressure gauge. Have necessary repairs made.
10. If the oil pressure gauge registers normal oil pressure, if the knob on the shutoff control moves to the run position, and if the engine operation is otherwise satisfactory, determine if the high water temperature shutoff may have shut down the engine.



# **OPERATION / MAINTENANCE MANUAL**

**MODEL 400 TANDEM VIBRATORY HAMMER WITH  
MODEL 1000 POWER UNIT**

7032 So. 196th - Kent, WA. 98032 - (253) 872-0141 / Fax (253) 872-8710

## **- APPENDIX A -**

### **CAT 3412 Twin Turbo 1000 HP Engine**

#### **A-1D. Determining Cause Of Shutdown (Continued...)**

##### **High Water Temperature Checks-Engine Running**

1. Determine if the load was too great for the engine - Reduce the load and allow the engine to cool while running.
2. If pressure steam or water leaks are visible, remove the load and stop the engine. Have necessary repairs made.
3. Check for collapsing or deteriorated water hoses. Have repairs made.
4. Check for noisy water pump operation. Have necessary repairs made.
5. Refill the cooling system with a solution of water and permanent-type antifreeze if below freezing temperatures are expected; or with a solution of approved water and Corrosion Inhibitor. Follow the instructions on the container.

**WARNING: DO NOT remove the pressure cap on an overheated engine. The coolant is under pressure and relieving the pressure will cause the coolant to flash into steam.**

NOTE: If there is adequate coolant in the cooling system, gradual cooling is preferred by running the engine at half speed. This eliminates hot spots in the engine, and possible failure.

##### **High Water Temperature Checks-Engine Stopped and Cold**

1. Check coolant level. Determine if the coolant has proper antifreeze protection. A 50-50 solution of permanent-type antifreeze and approved water will give protection below -200F (-290C).
2. Check to be sure the raw water valve has been opened.
3. Check engine room vents and/or louvers. Be sure the engine is receiving sufficient air.
4. Be sure temperature regulators are operating at proper temperature range.
5. Inspect all water hoses carefully for collapsing, external and internal failures. Replace hoses as required.
6. Have the cooling system cleaned.

**CAUTION: If severe or prolonged overheating has occurred, contact your engine dealer to have your engine checked for possible damage.**



# **OPERATION / MAINTENANCE MANUAL**

**MODEL 400 TANDEM VIBRATORY HAMMER WITH  
MODEL 1000 POWER UNIT**

7032 So. 196th - Kent, WA. 98032 - (253) 872-0141 / Fax (253) 872-8710

## **- APPENDIX A -**

### **CAT 3412 Twin Turbo 1000 HP Engine**

#### **A-2. MAINTENANCE RECOMMENDATIONS**

**CAUTION: Never add coolant to an overheated engine; allow the engine to cool first.**

#### **Cooling**

Check specific gravity of antifreeze solution frequently in cold weather to assure adequate protection.

Coolant should be drained and replaced "Every 2000 Service Meter Units." With additions of Cooling System Inhibitor or the use of Coolant Conditioner Elements as recommended, the drain period can be extended to "Every 4000 Service Meter Units."

All water is corrosive at engine operating temperature. The cooling system should be protected with inhibitor at all times regardless of concentration of antifreeze. This can be done by maintaining a 3% concentration of liquid Cooling System Inhibitor or by using Coolant Conditioner Elements.

Never use both the liquid cooling system inhibitor and coolant elements at the same time.

Do not use Cooling System Inhibitor or Coolant Conditioner Elements with Dowtherm 209 Full-Fill Coolant.

Whenever draining and refilling cooling system, always recheck the coolant level when the engine reaches normal operating temperature.

Filling at over 5 U.S. gallons (19 liters) per minute can cause air pockets in the cooling system.

Premix antifreeze solution to provide protection to the lowest expected ambient temperature. Pure undiluted antifreeze will freeze at -100F (-23,C).

Operate with a thermostat in the cooling system all year-round. Cooling system problems can arise without a thermostat.

#### **Electrical**

**CAUTION: When using jumper cables to start the engine, be sure to connect in parallel: POSITIVE (+) to POSITIVE (+) and NEGATIVE (-) to NEGATIVE (-).**

#### **Scheduled Oil Sampling**

Use scheduled Oil sampling to monitor the engine's condition and maintenance requirements. Each oil sample should be taken when the oil is hot, and well mixed, to insure a sample which is representative of the oil in the compartment.

Consult your engine dealer for complete information, and assistance in establishing a Scheduled Oil Sampling program for your equipment.



# **OPERATION / MAINTENANCE MANUAL**

**MODEL 400 TANDEM VIBRATORY HAMMER WITH  
MODEL 1000 POWER UNIT**

7032 So. 196th - Kent, WA. 98032 - (253) 872-0141 / Fax (253) 872-8710

## **- APPENDIX A -** **CAT 3412 Twin Turbo 1000 HP Engine**

### **A-2. MAINTENANCE RECOMMENDATIONS (Continued...)**

#### **Fuel**

**CAUTION: Fill fuel tank at the end of each day of operation to drive out moisture-laden air and to prevent condensation. Do not fill the tank to the brim. The fuel expands when it gets warm and may overflow.**

Water and sediment should be drained from the fuel tank at the start of each shift or after the fuel tank has been filled and allowed to stand for 5 to 10 minutes.

Drain fuel tank of moisture and sediment as required by prevailing conditions.

After changing fuel filters, always bleed fuel system to remove air bubbles from system.

#### **Air intake**

Service air cleaners when RED band in indicator locks in visible position.

### **A-2A. LUBRICATION SPECIFICATIONS**

#### **Crankcase Lubricating Oils**

Use oils which meet Engine Service Classification (MIL-L-2104D) or CD/TO-2. These are additive-type oils that have been approved for use in Diesel Engines.

Consult the "EMA Lubricating Oils Data Book," Form SEBU5939, for a listing of CD oil brands.

The proper SAE grade of oil to select is determined by the ambient temperature at which the engine is started and the maximum ambient temperature in which the engine will be operating.

To determine if the oil in the crankcase will flow in cold weather, remove the oil dipstick before starting. If the oil will flow off, the oil is fluid enough to circulate properly.

#### **Lubricating Grease**

Use Multipurpose-type Grease (MPGM) which contains 3-5% molybdenum disulfide conforming to MIL-M-7866, and a suitable corrosion inhibitor. NLGI No.2 Grade is suitable for most temperatures. Use NLGI No. 0 or No. 1 Grade for extremely low temperatures.

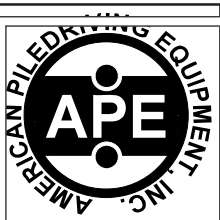

# **OPERATION / MAINTENANCE MANUAL**

**MODEL 400 TANDEM VIBRATORY HAMMER WITH  
MODEL 1000 POWER UNIT**

7032 So. 196th - Kent, WA. 98032 - (253) 872-0141 / Fax (253) 872-8710

## **- APPENDIX A -**

### **CAT 3412 Twin Turbo 1000 HP Engine**

#### **A-2. MAINTENANCE RECOMMENDATIONS (Continued...)**

##### **A-2B. FUEL SPECIFICATIONS**

No. 2 fuel oil and No. 2D diesel fuel are recommended for use in Diesel Engines. In extreme cold temperatures use No. 1 fuel oil or No.1 D diesel fuel.

In selecting a fuel, note that distillate fuels are especially desirable because the fuel is heated to a vaporous state and condensed, thus eliminating all sediment and residue.

##### **A-2C. COOLANT SPECIFICATIONS**

Water used in the jacket water cooling system should be clean, and as free as possible from scale forming minerals or corrosive chemicals. Artificially softened water should not be used. Treating the water with Coolant Inhibitor, or equivalent will help prevent the formation of rust and pitting. It will also retard, and in some cases completely eliminate, mineral deposits in the engine.

The most efficient and satisfactory corrosion protection for the cooling system is to maintain proper level of coolant inhibitor and antifreeze solution. The use of auxiliary water filters is not recommended.

During freezing weather use the proper permanent type antifreeze and water solution to prevent freezing.

Before placing the engine in operation, make sure a 3% concentration of Corrosion Inhibitor has been added to the cooling system. This 3% concentration must be maintained in cooling systems which are filled with water and systems protected with ethylene glycol antifreeze mixture, regardless of antifreeze concentration.

**WARNING: Inhibitors contain alkali. Avoid contact with eyes. To prevent personal injury, avoid prolonged or repeated contact with skin.**



# OPERATION / MAINTENANCE MANUAL

MODEL 400 TANDEM VIBRATORY HAMMER WITH  
MODEL 1000 POWER UNIT

7032 So. 196th - Kent, WA. 98032 - (253) 872-0141 / Fax (253) 872-8710

## - APPENDIX A - CAT 3412 Twin Turbo 1000 HP Engine

### A-2. MAINTENANCE RECOMMENDATIONS (Continued...)

#### A-2D. LUBRICATION AND MAINTENANCE

The LUBRICATION AND MAINTENANCE CHART lists all serviceable items commonly ordered on this engine. The maintenance tune intervals are expressed in "Operating Hours".

Daily	Weekly	250 Hours or 6 months	1500 Hours or 1 Year	6000 Hours or 2 Years	6000 Hours or 3 Years
<ul style="list-style-type: none"> <li>• Check operator's report</li> <li>• Check and bring to correct level               <ul style="list-style-type: none"> <li>- Engine Oil</li> <li>- Coolant</li> </ul> </li> <li>• Visually inspect fan.</li> <li>• Visually inspect engine for damage, leaks, loose or frayed belts and correct or record for future action.</li> <li>• Drain fuel-water separator.</li> </ul>	<p><b>Repeat Daily Check</b></p> <ul style="list-style-type: none"> <li>• Check air intake system for wear points or damage to piping, loose clamps, and leaks.</li> <li>• Check air cleaner restriction.</li> <li>• Check and clean air cleaner element.</li> <li>• Drain moisture from air tanks.</li> </ul>	<p><b>Repeat Daily and Weekly Check</b></p> <ul style="list-style-type: none"> <li>• Change Lubricating Oil.</li> <li>• Change Lubricating Oil Filters.</li> <li>• Change Fuel Filter.</li> <li>• Change Coolant Filter.</li> <li>• Clean Crankcase Breather.</li> <li>• Check engine coolant concentration level. Add make-up if required.</li> <li>• Replace final Fuel Filter/Clean primary Fuel Filter. Drain water from fuel tank.</li> <li>• Inspect/Replace Alternator, Fan and Accessory Drive Belts.</li> <li>• Inspect/Replace Hoses and Clamps.</li> <li>• Lubricate Fan Drive Bearings.</li> <li>• Clean/Check Battery electrolyte level.</li> </ul>	<p><b>Repeat Previous Intervals</b></p> <ul style="list-style-type: none"> <li>• Adjust valves and injectors.</li> <li>• Steam clean engine.</li> <li>• Check torque on turbocharger mounting nuts.</li> <li>• Check torque on engine mounting bolts</li> <li>• Replace hoses as required.</li> <li>• Check/Adjust engine valve lash.</li> <li>• Check/Adjust low idle speed.</li> <li>• Test/Exchange fuel injection nozzles.</li> <li>• Inspect coolant pump. Clean cooling system. (Internal)</li> <li>• Inspect/Rebuild Alternator.</li> </ul>	<p><b>Repeat Previous Intervals</b></p> <ul style="list-style-type: none"> <li>• Clean cooling system and change coolant and antifreeze.</li> <li>• Inspect temperature regulator.</li> <li>• Inspect/Rebuild turbocharger.</li> <li>• Inspect/Rebuild starter.</li> <li>• Check and adjust clutch.</li> </ul>	<p><b>Repeat Previous Intervals Which Are Due</b></p> <ul style="list-style-type: none"> <li>• Clean and calibrate the following: (Rebuild or exchange if required.)               <ul style="list-style-type: none"> <li>- Injectors.</li> <li>- Fuel pump.</li> <li>- Air compressor.</li> <li>- Fan clutch.</li> <li>- Water pump.</li> <li>- Fan hub.</li> <li>- Fan idler pulley assembly.</li> <li>- Vibration damper.</li> </ul> </li> </ul>

Follow the manufacturer's recommended maintenance procedures for the starter, alternator, generator, batteries, electrical components, engine brake, exhaust brake, air compressor, freon compressor, and fan clutch.  
At each scheduled maintenance interval, perform all previous maintenance checks which are due for scheduled maintenance.





# **OPERATION / MAINTENANCE MANUAL**

**MODEL 400 TANDEM VIBRATORY HAMMER WITH  
MODEL 1000 POWER UNIT**

7032 So. 196th - Kent, WA. 98032 - (253) 872-0141 / Fax (253) 872-8710

## **- APPENDIX A -**

### **CAT 3412 Twin Turbo 1000 HP Engine**

#### **A-2E. ELECTRICAL SYSTEM**

The following topics describe care and maintenance of the electrical system components. These components functioning together produce the energy needed for operating the electrical equipment on the engine and each is dependent upon the others for satisfactory operation. In the event of failure or improper operation, it is essential to check the entire electrical system as a defect in one component can cause damage to another. Many electrical system problems can be traced to loose or corroded connections. Keep connections tight and make sure the wiring insulation is in satisfactory condition. Most of the electrical system testing can be performed while the components are on the engine. It should be remembered, if a malfunction is found on test, the component must be removed for further testing, repair or replacement.

#### **Battery**

Every 250 hours check the electrolyte level of each cell and the general condition of the battery. Maintain the electrolyte level to the base of each vent well. The make-up water must be one of the following (in order of preference):

1. Distilled water.
2. Odorless, tasteless drinking water-
3. Iron free water.

**WARNING: Never add acid or electrolyte.**

#### **Cleaning Battery**

Mix a weak solution of baking soda and water. Apply the solution with a soft bristle brush. Be careful not to get cleaning solution into the battery. Thoroughly rinse the battery and battery tray with clean water. Apply grease to battery cable clamps and terminals and to all threads.

#### **Installing Battery**

1. Be sure the battery tray is clean and free of foreign objects.
2. Be sure terminal posts and cable clamps are clean.
3. Place the battery in the tray. Tighten the hold down clamps evenly until the battery is snug. Do not over tighten.
4. Connect the "hot" terminal first. Be sure the top of the cable terminal is pushed down even with the top of the terminal post. Tighten the clamp firmly.

**WARNING: Always connect the "hot" terminal first to minimize arcing. Otherwise injury or damage could result.**

5. Connect the "grounded" terminal last. Be sure the top of the cable terminal is pushed down even with the top of the terminal post. Tighten the clamp firmly.
6. Apply a thin coating of grease over the cable clamps, terminals and hold down fasteners.



# **OPERATION / MAINTENANCE MANUAL**

**MODEL 400 TANDEM VIBRATORY HAMMER WITH  
MODEL 1000 POWER UNIT**

7032 So. 196th - Kent, WA. 98032 - (253) 872-0141 / Fax (253) 872-8710

## **- APPENDIX A -**

### **CAT 3412 Twin Turbo 1000 HP Engine**

#### **A-2E. ELECTRICAL SYSTEM (Continued...)**

##### **Charging the Battery**

**WARNING: Never smoke in the area where batteries are being charged. Hydrogen gas is given off at each vent cap during charging. Hydrogen mixed with air is highly explosive.**

1. Connect positive charger clamp to positive battery terminal.
2. Connect negative charger clamp to negative battery terminal.
3. Connect charger power cord to proper outlet.
4. Allow battery to charge slowly.

**CAUTION: If battery is charged too rapidly, the battery will be damaged.**

5. After the battery is charged, disconnect charger power cord from outlet; remove charger clamp from negative battery terminal; remove charger clamp from positive battery terminal.

#### **A-3. Engine Troubleshooting.**

##### **-TROUBLESHOOTING INDEX-**

<b>ITEM</b>	<b>PROBLEM</b>	<b>ITEM</b>	<b>PROBLEM</b>
1.	Engine Fails to Start	15.	Valve Lash Close-up
2.	Misfiring	16.	Premature Engine Wear
3.	Erratic Engine Speed	17.	Coolant in Engine Lubricating Oil
4.	Low Power	18.	Excessive Black or Gray Smoke
5.	Excessive Vibration	19.	Excessive White or Blue Smoke
6.	Heavy Combustion Knock	20.	Low Engine Oil Pressure
7.	Valve Train Clicking Knock	21.	High Lubricating Oil Consumption
8.	Oil in Coolant	22.	Abnormal Engine Coolant Temperature
9.	Mechanical Knock	23.	Starting Motor Fails to Crank
10.	Excessive Fuel Consumption	24.	Alternator Fails to Charge
11.	Loud Valve Train Noise	25.	Alternator Charging Rate Low or Unsteady
12.	Excessive Valve Lash	26.	Alternator Charging Rate High
13.	Valve Spring Retainer Free	27.	Alternator Noisy
14.	Slobber	28.	Stalls at Low Speed



# OPERATION / MAINTENANCE MANUAL

MODEL 400 TANDEM VIBRATORY HAMMER WITH  
MODEL 1000 POWER UNIT

7032 So. 196th - Kent, WA. 98032 - (253) 872-0141 / Fax (253) 872-8710

## - APPENDIX A -

### CAT 3412 Twin Turbo 1000 HP Engine

#### A-3. Engine Troubleshooting. (Continued...)

Possible Causes	Remedy
<b>1. ENGINE FAILS TO START</b>	
No Fuel to Engine	Check for empty fuel tank, plugged fuel tank connections, obstructed or kinked fuel suction lines, fuel transfer pump failure, or plugged fuel filters.
Shutoff Solenoid Sticking*	Solenoid must be energized to shut off engine. Actuate the control that operates the shutoff solenoid and listen for a clicking sound. If clicking sound is not evident and engine will not start, remove the solenoid. Again try to start the engine. If the engine starts, the solenoid is bad. Replace the solenoid.
Fuel Transfer Pump	At cranking speed, the fuel transfer pump should supply fuel to the engine at 3 PSI (20 kPa). If fuel pressure is less than 3 PSI (20 kPa), replace the fuel filter. Check for air in fuel system, sticking, binding or defective fuel bypass valve. If pressure is still low, replace the fuel transfer pump.
Engine Improperly Timed	See your authorized dealer.
Glow Plug Failure	Check glow plugs.
Automatic and Safety Shutoff Controls	Check shutoff controls to ensure they are set properly. See Starting Procedures.
*Optional Equipment	
<b>2. MISFIRING</b>	
Defective Fuel Injection Nozzle or Fuel Pump	Run the engine at the speed where the defect is most pronounced. Momentarily loosen the fuel line nut on the injection pump to "cut out" that cylinder. Check each cylinder in this manner. If one is found where loosening makes no difference in irregular operation, the pump and nozzle for only that cylinder need be treated.
Improper Valve Lash	Set to specified clearance.
Incorrect Fuel Injection Timing	See your authorized dealer.
Low Fuel Supply Pressure	Check fuel supply line for leaks or kinks, air in fuel system, sticking, binding, or defective fuel bypass valve. Replace fuel filter. Check fuel pressure. Fuel transfer pump should supply fuel at 20 to 30 PSI (1.4 to 2.1 kg/cm <sup>2</sup> ) to the engine when the engine is fully loaded.
Broken or Leaking High Pressure Fuel Line	Replace the line.
Air in Fuel System	Find source of air entry and correct. Bleed system.
Bent or Broken Push Rod	Replace push rod.



# **OPERATION / MAINTENANCE MANUAL**

## **MODEL 400 TANDEM VIBRATORY HAMMER WITH MODEL 1000 POWER UNIT**

7032 So. 196th - Kent, WA. 98032 - (253) 872-0141 / Fax (253) 872-8710

### **- APPENDIX A -**

### **CAT 3412 Twin Turbo 1000 HP Engine**

#### **A-3. Engine Troubleshooting. (Continued...)**

<b>Possible Causes</b>	<b>Remedy</b>
<b>3. ERRATIC ENGINE SPEED</b>	
Governor Control Linkage	Adjust external linkage to obtain sufficient travel. Replace if damaged, bent, or linkage is too short.
Governor Failure	Look for damaged or broken springs, linkage, or other components. Determine if the rack can be moved manually. If any distress is noted in any of these components, replace as necessary.*
<b>4. LOW POWER</b>	
Fuel Nozzle Failure	Run the engine at the speed where the defect is most pronounced. Momentarily loosen the fuel line nut on the injection pump to "cut out" that cylinder. Check each cylinder in this manner. If one is found where loosening makes no difference in irregular operation, the pump and nozzle for only that cylinder need be tested.
Poor Quality Fuel	Drain, clean and bleed fuel system. Replace fuel filter. Fill fuel tank with proper grade of fuel.
Turbocharger Carboned or Otherwise Dragging	Inspect and repair or replace turbo charger as necessary.*
Leaks in Air Induction System	Check inlet manifold pressure. Check air cleaner for restriction.
Incorrect Fuel Injection Timing	See your authorized dealer.
Excessive Valve Lash	Set to specified clearance.
Low Fuel Supply Pressure	Check fuel supply line for leaks or kinks, air in fuel system, sticking, binding or defective fuel bypass valve. Replace fuel filter. Check fuel pressure. Fuel transfer pump should supply fuel to 20 to 30 PSI(1.4 to 2.1kg/CM2) to the engine when the engine is fully loaded.
<b>5. EXCESSIVE VIBRATION</b>	
Loose, Worn or Defective Engine Mounts as necessary.	Tighten all mounting bolts securely. Replace components
Loose Pulley and Damper	
Loose or Worn Coupling on Driven Equipment	Inspect, align and tighten coupling to driven equipment.
Defective Damper or Pulley	Replace damper or pulley.
Misfiring	See ITEM 2.



# **OPERATION / MAINTENANCE MANUAL**

**MODEL 400 TANDEM VIBRATORY HAMMER WITH  
MODEL 1000 POWER UNIT**

7032 So. 196th - Kent, WA. 98032 - (253) 872-0141 / Fax (253) 872-8710

## **- APPENDIX A -**

### **CAT 3412 Twin Turbo 1000 HP Engine**

#### **A-3. Engine Troubleshooting. (Continued...)**

<b>Possible Causes</b>	<b>Remedy</b>
<b>6. HEAVY COMBUSTION KNOCK</b>	
Air in Fuel System	Bleed air from system.
Defective Fuel Injection Pump Plunger and Barrel Assembly	Replace.*
Defective Fuel Injection Nozzle	Replace.
Incorrect Fuel Injection Timing	See your authorized dealer.*
<b>7. VALVE TRAIN CLICKING NOISE</b>	
Excessive Valve Lash	Set to specified clearance.
Broken Valve Spring(s)	Replace valve spring(s) and all other damaged components.*
Insufficient Lubrication	Check lubrication in valve compartment. Should be very wet at all speeds. Oil passages should be cleaned, especially those leading to the cylinder head.
<b>8. OIL IN COOLANT</b>	
Failed Oil Cooler Core	Replace oil cooler core.
Failed Head or Spacer Plate Gaskets	Replace head and spacer plate gaskets.
Cracked or Defective Cylinder Block	Replace cylinder block.*
Cracked or Defective Head	Replace cylinder head.
<b>9. MECHANICAL KNOCK</b>	
Engine Connecting Rod Bearing Failure	Replace the bearing. Check the connecting rod and crankshaft. Replace if necessary.*
Main Bearing Failure	Replace bearings.*
Damaged Timing Gear Train	Replace components as necessary.*
Broken Crankshaft	Replace crankshaft.*
Fuel Dilution of Crankcase Oil	Correct fuel leakage into crankcase oil.

\*Authorized dealers are equipped with the necessary tools and personnel familiar with disassembly procedures to perform these services.



# OPERATION / MAINTENANCE MANUAL

MODEL 400 TANDEM VIBRATORY HAMMER WITH  
MODEL 1000 POWER UNIT

7032 So. 196th - Kent, WA. 98032 - (253) 872-0141 / Fax (253) 872-8710

## - APPENDIX A -

### CAT 3412 Twin Turbo 1000 HP Engine

#### A-3. Engine Troubleshooting. (Continued...)

Possible Causes	Remedy
<b>10. EXCESSIVE FUEL CONSUMPTION</b>	
Fuel System Leaks	Large changes in fuel consumption may result. Internal leaks will probably be accompanied by low engine oil pressure and increased oil level in the engine oil sump. Replace leaking components.
Fuel and Combustion Knock	Small but measurable increases in fuel consumption maybe the result of defective fuel nozzles, misfiring or factors contributing to loss of power. See ITEM 2 and ITEM 5.
Incorrect Fuel Injection Timing	See your authorized dealer.
<b>11. LOUD VALVE TRAIN NOISE</b>	
Bent or Broken Valves	Replace damaged parts.*
Broken Camshaft	Replace all damaged parts. Clean engine thoroughly.
Broken or Severely Worn Valve Lifters	Replace camshaft and valve lifters. Check for sticking valves and bent valve stems. Clean engine thoroughly. Set valve lash to specified clearance.
<b>12. EXCESSIVE VALVE LASH</b>	
Severely Worn Cam Lobes	Check valve lash. Replace camshaft and followers. Clean engine thoroughly. Set valve lash to specified clearance.
Broken or Severely Worn Valve Lifters	Replace valve lifters. Check camshaft for wear. Check for sticking valves and bent valve stems. Clean engine thoroughly. Set valve lash to specified clearance.
Valve Tip Wear	Set valve lash to specified clearance. If wear is excessive, replace valve.
Moderate Valve Lifter Face Wear	Set valve lash to specified clearance. If wear is excessive, replace valve lifter.
Push Rod Wear	Set valve lash to specified clearance. If wear is excessive, replace push rod.
Rocker Arm Anvil Wear	Set valve lash to specified clearance. If wear is excessive, replace rocker arm.
Insufficient Lubrication	Check lubrication in valve should be very wet at high idle speeds, but only damp at low idle. Oil passages should be cleaned, especially those leading to the cylinder head.



# **OPERATION / MAINTENANCE MANUAL**

**MODEL 400 TANDEM VIBRATORY HAMMER WITH  
MODEL 1000 POWER UNIT**

7032 So. 196th - Kent, WA. 98032 - (253) 872-0141 / Fax (253) 872-8710

## **- APPENDIX A -**

### **CAT 3412 Twin Turbo 1000 HP Engine**

#### **A-3. Engine Troubleshooting. (Continued...)**

<b>Possible Causes</b>	<b>Remedy</b>
<b>13. VALVE SPRING RETAINER FREE</b>	
Broken Keepers	Extensive engine damage may result from dropped valve. Replace all damaged parts.*
Broken Valve Spring	Replace valve spring.*
Broken Valve	Replace valve and any other damaged parts.*
<b>14. SLOBBER</b>	
Excessive Valve Guide Wear	Recondition cylinder head assembly.*
Excessive Lubricating Oil in Valve Compartment in place.	Check rocker arm shaft and plugs to assure that they are in place.
Worn Piston Rings and/or Liners	Inspect and replace components as necessary.*
<b>15. VALVE LASH CLOSE-UP</b>	
Valve Face and/or Seat Wear	Adjust valves to specified clearance. Recondition cylinder head.
<b>16. PREMATURE ENGINE WEAR</b>	
Intake Piping Failure (Air Cleaner)	Inspect all gaskets and piping for leaks. Repair all leaks.
Excessive Fuel Dilution of Lubricating Oil	Replace leaking components. This will probably be ac- companied by high fuel consumption and low engine oil pressure. Tighten fuel injection line fittings under valve cover.
Dirt in Lubricating Oil	Locate and correct source of dirt entry, Change lubricating oil. Change oil filter.
<b>17. COOLANT IN ENGINE LUBRICATING OIL</b>	
Oil Cooler Failure	Replace oil cooler core.
Cylinder Head Gasket Failure	Replace gasket. Maintain proper torque on cylinder head bolts.
Cracked or Defective Cylinder Head	Replace cylinder head.*
Cracked or Defective Cylinder Block	Replace cylinder block.*

\*Authorized dealers are equipped with the necessary tools and personnel familiar with disassembly and assembly procedures to perform these serviced.



# **OPERATION / MAINTENANCE MANUAL**

**MODEL 400 TANDEM VIBRATORY HAMMER WITH  
MODEL 1000 POWER UNIT**

7032 So. 196th - Kent, WA. 98032 - (253) 872-0141 / Fax (253) 872-8710

## **- APPENDIX A -**

### **CAT 3412 Twin Turbo 1000 HP Engine**

#### **A-3. Engine Troubleshooting. (Continued...)**

<b>Possible Causes</b>	<b>Remedy</b>
<b>17. COOLANT IN ENGINE LUBRICATING OIL (Cont'd)</b>	
Cylinder Liner Seal Leaking	Replace seals.*
Cracked or Defective Cylinder Liners	Replace cylinder liners.'
<b>18. EXCESSIVE BLACK OR GRAY SMOKE</b>	
Insufficient Combustion Air	Check air cleaner for restriction. Check inlet manifold pressure. Inspect turbocharger for proper operation.
Fuel Nozzle Plugged or Leaking	Replace nozzle.
Incorrect Fuel Injection Timing	See your authorized dealer.
Fuel Ratio Control Improperly Adjusted	Adjust fuel ratio control.*
<b>19. EXCESSIVE WHITE OR BLUE SMOKE</b>	
Valve Guides Worn	Recondition cylinder head assembly.*
Piston Rings Worn, Stuck or Broken	Replace.*
High Crankcase Oil Level	Avoid overfilling. Determine cause and drain excess oil.
Misfiring	See ITEM 2.
Fuel Injection Pump Timing Wrong	See your authorized dealer.
Air in Fuel System	Bleed fuel system.
<b>20. LOW ENGINE OIL PRESSURE</b>	
Engine Oil Diluted with Fuel Oil	Check lip-type seal on fuel transfer pump drive shaft. Drain crankcase and refill with clean lubricant.
Excessive Crankshaft Bearing Clearance	Replace bearings and/or crankshaft.* Check oil filter operation.
Excessive Timing Gear Bearing Clearances	Inspect bearings and replace components as necessary.
Excessive Rocker Arm Bore or Rocker Arm Shaft Wear	Check lubrication. Replace components as necessary.
Defective Oil Pump	Repair or replace.*
	Replace.





# **OPERATION / MAINTENANCE MANUAL**

**MODEL 400 TANDEM VIBRATORY HAMMER WITH  
MODEL 1000 POWER UNIT**

7032 So. 196th - Kent, WA. 98032 - (253) 872-0141 / Fax (253) 872-8710

## **- APPENDIX A -**

### **CAT 3412 Twin Turbo 1000 HP Engine**

#### **A-3. Engine Troubleshooting. (Continued...)**

<b>Possible Causes</b>	<b>Remedy</b>
<b>20. LOW ENGINE OIL PRESSURE (Cont'd)</b>	
Clogged Oil Filter or Cooler	Repair or replace as necessary.
Oil Pump Relief Valve Stuck	Clean valve and housing. Replace if necessary.
<b>21. HIGH LUBRICATING OIL CONSUMPTION</b>	
Oil Leaks	Replace gaskets or seals and tighten all connections.
Excessive Oil to Intake	See ITEM 15. Valve Guides.
Excessive Valve Guide Wear	See ITEM 15.
Crankcase Oil Level Too High	Avoid overfilling. Determine cause and drain excess oil.
High Oil Temperature	Check oil cooler bypass valve. Replace if defective. Clean oil cooler core.
Worn Piston Rings and/or Liner	Replace components as necessary.*
<b>22. ABNORMAL ENGINE COOLANT TEMPERATURE</b>	
Combustion Gases in Coolant	Determine point at which gases enter the system. Repair or replace components as necessary.
Defective Water Temperature Regulator or Temperature Gauge	Check temperature regulator for proper opening temperature and correct installation. Check temperature gauge. Replace if necessary.
Coolant Level Low	Determine cause-replace leaking gaskets and hoses. Tighten connections. Add coolant.
Air Flow Through Radiator Restricted	Remove all debris from outer surface of radiator.
Defective Water Pump	Check water pump impeller. Repair water pump as necessary.
Radiator Small for Engine Application	Install correct size radiator.
Fan Improperly Positioned in Shroud or Not Shrouded	Position fan correctly.*

\*Authorized dealers are equipped with the necessary tools and personnel familiar with disassembly and assembly procedures to perform these serviced.



# **OPERATION / MAINTENANCE MANUAL**

**MODEL 400 TANDEM VIBRATORY HAMMER WITH  
MODEL 1000 POWER UNIT**

7032 So. 196th - Kent, WA. 98032 - (253) 872-0141 / Fax (253) 872-8710

## **- APPENDIX A -**

### **CAT 3412 Twin Turbo 1000 HP Engine**

#### **A-3. Engine Troubleshooting. (Continued...)**

**Possible Causes**

**Remedy**

#### **22. ABNORMAL ENGINE COOLANT TEMPERATURE**

Incorrect Fuel Injection Timing	See your authorized dealer.
Incorrect Water Piping Connections from Engine to Radiator	Check shunt line (if equipped) and vent line for correct installation.

#### **23. STARTING MOTOR FAILS TO CRANK**

Low Output from Battery	Check battery and charge or replace.
Defective Wiring or Switch	Repair or replace.
Defective Solenoid	Replace.
Defective Starting Motor	Repair.

#### **24. ALTERNATOR FAILS TO CHARGE**

Drive Belt Loose	Adjust belt.
Open or High Resistance in Charging or Ground Return Circuits or Battery Connections	Inspect all cables and connectors. Clean, re tighten or replace defective parts.
Excessively Worn, Open or Defective Brushes	Replace brush assembly.*
Open Rotor Field Coil	Replace rotor assembly.*

#### **25. ALTERNATOR CHARGING RATE LOW OR UNSTEADY**

Drive Belt Loose	Adjust belt.
Intermittent or High Resistance in Charging or Ground Return Circuits or Battery Connections	Inspect all cables and connectors. Clean, re tighten or replace defective parts.
Excessively Worn, Sticky, or Defective Brushes	Replace brush assembly.*
Faulty Regulator	Replace regulator.*
Shorted or Open Rectifier Diodes	Replace defective rectifier diode assembly in alternator.*
Open Rotor	Replace rotor assembly.*



# **OPERATION / MAINTENANCE MANUAL**

**MODEL 400 TANDEM VIBRATORY HAMMER WITH  
MODEL 1000 POWER UNIT**

7032 So. 196th - Kent, WA. 98032 - (253) 872-0141 / Fax (253) 872-8710

## **- APPENDIX A -**

### **CAT 3412 Twin Turbo 1000 HP Engine**

#### **A-3. Engine Troubleshooting. (Continued...)**

<b>Possible Causes</b>	<b>Remedy</b>
<b>26. ALTERNATOR CHARGING RATE HIGH</b>	
Loose Connections	Tighten connections to alternator and regulator.
Defective Regulator	Replace regulator.
<b>27. ALTERNATOR NOISY</b>	
Defective Drive Belt	Replace belt.
Misaligned Belt or Pulley	Align drive pulley, alternator pulley and belt.
Loose Pulley	Tighten pulley nut. If keyway is worn, install a new pulley.
Worn Bearings	Replace bearings.
Shorted Rectifiers in Alternator	Replace diode assembly.*
Armature or Rotor Shaft Bent	Replace component.*
*Authorized dealers are equipped with the necessary tools and personnel familiar with disassembly and assembly procedures to perform these serviced.	
<b>28. STALLS AT LOW SPEED</b>	
Idle Speed Too Low	See your authorized dealer
Low Fuel Supply Pressure	Check fuel supply line for leaks or kinks, air in fuel system, sticking, binding, or defective fuel bypass valve. Replace fuel filter. Check fuel pressure. Fuel transfer pump should supply fuel at 20 to 30 PSI to the engine when the engine is fully loaded.
Defective Fuel Nozzle	Replace nozzle
Defective or Damaged Fuel Injection Pumps	Replace damaged or defective parts.
High Parasitic Loads	Check for excessive loading due to auxiliary attachments