



APE AUGER OWNER'S MANUAL

APE 50/75/80 AUGER



800-248-8498

WWW.APEVIBRO.COM



Page Left Intentionally Blank

Quick Reference Guide

This Quick Reference Guide will assist you in finding the information you're looking for.

GENERAL INFORMATION

TROUBLE SHOOTING

MAINTENANCE

REPLACEMENT PARTS

REFERENCE / NOTES

A Table of Contents is included after the Foreword.

Description:

50/75/80 BB AUGER

(These precautions must be followed at all times to ensure personal and equipment safety.)

DANGER

DANGER indicates a hazardous situation which, if not avoided, will result in death or serious injury.

WARNING

WARNING indicates a hazardous situation which, if not avoided, could result in death or serious injury.

NOTICE

NOTICE is used to address practices not related to personal injury

NOTE

- *NOTE indicates information that may help or guide you in the operation or service of the equipment.*

DISCLAIMER:

This unit was tested and flushed before leaving our facility. In order to help provide years of trouble free usage, please review the following documentation and make sure to clean and flush the field piping before connecting it to the power unit.

Refer to schematic diagrams and the BOM (Bill of Materials) for component part specifications and recommended spare parts.

READ THIS MANUAL THOROUGHLY BEFORE OPERATING AND / OR WORKING ON THE EQUIPMENT



1. Read and follow any safety instructions in the CATERPILLAR ENGINE OPERATOR'S MANUAL.
2. Only well-trained and experienced personnel should attempt to operate or maintain this equipment.
3. **NEVER** adjust, lubricate or repair the unit when it is in operation or lifted above ground level.
4. **NEVER** remove, paint over and/or cover warning or safety labels. If labels become damaged or unreadable, replace immediately.
5. All personnel should wear approved safety clothing, including HARD HATS, SAFETY SHOES, SAFETY GLASSES and HEARING PROTECTION when near this equipment.
6. Do **NOT** stand any closer to this equipment than necessary when it is in operation. Parts may loosen and fall. Dirt and rocks may fall from flighting. **NEVER** stand under operating or elevated equipment.
7. When maintaining and/or repairing the equipment, **NEVER** substitute parts not supplied or approved in writing by APE.



Do **NOT** weld or flame cut on this equipment.

8. **NEVER** use or store flammable liquids on or near the engine.
9. Insure that all lifting equipment, including cranes, wire rope, slings, hooks, shackles, etc., are properly sized for the worst case loads anticipated during operations.
10. If there are any questions about the weights, specifications or performance of the unit, contact APE before handling and/or operating the equipment.
11. If the equipment is to be used for anything other than drilling plumb holes, contact APE before using the unit.
12. Check wire rope clips for tightness and wire ropes for wear daily.
13. Insure that ground vibrations will not damage or collapse adjacent structures or excavations.
14. Remove all tools, parts and electrical cords before starting the unit.

(These precautions must be followed at all times to ensure personal and equipment safety.)



When operating in an enclosed area, exhaust fumes should be piped outside.

Continued breathing of exhaust fumes may prove FATAL.



A properly maintained fire extinguisher, suitable for oil fires, MUST be kept in the immediate vicinity of equipment operations.

15. When servicing batteries, do **NOT** smoke or use an open flame in the vicinity. Batteries generate explosive gas during charging. There must be proper ventilation when charging batteries.
16. When filling the fuel tank, do **NOT** smoke or use an open flame in the vicinity.
17. If abnormal equipment operation is observed, discontinue use immediately and correct the problem.
18. Do **NOT** leave the equipment control pendant (radio control) unattended.
19. Store oily rags in approved containers and away from the engine exhaust system.
20. Make sure that the Auger rotation switch is in NEUTRAL before starting the Power Unit engine.
21. Do **NOT** adjust and/or set the hydraulic pressures higher or lower than those specified in this Manual.
22. **NEVER** operate this equipment with hydraulic hoses that are damaged or 'kinked'. Replace damaged hoses immediately.
23. Do **NOT** lift and/or support hydraulic hoses with wire rope slings.
24. **NEVER** attempt to connect Quick Disconnects (QDs) when the Power Unit is running.
25. Do **NOT** pull on and/or attempt to move equipment with the hydraulic hoses.
26. Do **NOT** attempt to locate hydraulic leaks with your hands. High-pressure leaks can penetrate skin and cause severe damage, blood poisoning and/or infection.
27. Do **NOT** attempt to repair leaks while the equipment is in operation.
28. Do **NOT** attempt to tighten and/or loosen fittings and/or hoses when the machine is in operation.
29. Power Unit must always be placed on level, stable ground.
30. Do **NOT** remove Power Unit heat shields. Do **NOT** attempt to use the Power Unit without heat shields. Severe fires may result.
31. When moving and/or transporting this equipment, insure that the vehicle or vessel is of sufficient capacity to handle the load. Make sure that the equipment is properly tied down.
32. When moving and/or transporting this equipment, be sure that the QD Dust Caps are tight and that the cap safety cables are in place. Be sure that all equipment parts are tight and/or properly secured before shipment. Unsecured parts may vibrate loose and fall during transport causing injury and/or property damage.
33. Rounded and/or damaged bolt heads and/or nuts should be replaced so that proper torque values may be obtained. Proper torque values are necessary to prevent parts on this equipment, leads and/or crane booms from loosening and/or falling. (Refer to the torque chart in this manual for the proper values.)
34. KEEP HANDS AWAY FROM ROTATING FLIGHTING, AUGER SHAFT AND/OR ROTARY JOINT.
35. KEEP HANDS, FEET AND TOOLS WELL CLEAR OF THE FLIGHTING GUIDES.
36. Do **NOT** allow clothing, hoses, ropes, etc., to become entangled in, or wrap around, rotating flighting, Auger shaft and/or rotary joint.
37. When operating in a closed area, pipe exhaust fumes outside. (Warning: Breathing exhaust fumes can cause serious injury or even death.)
38. Make sure the control pendant is in the "LOCAL" position before starting the unit.
39. **NEVER** stand under hammer at any time and keep you eyes on the hammer when it is in operation.
40. When loading or unloading the power unit using a forklift, the forks must be placed under the entire depth of the unit.

WARRANTY INFORMATION

American Piledriving Equipment, Inc. (APE) warrants new products sold by it to be free from defects in material or workmanship for a period of two (2) years after the date of delivery to the first user and subject to the following conditions:

- APE's obligation and liability under this WARRANTY is expressly limited to repairing or replacing, at APE's option, any parts which appear to APE upon inspection to have been defective in material or workmanship. Such parts shall be provided at no cost to the user, at the business establishment of APE or the authorized APE distributor of the product during regular working hours.
- This WARRANTY shall not apply to component parts or accessories of products not manufactured by APE, and which carry the warranty of the manufacturer thereof, or to normal maintenance (such as engine tune-up) or normal maintenance parts (such as filters).
- Replacement or repair parts installed in the product covered by this WARRANTY are warranted only for the remainder of the warranty as if such parts were original components of said product.
- APE makes no other warranty, expressed or implied, and makes no warranty of merchantability or fitness for any particular purpose.
- APE's obligations under this WARRANTY shall not include any transportation charges, costs of installation, duty, taxes or any other charges whatsoever, or any liability for direct, indirect, incidental or consequential damage or delay.
- If requested by APE, products or parts for which a warranty claim is made are to be returned, transportation prepaid, to APE.

OIL MUST MEET ISO CLEANLINESS CODE 17/15/11.
OIL THAT DOES NOT MEET CLEANLINESS CODE
WILL **VOID** THE WARRANTY

ANY IMPROPER USE, INCLUDING OPERATION AFTER DISCOVERY OF DEFECTIVE OR WORN PARTS, OPERATION BEYOND RATED CAPACITY, SUBSTITUTION OF ANY PARTS WHATSOEVER, USE OF PARTS NOT APPROVED BY APE OR ANY ALTERATION OR REPAIR BY OTHERS IN SUCH A MANNER AS, IN APE'S JUDGMENT, AFFECTS THE PRODUCT MATERIALLY AND ADVERSELY, SHALL **VOID** THIS WARRANTY.

ANY TYPE OF WELDING ON APE'S EQUIPMENT WILL **VOID** THE WARRANTY UNLESS AUTHORIZED IN WRITING BY APE

NO EMPLOYEE AUTHORIZED TO CHANGE THIS WARRANTY IN ANY WAY OR GRANT ANY OTHER WARRANTY UNLESS SUCH CHANGE IS MADE IN WRITING AND SIGNED BY AN OFFICER OF APE, INC.

FOREWORD

This manual covers the **APE 50BB Auger** installation, maintenance and use.

This manual provides the necessary information to operate and maintain APE equipment. The listed procedures are to be performed by qualified personnel who have an understanding of the equipment and who follow all safety precautions.

All information given in this manual is current and valid according to the information available at the time of publication. American Piledriving Equipment, Inc. reserves the rights to implement changes without prior notice.

Using this manual:

- Refer to the Table of Contents for the page location of applicable sections.
- All weights and measurements are in English and Metric units.
- Any revisions to this manual will appear on the Revision Record page at the back of this manual. The revisions themselves will be attached to the back of the manual and entitled ADDENDA with references back to the page in question in the original manual.
- Please visit www.apevibro.com for product data sheets and manual.

DISCLAIMER:

This unit was tested and flushed before leaving our facility. In order to help provide years of trouble-free usage, please review the following documentation and make sure to clean and flush the field piping before connecting it to the power unit.

Refer to schematic diagrams and the BOM (Bill of Materials) for component part specifications and recommended spare parts.

When calling APE, always have the equipment serial number on hand in order to obtain quicker service.

TABLE OF CONTENTS

GENERAL INFORMATION	1
Safety / Warning Labels.....	1
Daily Checklist	2
Lifting the Auger Drill	3
Connecting / Filling the Hydraulic Lines	4
Commissioning Procedure	5
Flushing the Hydraulic System	5
Air Bleed Procedure	5
Break-In Period.....	6
Fluid Cleanliness.....	6
Operating Pressures	7
Operating Temperatures	7
Valves	9
TROUBLESHOOTING	10
Hydraulic Schematic.....	10
MAINTENANCE	11
Maintenance Chart	11
Storage	12
Routine Maintenance.....	13
REPLACEMENT PARTS.....	14
Complete Auger	14
Lifting Bale.....	16
Grout Swivel.....	17
18" Guide	19
Drive Manifold	20
REFERENCE / NOTES.....	21

SPECIFICATIONS

50 BB

DIMENSIONS

Overall Length	37 in	(94 cm)
Overall Width	52 in	(132 cm)
Overall Height	88 in	(224 cm)

Low Speed High Torque

Torque	9,688 ft-lbs per 1000 PSI	1,339 kgm per 69 bar
Max Pressure	5,800 psi	400 bar
Rotation Speed	36 rpm	
Max Flow	120 gpm @ 3.3 gal / rev	454 lpm @ 12.6 lit / rev
Max Horse Power	406 hp	303 kW

High Speed Low Torque

Torque	4,844 ft-lbs per 1000 PSI	670 kgm per 69 bar
Max Pressure	5,800 PSI	399.6 bar
Rotation Speed	72 rpm	
Max Flow	120 gpm @ 1.7 gal / rev	454 lpm @ 12.6 lit / rev
Max Horse Power	320 hp	239 kW

Misc Specifications

Crowd Force	150,000 lbs	68,039 kg
Suspended Weight	4,530 lbs	2,055 kg
ID of Output Shaft	3 in	76.2 mm
ID of Rotary Joint	3 in	76.2 mm
Adapters	3 inch / 4 inch	

SPECIFICATIONS

75 BB

DIMENSIONS

Overall Length	37 in	(94 cm)
Overall Width	52 in	(132 cm)
Overall Height	88 in	(224 cm)

Low Speed High Torque

Torque	12,150 ft-lbs per 1000 PSI	1,680 kgm per 69 bar
Max Pressure	5,800 psi	400 bar
Rotation Speed	30 rpm	
Max Flow	120 gpm @ 3.3 gal / rev	454 lpm @ 15.8 lit / rev
Max Horse Power	508 hp	379 kW

High Speed Low Torque

Torque	6,075 ft-lbs per 1000 PSI	840 kgm per 69 bar
Max Pressure	5,800 PSI	400 bar
Rotation Speed	60 rpm	
Max Flow	120 gpm @ 1.7 gal / rev	454 lpm @ 7.9 lit / rev
Max Horse Power	406 hp	303 kW

Misc Specifications

Crowd Force	150,000 lbs	68,039 kg
Suspended Weight	4,630 lbs	2,100 kg
ID of Output Shaft	3 in	76.2 mm
ID of Rotary Joint	3 in	76.2 mm
Adapters	3 inch / 4 inch	

SPECIFICATIONS

80 BB

DIMENSIONS

Overall Length	37 in	(94 cm)
Overall Width	52 in	(132 cm)
Overall Height	88 in	(224 cm)

Low Speed High Torque

Torque	14,572 ft-lbs per 1000 PSI	2,015 kgm per 69 bar
Max Pressure	5,075 psi	350 bar
Rotation Speed	30 rpm	
Max Flow	125 gpm @ 5 gal / rev	473 lpm @ 18.9 lit / rev
Max Horse Power	401 hp	300 kW

High Speed Low Torque

Torque	7,266 ft-lbs per 1000 PSI	1,004.56 kgm per 69 bar
Max Pressure	5,075 PSI	350 bar
Rotation Speed	61 rpm	
Max Flow	125 gpm @ 2.5 gal / rev	473 lpm @ 9.5 lit / rev
Max Horse Power	328 hp	245 kW

Misc Specifications

Crowd Force	150,000 lbs	68,039 kg
Suspended Weight	4,630 lbs	2,100 kg
ID of Output Shaft	3 in	76.2 mm
ID of Rotary Joint	3 in	76.2 mm
Adapters	3 inch / 4 inch	

GENERAL INFORMATION

Safety / Warning Labels



This information is important when contacting APE for replacement parts or other information.

- * Model
- * Serial No.

Daily Checklist



Check the entire unit prior to and during set-up each day or at the beginning of each shift

Prior to starting the unit or at the beginning of each shift, check the following:

- Visually inspect all bolts, nuts and screws.
- Grease Sheave pin.
- Grease Grout Swivel
- Visually inspect all hydraulic fittings for leaks. If a leak is found or suspected, shutdown the power unit. If a fitting appears to be damaged, replace with a new fitting.



It is absolutely imperative that no dirt or other impurities be permitted to contaminate the hydraulic fluid. Any contamination will drastically shorten the life of the high-pressure hydraulic system.



Vibration loosens bolts. Check them thoroughly.

Lifting the Auger Drill

The following instructions apply to all procedures associated with the motor. Read these instructions carefully and follow them closely.

- Use necessary Personal Protective Equipment (PPE) when working with the motor.
- Support the motor properly. Make sure that the motor cannot fall over or accidentally turn around.
- Use only appropriate equipment and attachments for lifting and transferring the motor.
- Always use the lifting equipment properly and check the load bearing capacity.
- Prevent unintended use of the motor during installation and maintenance procedures by preventing the pressurization of the hydraulic lines.
- The operating temperature of the motor may be over 60° C (140° F) which is hot enough to cause severe burns.



Beware of hot hydraulic fluid when disconnecting the hydraulic connections



Connecting / Filling the Hydraulic Lines

Connecting the hoses is one of the most critical aspects of commissioning an APE driver. Take extreme care to keep these connections absolutely clean. This procedure is one of the most common ways for foreign particles to be introduced into a hydraulic system.

Attention!

New hydraulic fluid is NOT clean oil!

***Oil must meet ISO cleanliness code
17/15/11***

- Connect the hose bundle. Make sure all connections are properly tightened
- Fill the motor case with clean hydraulic fluid



CAUTION

While filling the hydraulic lines, the drill motor shaft will rotate.

Please do the following:

- Set the engine at idle
- Run at idle for about 10 minutes to fill the lines
- Energize 'Drive Fwd' - The motor shaft will rotate slowly and push any remaining air in the lines back to the reservoir

Attention!

Pressurizing the system while there is air entrained in the fluid may cause damage to the components.

Let the system run at idle for an additional 10 minutes to allow the air to rise into the airspace of the hydraulic reservoir.

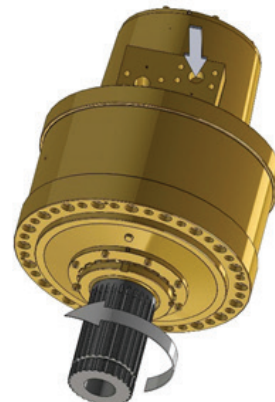

Commissioning Procedure

Attention!

Do not start the motor if the air bleeding procedure has not been carried out.

Stressing an unused motor with full power may cause premature wear or failure.

Ensure that the following steps are met before starting a new or rebuilt auger drill:

- The hydraulic circuit of the motor is flushed
- The motor is installed appropriately
- An air bleeding procedure is carried out
- The reservoir of the hydraulic system is full

During the initial stages of starting a new or rebuilt helical driver, please consider the following:

- Do **NOT** run the motor immediately with full power
- Increase the load and speed of rotation gradually
- Observe the motor and the hydraulic system for external leaks or abnormal noises during the commissioning procedure
- Start the motor break-in period

Flushing the Hydraulic System

Prior to connecting the motor as part of the hydraulic system, the hydraulic circuit of the motor must always be flushed. This is done by circulating the hydraulic fluid through a filter installed in place of the motor.

Flushing the hydraulic system should be performed after every service and/or repair.

The helical pile driver is usually shipped with the drive motor hoses full of hydraulic oil and the unit may be used immediately.

If the drive hoses have been removed from the driver motor they will need to be filled before full speed operation.

Air Bleed Procedure

The air bleeding procedure is carried out to completely fill the housing of the motor with hydraulic fluid. Air is removed from the housing with air bleeding screws as follows:

- Connect port 'C2' to a drain line and feed hydraulic fluid into the motor via port 'C1' throughout the air bleeding procedure.
 - Locate the topmost air bleed screw of the housing
 - Unscrew the air bleeding screw by half a turn and let the air escape from the housing
 - Close the screw when only hydraulic fluid is pouring through it
 - Tighten the screw to a torque of 28 lbf/ft (39 +/- 3 Nm)

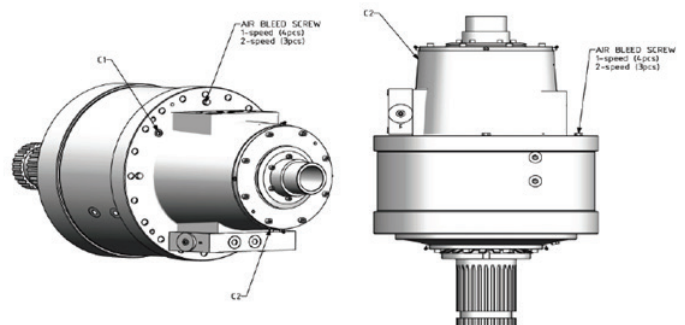

Break-In Period

New motors require a break in procedure.

The motor achieves its final properties during the first hours of use. All new and reconditioned motors should go through an initial break-in period.

Items to consider during this period:

- Break-in should last for, at least, **the first 8 hours of use.**
- The power output should remain under **50% of the maximum power capacity** of the motor.
- To limit the power output, constrain the working pressure, speed of rotation or both.
- The working pressure should be curbed so that pressure peaks which last over 2 seconds (2s) remain under 75% of the allowed pressure.



During this break-in period, the moving parts of the motor wear against each other. This means the wear of the parts sets to a stable state for the entire service life of the motor.

Fluid Cleanliness



It is imperative that the hydraulic fluid is kept clean to a minimum ISO Code 17/15/11

New hydraulic fluid is NOT clean oil

(See attached document 'Understanding ISO Codes)

(See Warranty document regarding fluid cleanliness)

Bulk oil does not typically meet the cleanliness standards required by APE equipment.

Operating Pressures

Charge Pressure

The charge pressure is used to ensure that the pistons of the motor stay constantly engaged to the cam ring. Depending upon the operation function, the charge pressure is required either in the feed or return line (working line ports A or B).

The recommended charge pressure is **200PSI or 13.8 bar higher than the case pressure**. The actual required charge pressure depends upon the viscosity and flow rate of the hydraulic fluid.

The required charge pressure in the return line (back pressure) is only 73psi (5 bar) higher than the case pressure if the motor is **NOT** switched to partial displacement or short circuit connection.

Attention!

Charge pressure that is too low may cause the pistons to disengage from the cam ring causing A clattering noise when the pistons re-engage. This condition will cause damage to the driver motor.

Constant use with a charge pressure that is too low may cause premature wear or failure of the motor.

Case Drain

The case drain line is the return line for the driver housing cavity. Case pressure is induced by the pressure drop in the case drain line. The case drain line is connected to port 'C2' on the motor and 'DR2' port on the drive manifold.

It is imperative that the case drain has an unobstructed route back to the hydraulic reservoir. If a case drain filter is required, consult the factory for proper sizing.

Operating Temperatures

The Operating Temperature references the internal temperature of the motor.

Take into consideration the following requirements:

- 70°C (158°F) – Avoid going over this Operating Temperature for improved service life
- 85°C (185°F) – Highest permissible intermittent Operating Temperature
- -35°C (-31°F) – Lowest permissible Operating Temperature
- 60°C (140°F) – Temperature difference between the motor and the hydraulic fluid

The Operating Temperature may be measured from the hydraulic fluid returning from the motor. Take into account the temperature of the hydraulic fluid returning from the case drain line.



The APE Auger Drill has a 2-speed direct drive Radial Piston Motor.

Full Displacement Mode:

- All of the pistons are engaged to deliver maximum torque
- Full displacement mode is limited to ½ maximum output speed

Half Displacement Mode:

- ½ of the pistons are engaged to deliver double speed
- Half displacement mode is limited to ½ maximum output torque

Changing displacement while drilling is permissible. To ‘shift on the fly’ it is necessary to hold the displacement shift spool in position with a minimum of 650PSI.

A 2-position, 4-way, Pilot Valve is required to select displacement.

Full Displacement	Activate Port: Y2	Drain Port: Y1
-------------------	-------------------	----------------

Half Displacement	Activate Port: Y1	Drain Port: Y2
-------------------	-------------------	----------------



NOTE: In some applications the maximum pressure setting for half displacement mode must be lowered due to through-put horsepower limitations internal to the motor. Refer to the data sheet of the specific motor installed.

When the motor is transitioning from full displacement to half displacement, the load induced pressure will double.

When the motor is transitioning from half displacement to full displacement, the flow requirement will double.

AVOID SHIFTING FROM HALF TO FULL WHEN THE MOTOR IS TURNING IN EXCESS OF ½ OF THE MAXIMUM SPEED.

Valves

The drill has an integral valve package designed to protect the motor from damage. (Refer to the hydraulic schematic Figure 7 / Page 19 for details)

- Pressure filters clean the hydraulic fluid going to the drill motor and manifold in the forward and reverse directions.
- Vented Relief Valves - VR1 and VR2: Limit the maximum pressure that the drill motor is exposed to. When the load induced pressure exceeds the setting of the vented relief, the valve will open creating a short circuit around the drill motor.
- The vented Relief Valve may be set to a lower setting by energizing the Directional Valve (DV1) which connects the pilot section of VR1 and VR2 to the secondary Pilot Relief Valve (RV1).
- Some motors are limited in their capacity to carry 'through-out horsepower' when they are in the high speed/half displacement mode.
- Check Valves - CV2 and CV3: These isolate the pilot sections of VR1 and VR2 from each other.
- Counterbalance Valves - CB1 and CB2: These are in-line with the drill motor and set at 400PSI. Their primary function is to maintain 'charge pressure' to the drill motor.
- Hot Oil Shuttle Valve - HOS1: This will shift when the drill is activated to direct oil flow from the low-pressure side to flush the case of the drill motor.
- Flow Control Valve - FC2: This regulates the amount of case flushing flow.
- Check Valves - CV4 and CV5: These connect the high-pressure side when the drill is activated. This will supply the Accumulator with pressurized hydraulic fluid to be stored for additional charge pressure.
- Flow Control Valve - FC1: This limits the rate of flow being diverted to the Accumulator.
- Pressure Reducing Valve – PRV: This is a normally open valve that will close when the pressure being stored in the Accumulator exceeds the PRV setting. If the pressure in either motor line drops below this setting, the PRV will open thus allowing the fluid stored in the Accumulator to keep the motor ports pressurized.
- Check Valves - CV6 and CV7: These create direct flow from the Accumulator circuit to the low-pressure side of the drill motor.
- Pop Off Valve - PO1: This is intended to protect the drill motor case from over-pressurization.

Hydraulic Schematic

NOTES:

1. These pressure settings are specific to the Black Bruin (BB) Drill
2. Maximum flow rate is 120 GPM

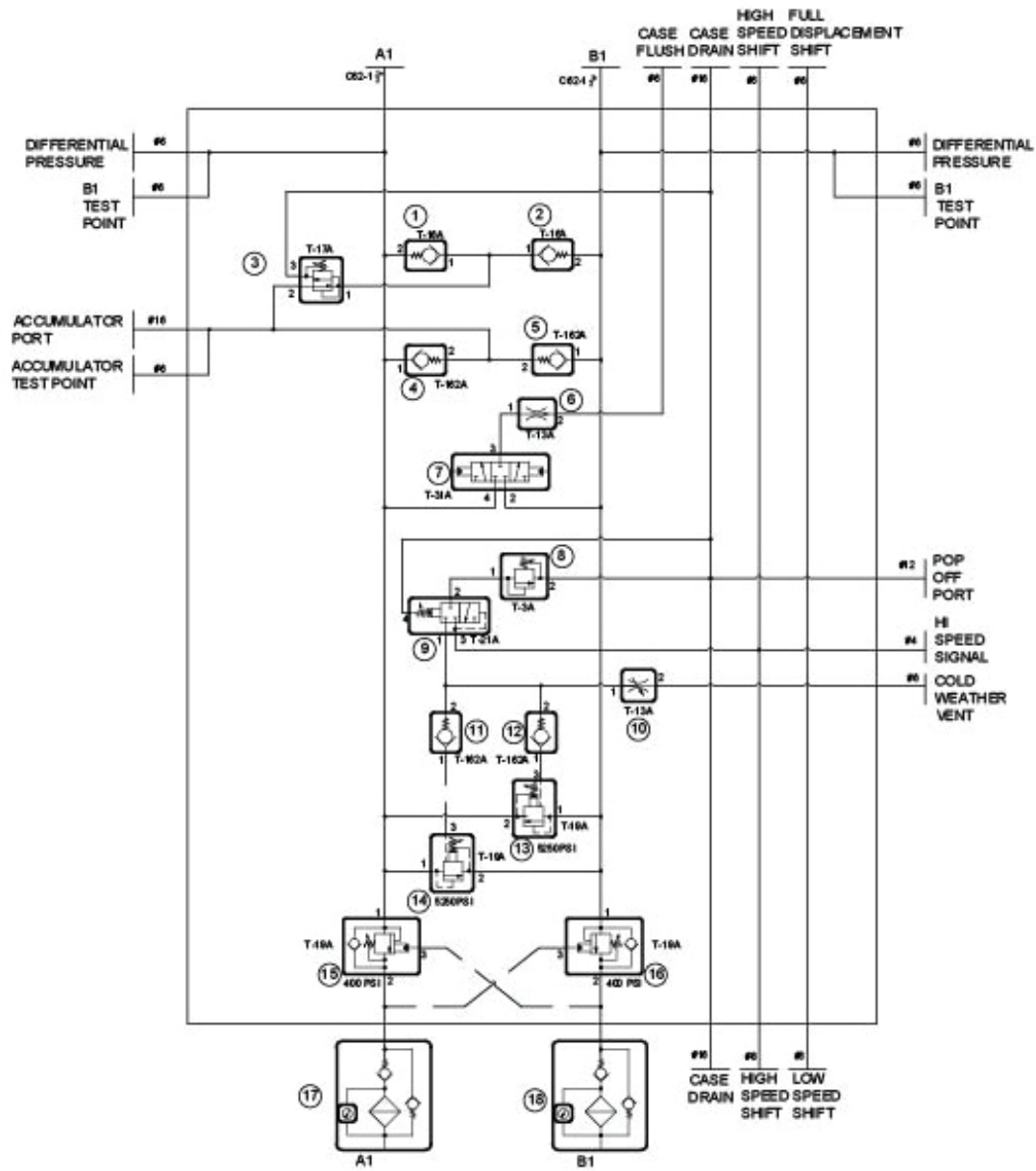

MAINTENANCE

Maintenance Chart

DAILY	WEEKLY	250 HOURS OR 6 MONTHS	1500 HOURS OR 1 YEAR	6000 HOURS OR 2 YEARS	6000 HOURS OR 3 YEARS
<ul style="list-style-type: none"> • Check operator's report • Check oil and bring to correct level • Check coolant and bring to correct level • Visually inspect fan • Visually inspect engine for damage, leaks, loose or frayed belts and correct or record or future action • Drain fuel-water separator 	<ul style="list-style-type: none"> • Check air intake system for wear points or damage to piping, loose clamps, and leaks. • Check air cleaner restriction • Check and clean air cleaner element • Drain moisture from tanks 	<ul style="list-style-type: none"> • Change lubricating oil • Change lubricating oil filters • Change fuel filter • Clean crankcase breather • Check engine coolant concentration level • Replace final fuel filter/clean primary fuel filter. Drain water from fuel tank • Inspect/replace alternator fan and accessory drive belts • Inspect/replace hoses and clamps • Lubricate fan drive bearings • Clean/check battery electrolyte level 	<ul style="list-style-type: none"> • Adjust valves and injectors • Steam clean engine • Check torque on turbocharger mounting nuts • Check torque on engine mounting bolts • Replace hoses as required • Check/adjust engine valve lash • Check/adjust low idle speed • Test/exchange fuel injection nozzles • Inspect/rebuild alternator 	<ul style="list-style-type: none"> • Clean cooling system and change coolant and antifreeze • Inspect Temperature regulator • Inspect/rebuild turbocharger • Inspect/rebuild starter 	<ul style="list-style-type: none"> • Clean and calibrate the following: <ul style="list-style-type: none"> • -Injectors • -Fuel pump • -Fan Clutch • -Water pump • -Fan Hub • -Fan idler pulley assembly • -Vibration dampener

Follow the manufacturer's recommended maintenance procedures for the starter, alternator, batteries, electrical components, and fan clutch.

At each scheduled maintenance interval preform all previous checks which are due for scheduled maintenance.



Preventative maintenance includes normal servicing that will keep the power unit in peak operative condition and prevent unnecessary trouble from developing. This servicing consists of periodic lubrication and inspection of moving parts and accessories of the unit.

Lubrication is an essential part of preventative maintenance controlling, to a great extent, the useful life of the unit. Different lubricants are needed and some components in the unit require more frequent lubrication than others. Therefore, it is important that the instructions regarding types of lubricants and frequency of their application be closely followed.

To prevent minor irregularities from developing into serious conditions that might involve shutdown and major repair, several other services or inspections are recommended for the same intervals as the periodic lubrications. The purpose of these services or inspections is to assure the uninterrupted operation of the unit.

- Thoroughly clean all lubrication fittings, caps, filler and level plugs along with their surrounding surfaces before servicing.
- Prevent dirt from entering with lubricants and coolants.

The intervals given in the schedule are based upon normal operation.

Perform these services, inspections, etc., More often as needed for operation under abnormal or severe conditions.

Storage

During short-term storage of a power unit, the following should be taken into consideration:

- Cover any pressure openings and open threaded holes with suitable caps.
- Protect the unpainted surfaces from dirt and moisture.
- Do NOT store the power unit in an area with substances that have an aggressive corrosive nature, i.e. solvents, acids, alkalies or salts.

For long-term storage (over 9 months), the following additional actions are recommended:

- Repair any damage to surface paint before item is stored.
- Protect the unpainted surfaces with suitable anti-corrosion treatment such as CRC SP-350, CorrosionX corrosion inhibitor, or WD-40 Long Term Corrosion Inhibitor.
- Fill the power unit completely with hydraulic fluid.



If these instructions are followed to the letter, the motor may be stored for approximately 2-years. However, as storage conditions do have a significant effect, all suggested time frames should only be considered as guide values.

Routine Maintenance

APE recommends using grease having the following requirements:

- Operating temperature range: -40°F - 320°F
- Mineral oil based lithium soap grease
- Consistency class: NLGI #1
- Meet DIN KP2.5K-30 or ISO-L-XCCIB2.5 standard specifications

Attention!

**DO NOT USE A PNEUMATIC GREASE GUN
SEAL DAMAGE MAY OCCUR**

Every 40 hours, do the following:

- Grease the top seal by pumping grease into either grease fitting until clean grease comes out of the Relief Valves. (Figure 11)
- When the Top Drive Auger is washed down, it is very important and helpful to grease the top seal to see the water come out along with clean grease out of the Relief Valves.
- Visually check all hoses for signs of damage or cuts that might cause hose failure during operation. Be sure that all connections are tight.
- Grease the rotary joint packing box (the upper fitting) with 3 to 5 shots of any good multi-purpose grease at the beginning of the shift and then every 2-4 hours always while rotating under no pressure (Figure 12).
- Grease the rotary joint bearing housing (the lower fitting) with any good multi-purpose grease after 1-hour of rotating until grease exits the bearing housing.
- **Check the nitrogen pre-charge every filter element change. Nitrogen pressure should be 150 PSI.**

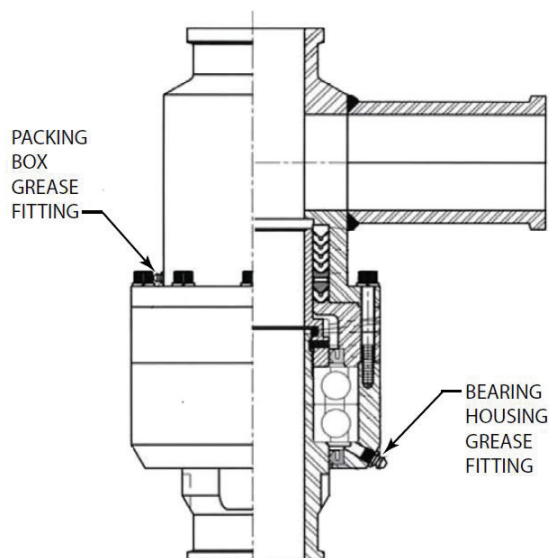
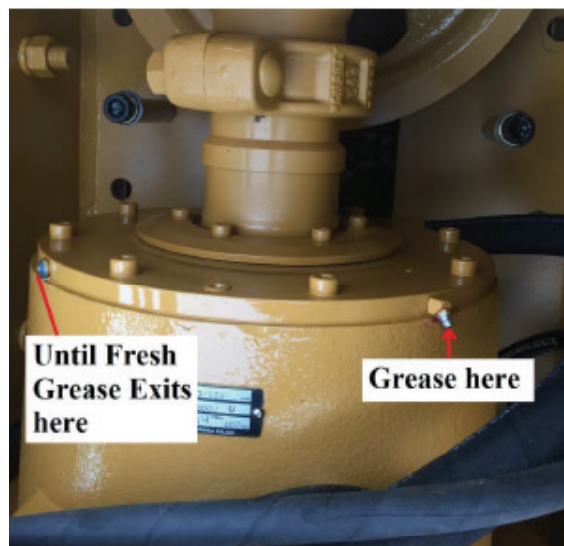

REPLACEMENT PARTS

Complete Auger

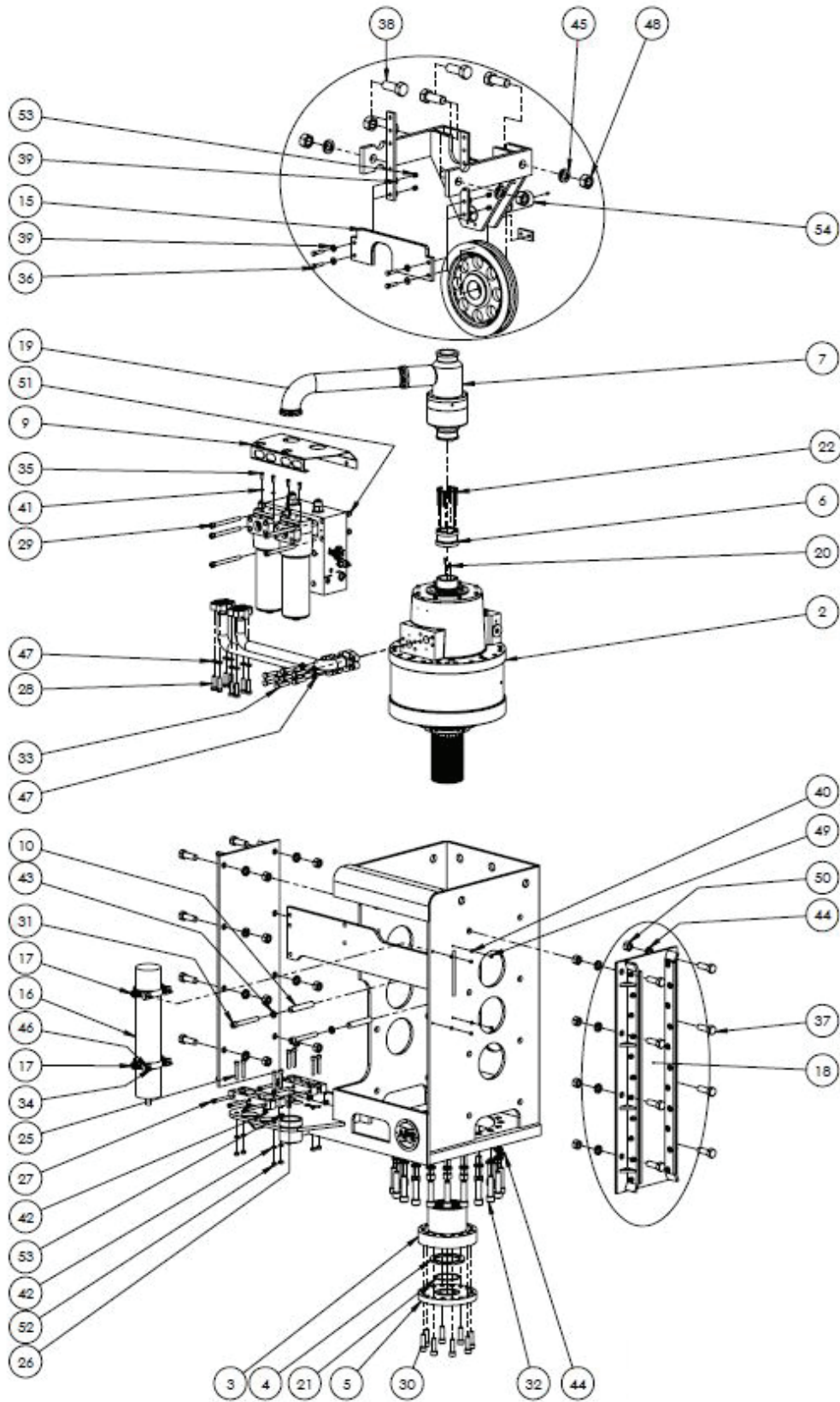

REPLACEMENT PARTS

CALLOUT	PART NUMBER	APE PART NUMBER	DESCRIPTION	QTY
1		1004161	DH50 Skid	1
2	SD158340002		Black Bruin Motor	1
3		600530BB	Drive Hub	1
4		630511	Split Ring	1
5		630514	Seal Plate	1
6		1000595	Grout Adapter Black Bruin	1
7		630001	3 IN Rotary Joint	1
8	016018	1004515	Drill Manifold ASM	1
9		1004275	Manifold Guard	1
10		1006092	Cable Guide Spacer	2
11		1004267	Pipe Assembly A	1
12		1004268	Pipe Assembly B	1
13		1004258	Hose Clamp -6 -6 -16	2
14		1004259	Hose Clamp -24 -24	2
15		1006076	Anti-Rotational Stop	1
16		1000397	Accumulator	1
17		1001044	Accumulator Mount	2
18		1005201	Guide Rail Assembly 26 x 8	1
19		1004272	Grout Tube	1
20			8mm x 25mm Hardened pin	2
21	2-347	100712	Seal Plate O- Ring	1
22	SHCS M8-1.25 x 70		Grout Adapter To Motor	10
23	6801-06-06		-6 SAE to JIC 90°	7
24	6801-16-16		-16 SAE to JIC 90°-	2
25	SHCS 1/2-13 X 3		Hose Clamp To Skid	8
26	SHCS 1/2-13 X 3.75		-6 -6 -16 Hose Clamp	3
27	SHCS 1/2-13 X 4		-24 -24 Hose Clamp	3

REPLACEMENT PARTS

CALLOUT	PART NUMBER	APE PART NUMBER	DESCRIPTION	QTY
28	HBOLT 5/8-11 X 2.25		Hard Pipe to Manifold	8
29	SHCS 5/8-11 X 7		Manifold to Skid	5
30	SHCS 3/4-10 X 2.5		Seal Plate to Hub	8
31	SHCS 3/4-10 X 6		Cable Guide	2
32	SHXS 1-8 X 4		Motor to Skid	20
33	HBOLT M16-2.0 X 70		Hardpipe to Motor	8
34	HBOLT 5/16-18 X 1.25		Accumulator to Skid	4
35	HBOLT 3/8-16 X 1		Manifold Guard to Filter	4
36	HBOLT 1-8 X 3		Anti Rotational Stop	4
37	HBOLT 1-8 X 3		Guide Rail to Skid	16
38	HBOLT 1.5-6 X 4		Lifting Bale to skid	4
39	Regular FL 1/2		Anti Rotational Stop	8
40	Heavy LW 5/16		Accumulator to Skid	4
41	Regular LW 3/8		Manifold Guard to Filter	4
42	Heavy LW 1/2		Hose Clamps	14
43	Heavy LW 3/4		Cable Guide	2
44	Heavy LW 1		Motor to Skid / Guide Rails	36
45	Heavy LW 1.5		Lifting Bale to Skid	4
46	Regular FW 5/16		Accumulator to Skid	4
47	Heavy LW 5/8		Hard Pipe	16
48	HNUT 1.5-6		Lifting Bale to skid	4
49	HNUT 5/16-18		Accumulator to Skid	4
50	HNUT 1/2-13		Motor to Skid / Guide Rails	16
51	Nylock Nut 5/8-11		Manifold to Skid	5
52	HNUT 1/2-13		Hose Clamp to Skid	8
53	Nylock Nut 1/2-13		Anti-Rotational Stop / Hose Clamp	10
54	1004271		Lifting Bale Assembly	1

Grout Swivel

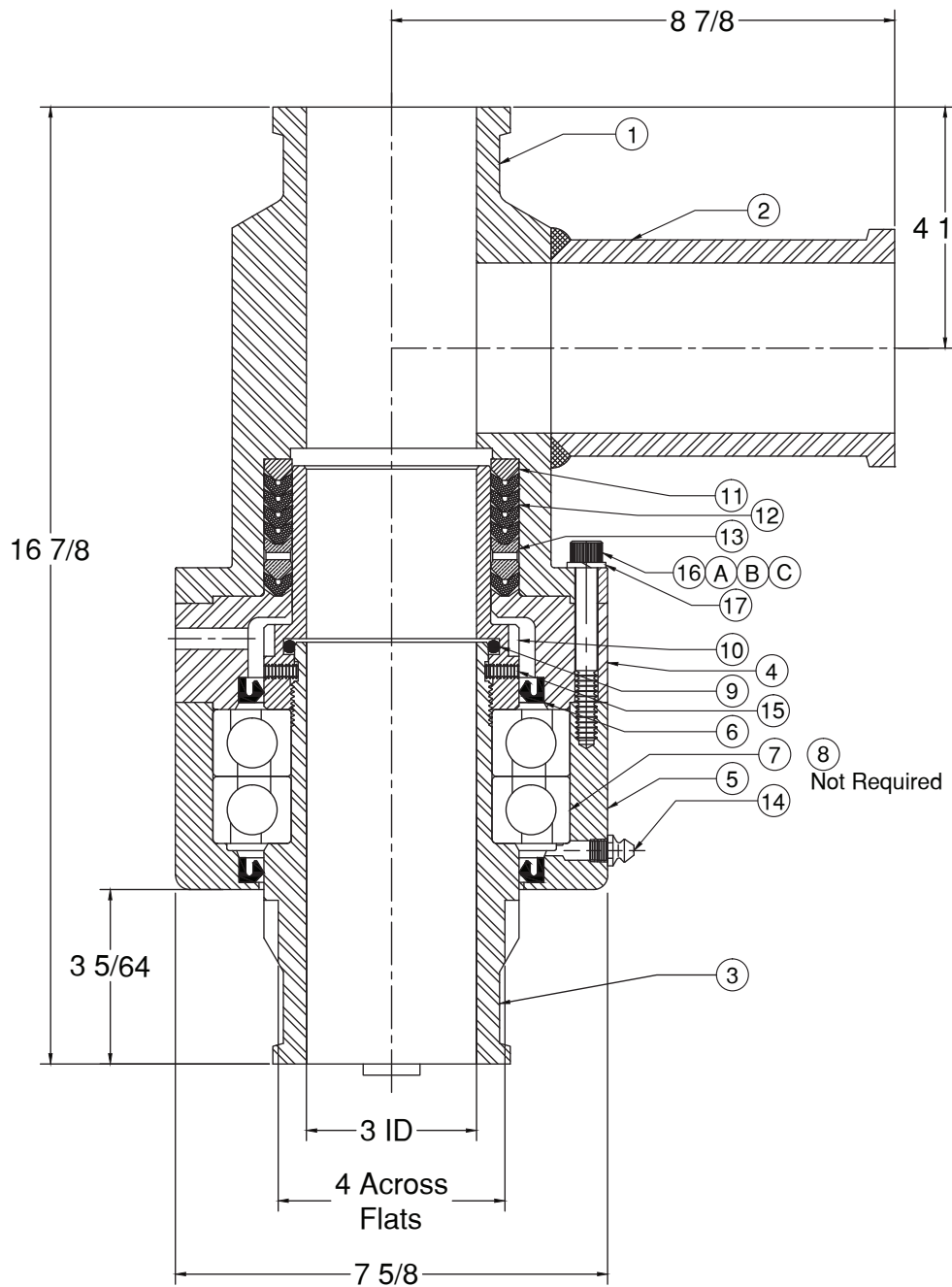

REPLACEMENT PARTS

CALLOUT	PART #	APE PART NUMBER	DESCRIPTION	QTY
1	3WRAM-01C		Gooseneck w/ Side Connection	1
2	3WRAM-01A		Side Connection	1
3	3WRAM-08A	630808A	Spindle 3" VIC	1
4	3WRAM-04		Adapter Plate	1
5	3WRAM-14		Bearing Housing	1
6	3WRAM07	630812	Grease Seal (Housing)	2
7	3BLW-12	630805	Bearing	2
8			Bearing Shim (not required)	1
9	OR-340	630810A	O-Ring (f washpipe)	1
10	3WRAM-25	630809	Washpipe w/ Set Screws	1
11	5JW-06S	630802	Packing Adapter (Steel)	1
12	3WRAM-20	630807	Packing (4 Rings)	SET
13	5JW-21	630808	Lantern Ring	1
14	S-GFITTINGS-.12		Grease Fitting	2
15	S-SHSS-0.25X0.62		Set Screw (Washpipe	2
16A	S-HHCS8-0.38-3.00		Bolt-Bearing Housing	10
16B	S-STUD8-0.38-4.00		Stud	2
16C	S-NUT8-0.38		Nuts	2
17	S-LW-0.38		Lock Washer	12

REPLACEMENT PARTS

Lifting Bale

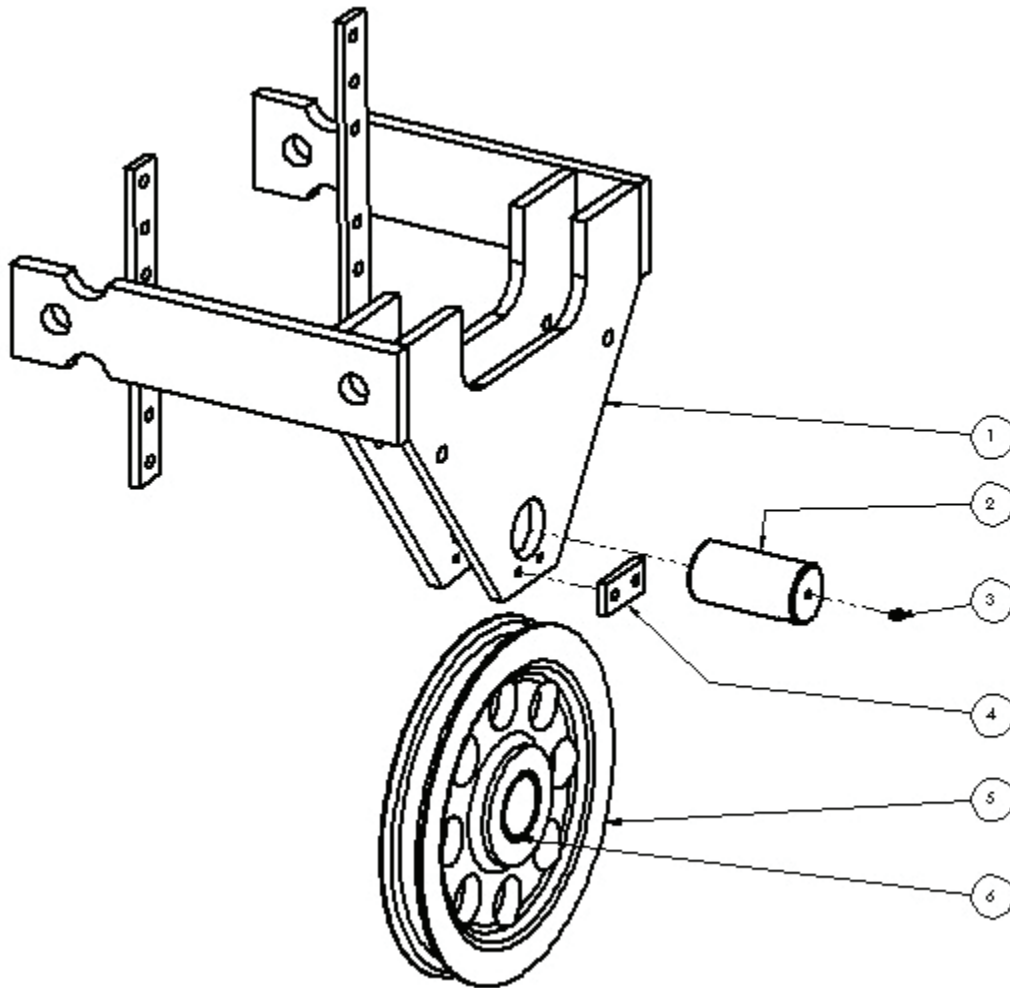

CALLOUT	APE PART NUMBER	DESCRIPTION	QTY
1	1004274	Lifting Bale Housing	2
2	1005021	Sheave Pin	1
3	221001	Grease Fitting-1/8 NPT Zert	1
4	1005022	Sheave Pin Keeper	1
5	950901	Sheave-Finished 18"	1
6	950903	Sheave Pin Bushing	1

GUIDE RAIL ASSEMBLY 1006084

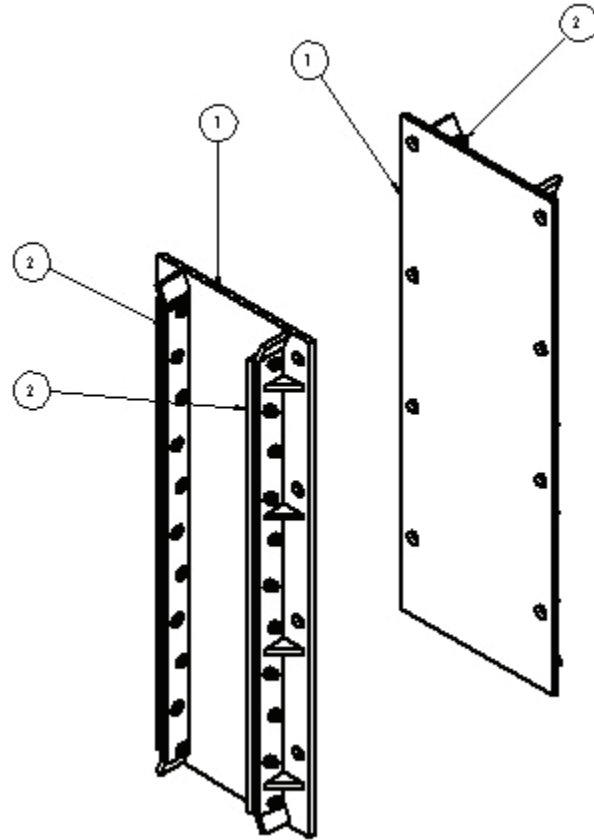

CALLOUT	APE PART NUMBER	DESCRIPTION	QTY
1	1005014	Guide Rail	2
2	1005023	Guide Rail Plastic	4
3	CS SHCS 1/2-13 X 1.75	Plastic to Guide Bolt	44
4	Nylock Nut 1/2-13	Plastic to Guide Nut	44

REPLACEMENT PARTS

Drive Manifold

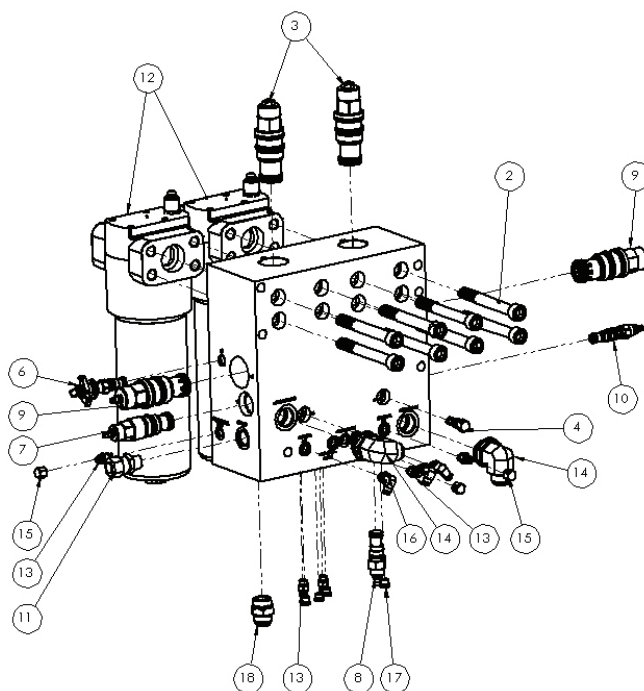

CALLOUT	PART NUMBER	APE PART NUMBER	DESCRIPTION	QTY
1		1004515	Manifold	1
2	SHCS 3/4-10 X 6.5		Filter Mount Bolts	8
3	CBIA-LBN	631063	3:1 Pilot Ratio Counterbalance Valve	2
4	CXBA-XCN	1000837	30 PSI Check Valve	2
5	FXCA-XAN		Fixed Orifice Flow Control Valve	1
6	NFCC-YCN		Fully Adjustable Needle Valve	1
7	PRHB-LAN		1000PSI Pressure Reducing Valve	1
8	RBAA-LAN		Direct Acting Relief Valve	1
9	RVIS-LCN		Poppet Relief Valve	2
10	DRBN-LDN		Directional Flow Valve Normally Closed	1
11		321009	Pop Off Relief	1
12	HS6013XXF32D13		Filter	2
13	6400-06-06		-6 SAE Straight	5
14	6801-16-16		-16 SAE to JIC 90°	2
15	304-C-06		-6 JIC Cap	3
16	6801-06-06		-6 SAE to JIC 90°	3
17	6408-HHP-06		-6 SAE Plug	4
18	6400-16-16		-16 SAE to JIC Straight	1

UNDERSTANDING ISO CODES

The ISO cleanliness code is used to quantify particulate contamination levels per milliliter of fluid at 3 sizes 4µ[c], 6µ[c], and 14µ[c]. The ISO code is expressed in 3 numbers (ie 19/17/14). Each number represents a contaminant level code for the correlating particle size. The code includes all particles of the specified size and larger. It is important to note that each time a code increases the quantity range of particles is doubling.

ISO 4406 Chart		
Range Code	Particles per milliliter	
	More than	Up to/including
24	80000	160000
23	40000	80000
22	20000	40000
21	10000	20000
20	5000	10000
19	2500	5000
18	1300	2500
17	640	1300
16	320	640
15	160	320
14	80	160
13	40	80
12	20	40
11	10	20
10	5	10
9	2.5	5
8	1.3	2.5
7	0.64	1.3
6	0.32	0.64

Sample 1 (see photo 1)

Particle Size	Particles per ml*	ISO 4406 Code range	ISO Code
4µ[c]	151773	80000-160000	24
6µ[c]	38363	20000-40000	22
10µ[c]	8229		
14µ[c]	3339	2500-5000	19
21µ[c]	1048		
38µ[c]	112		

Sample 2 (see photo 2)

Particle Size	Particles per ml*	ISO 4406 Code range	ISO Code
4µ[c]	492	320 - 640	16
6µ[c]	149	80 - 160	14
10µ[c]	41		
14µ[c]	15	10 - 20	11
21µ[c]	5		
38µ[c]	1		

Photo 1

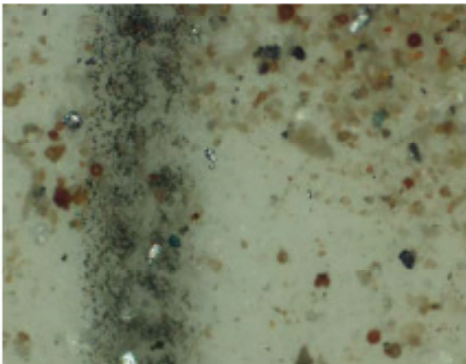
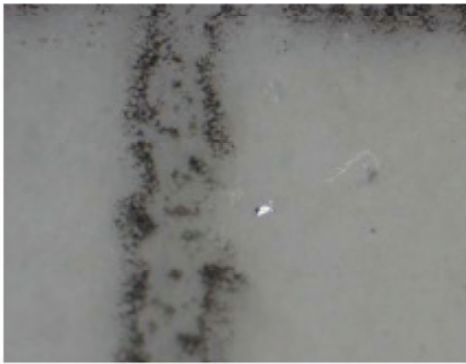

Photo 2



TARGET ISO CLEANLINESS CODES

When setting target ISO fluid cleanliness codes for hydraulic and lubrication systems it is important keep in mind the objectives to be achieved. Maximizing equipment reliability and safety, minimizing repair and replacement costs, extending useful fluid life, satisfying warranty requirements, and minimizing production down-time are attainable goals. Once a target ISO cleanliness code is set following a progression of steps to achieve that target, monitor it, and maintain it, justifiable rewards will be yours.

Set the Target.

The first step in identifying a target ISO code for a system is to identify the most sensitive or an individual system, or the most sensitive component supplied by a central reservoir. If a central reservoir supplies several systems the overall cleanliness must be maintained, or the most sensitive component must be protected by filtration that cleans the fluid to the target before reaching that component.

Other Considerations

Table 1 recommends conservative target ISO cleanliness codes based on a several component manufacturers guidelines and extensive field studies for standard industrial operating conditions in systems using petroleum based fluids. If a non-petroleum based fluid is used (i.e. water glycol) the target ISO code should be set one value lower for each size (4 µl(c)/8µl(c)/14µl(c)). If a combination of the following conditions exists in the system the target ISO code should also be set one value lower:

- Component is critical to safety or overall system reliability.
- Frequent cold start.
- Excessive shock or vibration.
- Other severe operation conditions.

Recommended* Target ISO Cleanliness Codes and media selection for systems using petroleum based fluids per ISO4406:1999 for particle sizes 4µl(c) / 8µl(c) / 14µl(c)

	Pressure < 140 bar < 2000 psi	Media β _w (c) = 1000 (β _w x = 200)	Pressure 212 bar 3000 psi	Media β _w (c) = 1000 (β _w x = 200)	Pressure > 212 bar > 3000 psi	Media β _w (c) = 1000 (β _w x = 200)
Pumps						
Fixed Gear	20/18/15	22µl(c) (25 µ)	19/17/15	12µl(c) (12 µ)	-	-
Fixed Piston	19/17/14	12µl(c) (12 µ)	18/16/13	12µl(c) (12 µ)	17/15/12	7µl(c) (6 µ)
Fixed Vane	20/18/15	22µl(c) (25 µ)	19/17/14	12µl(c) (12 µ)	18/16/13	12µl(c) (12 µ)
Variable Piston	18/16/13	7µl(c) (6 µ)	17/15/13	5µl(c) (3 µ)	16/14/12	7µl(c) (6 µ)
Variable Vane	18/16/13	7µl(c) (6 µ)	17/15/12	5µl(c) (3 µ)	-	-
Valves						
Cartridge	18/16/13	12µl(c) (12 µ)	17/15/12	7µl(c) (6 µ)	17/15/12	7µl(c) (6 µ)
Check Valve	20/18/15	22µl(c) (25 µ)	20/18/15	22µl(c) (25 µ)	19/17/14	12µl(c) (12 µ)
Directional (solenoid)	20/18/15	22µl(c) (25 µ)	19/17/14	12µl(c) (12 µ)	18/16/13	12µl(c) (12 µ)
Flow Control	19/17/14	12µl(c) (12 µ)	18/16/13	12µl(c) (12 µ)	18/16/13	12µl(c) (12 µ)
Pressure Control (modulating)	19/17/14	12µl(c) (12 µ)	18/16/13	12µl(c) (12 µ)	17/15/12	7µl(c) (6 µ)
Proportional Cartridge Valve	17/15/12	7µl(c) (6 µ)	17/15/12	7µl(c) (6 µ)	16/14/11	5µl(c) (3 µ)
Proportional Directional	17/15/12	7µl(c) (6 µ)	17/15/12	7µl(c) (6 µ)	16/14/11	5µl(c) (3 µ)
Proportional Flow Control	17/15/12	7µl(c) (6 µ)	17/15/12	7µl(c) (6 µ)	16/14/11	5µl(c) (3 µ)
Proportional Pressure Control	17/15/12	7µl(c) (6 µ)	17/15/12	7µl(c) (6 µ)	16/14/11	5µl(c) (3 µ)
Servo Valve	16/14/11	7µl(c) (6 µ)	16/14/11	5µl(c) (3 µ)	15/13/10	5µl(c) (3 µ)
Bearings						
Ball Bearing	15/13/10	5µl(c) (3 µ)	-	-	-	-
Gearbox (Industrial)	17/16/13	12µl(c) (12 µ)	-	-	-	-
Journal Bearing (high speed)	17/15/12	7µl(c) (6 µ)	-	-	-	-
Journal Bearing (low speed)	17/15/12	7µl(c) (6 µ)	-	-	-	-
Roller Bearing	16/14/11	7µl(c) (6 µ)	-	-	-	-
Actuators						
Cylinders	17/15/12	7µl(c) (6 µ)	16/14/11	5µl(c) (3 µ)	15/13/10	5µl(c) (3 µ)
Vane Motors	20/18/15	22µl(c) (25 µ)	19/17/14	12µl(c) (12 µ)	18/16/13	12µl(c) (12 µ)
Axial Piston Motors	19/17/14	12µl(c) (12 µ)	18/16/13	12µl(c) (12 µ)	17/15/12	7µl(c) (6 µ)
Gear Motors	20/18/14	22µl(c) (25 µ)	19/17/13	12µl(c) (12 µ)	18/16/13	12µl(c) (12 µ)
Radial Piston Motors	20/18/15	22µl(c) (25 µ)	19/17/14	12µl(c) (12 µ)	18/16/13	12µl(c) (12 µ)
Test Stands, Hydrostatic						
Test Stands	15/13/10	5µl(c) (3 µ)	15/13/10	5µl(c) (3 µ)	15/13/10	5µl(c) (3 µ)
Hydrostatic Transmissions	17/15/13	7µl(c) (6 µ)	16/14/11	5µl(c) (3 µ)	16/14/11	5µl(c) (3 µ)

*Depending upon system volume and severity of operating conditions a combination of filters with varying degrees of filtration efficiency might be required (i.e. pressure, return, and off-line filters) to achieve and maintain the desired fluid cleanliness.

Example		ISO Code	Comments
Operating Pressure	156 bar, 2200 psi		
Most Sensitive Component	Directional Solenoid	19/17/14	recommended baseline ISO Code
Fluid Type	Water Glycol	18/16/13	Adjust down one class
Operating Conditions	Remote location, repair difficult, High Ingression rate	17/15/12	Adjust down one class, combination of critical nature, severe conditions



Torque-Tension Relationship for ASTM A574 Socket Head Cap Screws

Nominal Dia (in.)	Unified Coarse Thread Series						Fine Thread Series					
	Threads per inch	Tensile Stress Area (sq. in.)	Clamp Load (lbs)	Tightening Torque		Clamp Load (lbs)	Tightening Torque		Clamp Load (lbs)	Tightening Torque		
				K = 0.10 (ft-lbs)	K = 0.15 (ft-lbs)		K = 0.10 (ft-lbs)	K = 0.15 (ft-lbs)		K = 0.10 (ft-lbs)	K = 0.15 (ft-lbs)	
1/4	20	0.5818	3341	19	11	14	12	13	15	16	18	
5/16	18	0.6534	4003	22	23	29	24	27	32	34	42	
3/8	16	0.6778	4136	38	41	51	43	46	58	61	75	
7/16	14	0.6953	4152	51	50	61	58	73	81	81	100	
1/2	13	0.7119	4189	63	60	74	70	88	97	97	120	
5/8	11	0.7269	4263	79	74	90	84	105	112	112	140	
3/4	9	0.7345	4365	97	90	108	100	125	132	132	165	
7/8	8	0.7417	4470	117	108	128	118	145	152	152	190	
1	7	0.7483	4582	139	128	150	138	168	175	175	215	
1 1/8	7	0.7541	4701	163	150	174	160	192	200	200	245	
1 1/4	6	0.7591	4826	189	174	200	185	220	230	230	280	
1 3/8	5	0.7633	4956	217	200	228	210	245	255	255	310	
1 1/2	5	0.7668	5091	247	228	258	235	275	285	285	345	
1 3/4	4	0.7697	5230	279	258	290	265	305	315	315	380	
2	4	0.7722	5374	313	290	324	300	340	350	350	420	

Clamp load calculated as 70% of the proof load for socket head cap screws as specified in ASTM A574.

Torque values calculated from formula: $T = KDF$, where

$K = 0.10$ for "lubricated" conditions, $K = 0.15$ "as-received" and $K = 0.20$ for "dry" conditions

$D =$ Nominal Diameter

$F =$ Clamp Load

Caution: All material included in this chart is advisory only, and its use by anyone is voluntary. In developing this information, Fastenal has made a determined effort to present its contents accurately. Extreme caution should be used when using a formula for torque/tension relationships. Torque is only an indirect indication of tension. Under/over tightening of fasteners can result in costly equipment failure or personal injury.

engineer@fastenal.com

Page Left Intentionally Blank

All information given in this Manual is current and valid per the information available at the time of publication. (Please check the updated revision date at the bottom of each page.)

American Piledriving Equipment (APE) reserves the right to implement changes without prior notice.

Please visit www.apevibro.com for the most recent version of this publication.

AMERICAN PILEDRIVING EQUIPMENT, INC.

7032 S. 196th Street

Kent, Washington 98032

Office: 253-872-0141

Toll Free: 800-248-8498

Fax: 253-872-8710